



Lasting Connections

WU 2000

USER MANUAL





91.09.048
01/05/2025
Rev. C

ENGLISH.....	6
ITALIANO.....	17
DEUTSCH.....	29
FRANÇAIS.....	41
ESPAÑOL.....	53
PORTUGUÊS.....	65
NEDERLANDS.....	77
SVENSKA.....	89
DANSK.....	101
NORSK.....	113
SUOMI.....	125
ΕΛΛΗΝΙΚΑ.....	137

EN

IT

DE

FR

ES

PT

NL

SV

DA

NO

FI

EL

UKCA - DECLARATION OF CONFORMITY

The builder
voestalpine Böhler Welding Arc Technology S.r.l.
Via Palladio, 19 - 35019 Onara di Tombolo (PD) - ITALY
Tel. +39 049 9413/111 - Fax +39 049 9413/311 - www.voestalpine.com/welding

declares under its sole responsibility that the following product:

WU 2000 **71.03.076**

is in conformity with the relevant UK Statutory Instruments (and their amendments):

2016 No. 1091 Electrical Equipment (Safety) Regulations 2016

2016 No. 1101 Electromagnetic Compatibility Regulations 2016

2012 No. 3032 The Restriction of the Use of Certain Hazardous Substances in Electrical and Electronic Equipment Regulations 2012

References to the relevant designated standards used or references to the other technical specifications in relation to which conformity is declared:

EN IEC 60974-2:2019 **LIQUID COOLING SYSTEMS**

EN 60974-10/A1:2015 **ELECTROMAGNETIC COMPATIBILITY REQUIREMENTS**

The documentation certifying compliance with the directives will be kept available for inspection at the aforementioned manufacturer.

Any operation or modification that has not been previously authorized by voestalpine Böhler Welding Arc Technology S.r.l. will invalidate this certificate.

Onara di Tombolo, 01/05/2025

voestalpine Böhler Welding Arc Technology S.r.l.



Mirco Frasson **Ivo Bonello**

Managing Directors

EU DECLARATION OF CONFORMITY

The builder
voestalpine Böhler Welding Arc Technology S.r.l.
Via Palladio, 19 - 35019 Onara di Tombolo (PD) - ITALY
Tel. +39 049 9413/111 - Fax +39 049 9413/311 - www.voestalpine.com/welding

declares under its sole responsibility that the following product:

WU 2000 **71.03.076**

conforms to the EU directives:

2014/35/EU **LOW VOLTAGE DIRECTIVE**

2014/30/EU **EMC DIRECTIVE**

2011/65/EU **RoHS DIRECTIVE**

and that following harmonized standards have been duly applied:

EN IEC 60974-2:2019

LIQUID COOLING SYSTEMS

EN 60974-10/A1:2015

ELECTROMAGNETIC COMPATIBILITY REQUIREMENTS

The documentation certifying compliance with the directives will be kept available for inspection at the aforementioned manufacturer.

Any operation or modification that has not been previously authorized by voestalpine Böhler Welding Arc Technology S.r.l. will invalidate this certificate.

Onara di Tombolo, 01/05/2025

voestalpine Böhler Welding Arc Technology S.r.l.

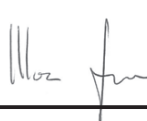

Mirco Frasson

Ivo Bonello

Managing Directors

INDEX

1. WARNING.....	8
1.1 Work environment.....	8
1.2 User's and other persons' protection.....	8
1.3 Protection from electrical shock.....	9
1.4 Electromagnetic fields and interferences.....	9
1.5 IP Protection rating.....	9
1.6 Cooling liquid.....	9
2. INSTALLATION.....	10
2.1 Lifting, transport & unloading.....	10
2.2 Positioning of the equipment.....	10
2.3 Connection.....	10
2.4 Installation.....	10
3. SYSTEM PRESENTATION.....	12
3.1 Rear panel.....	12
3.2 Front control panel.....	13
4. MAINTENANCE.....	13
4.1 Carry out the following periodic checks on the power source.....	13
4.2 Responsibility.....	14
5. ALARM CODES.....	14
6. TROUBLESHOOTING.....	14
7. TECHNICAL SPECIFICATIONS.....	15
8. RATING PLATE.....	16
9. MEANING RATING PLATE.....	16
10. DIAGRAM.....	149
11. CONNECTORS.....	150
12. SPARE PARTS LIST.....	151

SYMBOLS



Warning



Prohibitions



Mandatory



General conditions

1. WARNING



Before performing any operation on the machine, make sure that you have thoroughly read and understood the contents of this booklet. Do not perform modifications or maintenance operations which are not prescribed. Do consult qualified personnel for any doubt or problem concerning the use of the machine, even if not described herein.

Do not perform modifications or maintenance operations which are not prescribed. The manufacturer cannot be held responsible for damages to persons or property caused by misuse or non-application of the contents of this booklet by the user.

The operating instructions must always be at hand wherever the device is being used. In addition to the operating instructions, attention must also be paid to any generally applicable and local regulations regarding accident prevention and environmental protection.

voestalpine Böhler Welding Arc Technology S.r.l. s.r.l. reserves the right to modify this booklet at any time without notice. All rights of translation and total or partial reproduction by any means whatsoever (including photocopy, film, and microfilm) are reserved and reproduction is prohibited without the explicit written consent of **voestalpine Böhler Welding Arc Technology S.r.l.**

The directions provided herewith are of vital importance and therefore necessary to ensure the warranties. The manufacturer accepts no liability in case of misuse or non-application of the directions by the users.



All persons involved in commissioning, operating, maintaining and servicing the device must:

- be suitably qualified
- read and follow these operating instructions carefully

Please consult qualified personnel if you have any doubts or difficulties in using the equipment.

1.1 Work environment



All equipment shall be used exclusively for the operations for which it was designed, in the ways and ranges stated on the rating plate and/or in this booklet, according to the national and international directives regarding safety. Other uses than the one expressly declared by the manufacturer shall be considered totally inappropriate and dangerous and in this case the manufacturer disclaims all responsibility.



This unit must be used for professional applications only, in industrial environments. The manufacturer will accept no responsibility for any damages caused by use in domestic environments.



The equipment must be used in environments with a temperature between -10°C and $+40^{\circ}\text{C}$ (between $+14^{\circ}\text{F}$ and $+104^{\circ}\text{F}$).

The equipment must be transported and stored in environments with a temperature between -25°C and $+55^{\circ}\text{C}$ (between -13°F and 131°F).

The equipment must be used in environments free from dust, acid, gas or any other corrosive substances.

The equipment shall not be used in environments with a relative humidity higher than 50% at 40°C (104°F).

The equipment shall not be used in environments with a relative humidity higher than 90% at 20°C (68°F).

The system must not be used at an higher altitude than 2,000 metres (6,500 feet) above sea level.

1.2 User's and other persons' protection



Check that the torch is cold before working on or maintaining it.



Ensure the cooling unit is switched off before disconnecting the pipes of the cooling liquid. The hot liquid coming out of the pipes might cause burning or scorching.



Keep a first aid kit ready for use.
Do not underestimate any burning or injury.



Before leaving work, make the area safe, in order to avoid accidental damage to people or property.

1.3 Protection from electrical shock



Electric shocks can kill you.

- Avoid touching live parts both inside and outside the welding system while this is active (torches, guns, earth cables, electrodes, wires, rollers and spools are electrically connected to the welding circuit).
- Make sure that the welding system and the welder are electrically isolated by using dry bases and floors that are adequately isolated from earth.

1.4 Electromagnetic fields and interferences

1.4.1 EMC classification in accordance with: EN 60974-10/A1:2015.

Class B

Class B equipment complies with electromagnetic compatibility requirements in industrial and residential environments, including residential locations where the electrical power is provided by the public low-voltage supply system.

Class A

Class A equipment is not intended for use in residential locations where the electrical power is provided by the public low-voltage supply system. There may be potential difficulties in ensuring electromagnetic compatibility of class A equipment in those locations, due to conducted as well as radiated disturbances.

For more informations, check the chapter: RATING PLATE or TECHNICAL SPECIFICATIONS.

1.4.2 Installation, use and area examination

This equipment is manufactured in compliance with the requirements of the harmonized standard EN 60974-10/A1:2015 and is identified as "CLASS A" equipment. This unit must be used for professional applications only, in industrial environments. The manufacturer will accept no responsibility for any damages caused by use in domestic environments.



The user must be an expert in the activity and as such is responsible for installation and use of the equipment according to the manufacturer's instructions. If any electromagnetic interference is noticed, the user must solve the problem, if necessary with the manufacturer's technical assistance.



In any case electromagnetic interference problems must be reduced until they are not a nuisance any longer.



Before installing this equipment, the user must evaluate what electromagnetic problems it might cause in the surrounding area, with specific regard to the health of persons nearby, pace-maker and hearing aid users, for example.

1.4.3 Shielding

The selective shielding of other cables and equipment present in the surrounding area may reduce the problems due to electromagnetic interference.

The shielding of the entire welding equipment can be taken in considered for special applications.

1.5 IP Protection rating

IP

IP23S

- Enclosure protected against access to dangerous parts by fingers and against ingress of solid bodies objects with diameter equal or greater than 12.5 mm.
- Enclosure protected against rain at an angle of 60°.
- Enclosure protected against harmful effects due to the ingress of water when the moving parts of the equipment are not operating.

1.6 Cooling liquid

1.6.1 Personal protection



Product harmful if swallowed.
Can cause irritation to eyes, mucous membranes and skin.



Use rubber gloves to prevent contact.



Use safety goggles to prevent accidental splashes.



Wear ordinary work clothes to prevent contact with the skin.

1.6.2 Disposal



Do not dispose of electrical equipment together with normal waste!

In conformity to European Directive 2012/19/EU on Waste Electrical and Electronic Equipment and its implementation according to national law, electrical equipment must be collected separately and disposed of through an authorised recovery and disposal centre at the end of its life cycle. The owner of the equipment is required to identify authorised collection centres on the basis of the information provided by Local Authorities. By applying this European Directive you will improve the environment and human health!



Any leaks or remains of product, after it has been used, must be treated in a suitable purification plant or recycled if possible. Do not discharge the used product into watercourses, ditches or drainage systems. The diluted fluid should not be discharged into the sewers unless permitted by the local regulations.

2. INSTALLATION

2.1 Lifting, transport & unloading

- The equipment is not equipped with specific lifting elements.



Do not underestimate the weight of the equipment: see technical specifications.

Do not move or position the suspended load above persons or things.

Do not drop or apply undue pressure on the equipment.

2.2 Positioning of the equipment



Keep to the following rules:

- Provide easy access to the equipment controls and connections.
- Do not position the equipment in very small spaces.
- Do not place the equipment on surfaces with inclination exceeding 10° from to the horizontal plane.
- Position the equipment in a dry, clean and suitably ventilated place.
- Protect the equipment against pouring rain and sun.
- » Consult the "Prevention when using gas cylinders" section.

2.3 Connection



Disconnect the power supply before every operation!

2.4 Installation

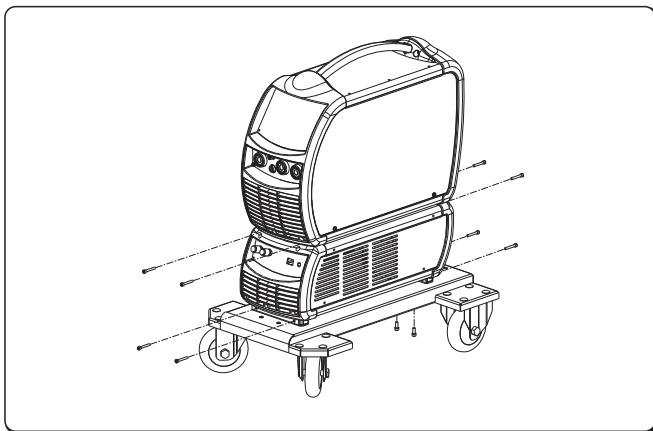

- ▶ Put the WU on the GT and block it with the 4 screws.
- ▶ Position the power source above the cooling unit and secure it by means of the screws.

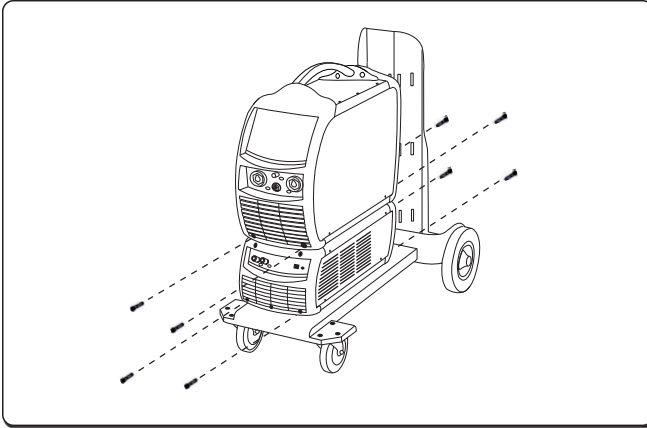

- ▶ Put the WU on the GT and block it with the 4 screws.
- ▶ Position the power source above the cooling unit and secure it by means of the screws.

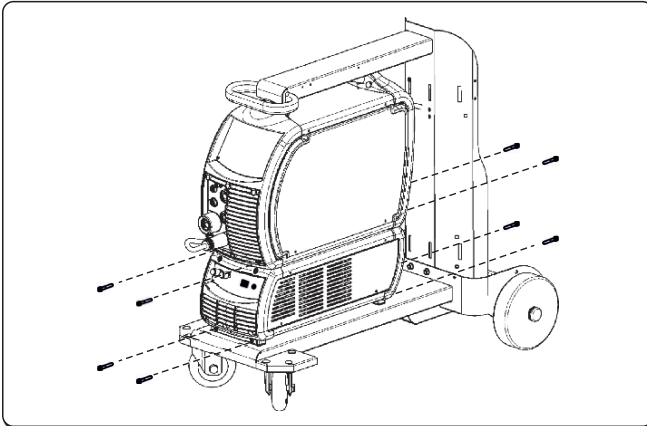

- ▶ Put the WU on the GT and block it with the 4 screws.
- ▶ Position the power source above the cooling unit and secure it by means of the screws.

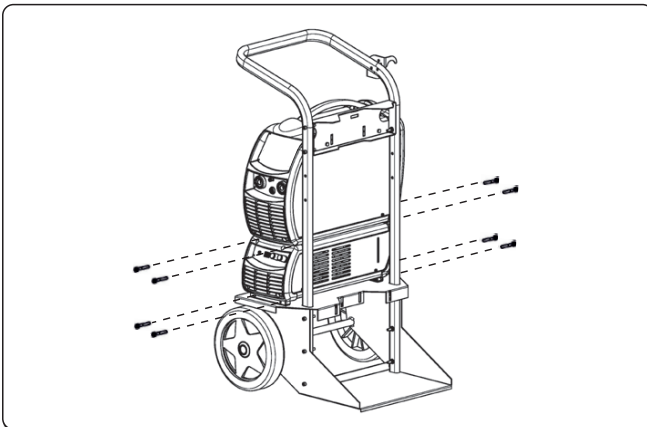

- ▶ Put the WU on the GT and block it with the 4 screws.
- ▶ Position the power source above the cooling unit and secure it by means of the screws.



Perform the following operations before starting the unit:

- ▶ Remove the refill neck cap.
- ▶ Remove the sealing cap from the refill neck, levering by means of a tool on the edge of the cap.
- ▶ Fill the tank with cooling liquid if necessary.
- ▶ Keep apart the sealing cap for future transport of the unit.



In order to avoid any damage the cooling unit, always fit the by-pass pipe when the torch is not connected to the cooling liquid inlet/outlet terminals.



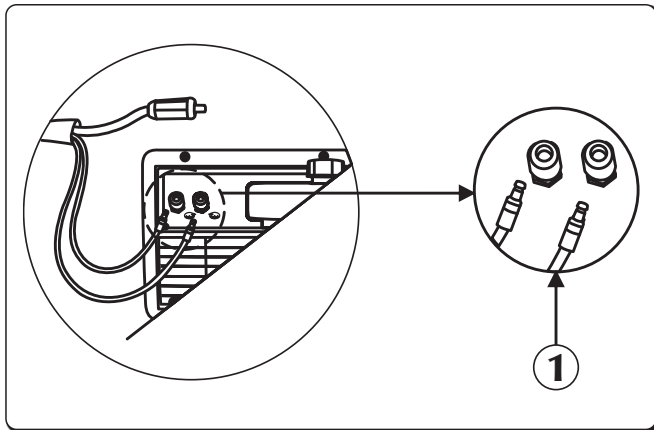

Filling or topping up of the tank must be performed with cooling liquid, code 18.91.008.

2.4.1 Rear panel connection





① Cooling liquid inlet/outlet

- ▶ Connect the water pipe (blue coloured) to the outlet quick connector (blue coloured - symbol ) of the cooling unit.
- ▶ Connect the water pipe (red coloured) to the inlet quick connector (red coloured - symbol ) of the cooling unit.

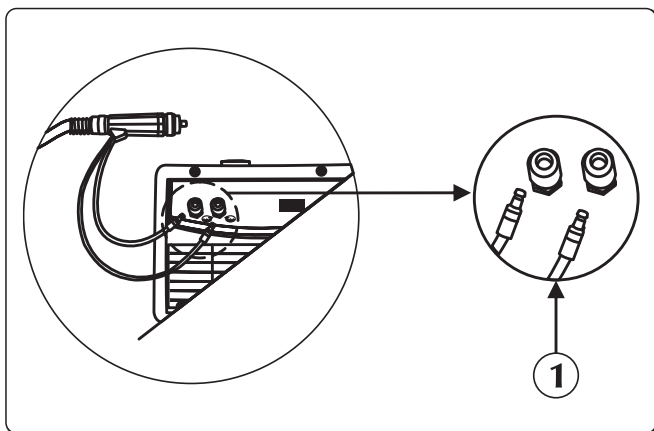
2.4.2 Front panel connection



① Cooling liquid inlet/outlet

- ▶ Connect the water pipe (blue coloured) of the torch to the outlet quick connector (blue coloured - symbol ) of the cooling unit.
- ▶ Connect the water pipe (red coloured) of the torch to the inlet quick connector (red coloured - symbol ) of the cooling unit.

3. SYSTEM PRESENTATION

3.1 Rear panel

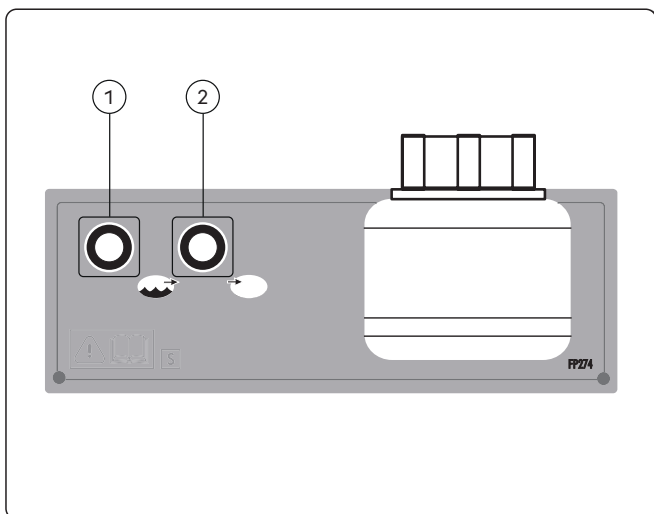

① Cooling liquid outlet connector





To supply low temperature liquid into the torch cooling circuit.

② Cooling liquid inlet connector

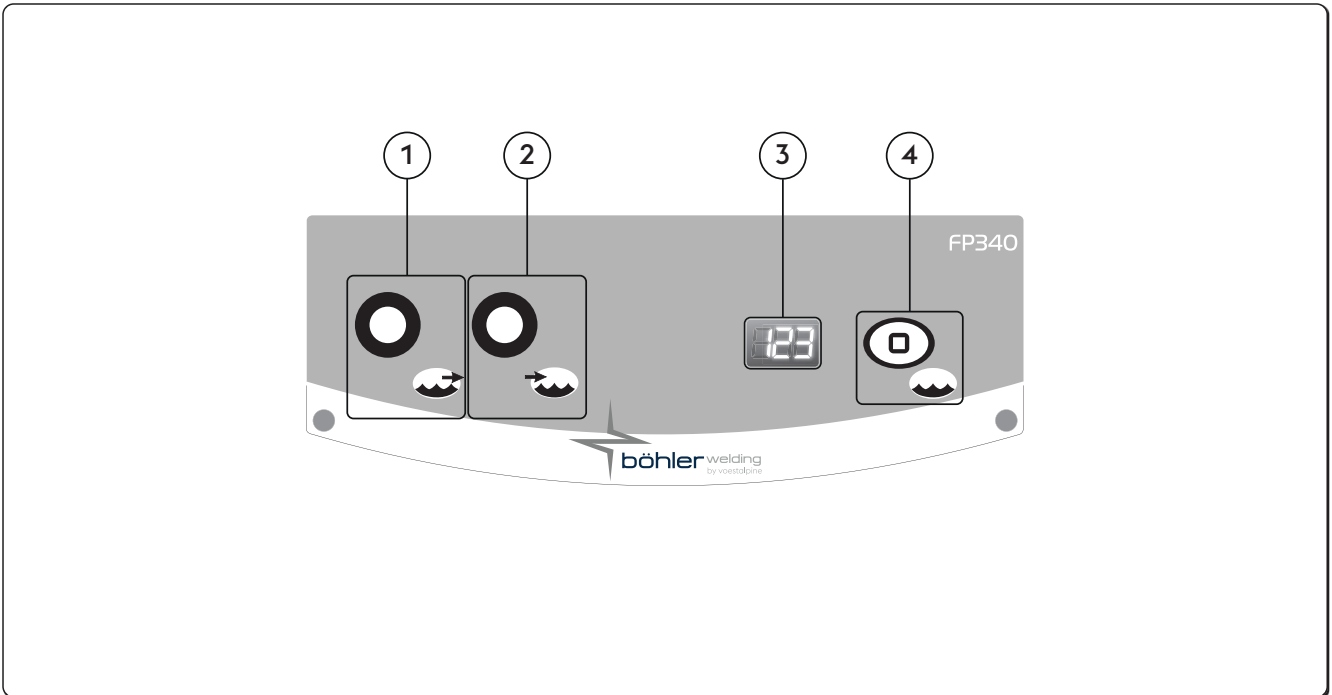

To return the liquid that has been heated by the torch into the cooling circuit inside the WU.

3.2 Front control panel



- 
1 Cooling liquid outlet connector
 To supply low temperature liquid into the torch cooling circuit.
- 
2 Cooling liquid inlet connector
 To return the liquid that has been heated by the torch into the cooling circuit inside the WU.
- 
3 7-segment display
 Allows display of the general parameters of the WU during start-up, its correct operation and the internal temperature of the cooling fluid.
 -- Cooling unit disabled.
- 
4 Cooling unit test

4. MAINTENANCE

- 
 Routine maintenance must be carried out on the system according to the manufacturer's instructions. When the equipment is working, all the access and operating doors and covers must be closed and locked. The system must not be modified in any way. Prevent conductive dust from accumulating near the louvers and over them.
- 
 Any maintenance operation must be performed by qualified personnel only. The repair or replacement of any parts in the system by unauthorised personnel will invalidate the product warranty. The repair or replacement of any parts in the system must be carried out only by qualified personnel.
- 
 Disconnect the power supply before every operation!

4.1 Carry out the following periodic checks on the power source

- 
 Periodically check the cooling liquid level in the tank. If the tank is completely empty and/or there is air in the cooling circuit, this may cause malfunctions of the pump.
- Clean the power source inside by means of low-pressure compressed air and soft bristle brushes.
 - Check the electrical connections and all the connection cables.
 - Check the condition of the electric pump.
 - Check the state of the hose connections.

Every six months, change the cooling liquid and wash out the hoses and tank with water. Change the liquid in cases, where it should boil, since it would lose its protective properties.



Filling or topping up of the tank with cooling liquid must be performed with the power source and WU assembled and positioned on a horizontal surface.



Filling or topping up of the tank must be performed with cooling liquid, code 18.91.008. The equipment must not be used without cooling liquid.



Do not use conductive cooling liquids.



Clean the power source inside by means of low-pressure compressed air and soft bristle brushes. Check the electric connections and all the connection cables.

4.2 Responsibility



Failure to carry out the above maintenance will invalidate all warranties and exempt the manufacturer from any liability. The manufacturer disclaims any responsibility if the user fails to follow these instructions. For any doubts and/or problems do not hesitate to contact your nearest customer service centre.

5. ALARM CODES



ALARM















Activation of an alarm or the passing of any critical limit causes a visual signal to appear on the control panel and the immediate shut-down of welding operations.



CAUTION

Exceeding a guard limit causes a visual signal on the control panel but allows the welding operations to continue.

All the alarms and all the guard limits relating to the system are listed below.

 E43	Coolant shortage		 E71	Coolant overtemperature	
 E76	Liquid coolant flow level exceeded		 E77	Coolant temperature level exceeded	
 E81	Overcurrent (WU pump)		 E82	Communication error (WU)	
 E83	Pump blocked				

6. TROUBLESHOOTING

No liquid flow in circuit

Cause

- » No liquid in the tank.
- » Air in cooling circuit.

Solution

- » Refill.
- » Connect the by-pass to the outlet connection (blue colour) and bleed the hydraulic circuit allowing the cooling fluid to emerge for a few seconds.

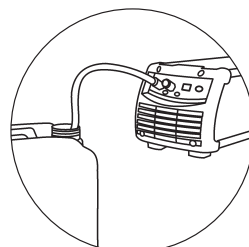

» Cooling circuit blocked or broken.	<ul style="list-style-type: none"> » Check the state of the connections (inside the unit) of the hydraulic circuit. » Check the state of the torch's hydraulic circuit. » Check the condition of the coolant circuit in the cable bundle. » Contact the nearest service centre to have the system repaired.
» Presence of the cooling unit alarm.	<ul style="list-style-type: none"> » Reset the alarm. » Connect a torch or the by-pass in the operating modes requiring the cooling unit to be active. » Check the state of the connections (inside the unit) of the hydraulic circuit. » Check the state of the torch's hydraulic circuit. » Contact the nearest service centre to have the system repaired.
» Faulty pump.	<ul style="list-style-type: none"> » Replace the faulty component. » Contact the nearest service centre to have the system repaired.

Insufficient cooling capacity

Cause	Solution
» Faulty fan.	<ul style="list-style-type: none"> » Replace the faulty component. » Contact the nearest service centre to have the system repaired.
» Faulty pump.	<ul style="list-style-type: none"> » Replace the faulty component. » Contact the nearest service centre to have the system repaired.

7. TECHNICAL SPECIFICATIONS

Electrical characteristics		U.M.
Power supply voltage U1	360	Vdc
Max. input current I1max	0.4	A
Cooling power (25°C)	1000	W
Physical characteristics		U.M.
IP Protection rating	IP23S	
Dimensions (lxdxh)	660x240x220	mm
Weight	12.0	Kg
Type of exchanger	H ₂ O - Air	
Nominal flow rate (QV)	2.3	l/min
Maximum pump flow rate (Qvmax)	4.6	l/min
Pump total head (Hmax)	35	m
Pump type	Centrifugal	
Maximum speed	3300	RPM
Tank capacity	3.0	l
Manufacturing Standards	EN IEC 60974-2:2019 EN 60974-10/A1:2015	

8. RATING PLATE

VOESTALPINE BÖHLER WELDING ARC TECHNOLOGY S.R.L. Via Palladio, 19 - ONARA (PADOVA) - ITALY						
WU 2000		N°				
<table border="1"> <tr> <td>EN</td> <td>60974-2:2019</td> </tr> <tr> <td>IEC</td> <td>60974-10/A1:2015 Class A</td> </tr> </table>			EN	60974-2:2019	IEC	60974-10/A1:2015 Class A
EN	60974-2:2019					
IEC	60974-10/A1:2015 Class A					
Energy input						
 1	U₁ 350V	I_{1max} 0.35A				
	IP 23 S					
Liquid cooling system						
	P_{11/min} 1.0kW	P_{max} 0.35MPa (3.5bar)				
MADE IN ITALY						

9. MEANING RATING PLATE

1		2		
3		4		
5				
6	7		8	
	9			
10	11		12	
			MADE IN ITALY	

- 1 Trademark
- 2 Name and address of manufacturer
- 3 Machine model
- 4 Serial no.
X**XX**XXXXXXXXXX Year of manufacture
- 5 Reference to construction standards
- 6 Power supply symbol
- 7 Rated power supply voltage
- 8 Maximum rated power supply current
- 9 Protection rating
- 10 Cooling system symbol
- 11 Cooling power
- 12 Maximum pressure

CE EU declaration of conformity
 EAC EAC declaration of conformity
 UKCA UKCA declaration of conformity

DICHIARAZIONE DI CONFORMITÀ EU

Il costruttore
voestalpine Böhler Welding Arc Technology S.r.l.
Via Palladio, 19 - 35019 Onara di Tombolo (PD) - ITALY
Tel. +39 049 9413/111 - Fax +39 049 9413/311 - www.voestalpine.com/welding

dichiara sotto la propria esclusiva responsabilità che il seguente prodotto:

WU 2000 **71.03.076**

è conforme alle direttive EU:

2014/35/EU **LOW VOLTAGE DIRECTIVE**

2014/30/EU **EMC DIRECTIVE**

2011/65/EU **RoHS DIRECTIVE**

e che sono state applicate le norme:

EN IEC 60974-2:2019 **LIQUID COOLING SYSTEMS**

EN 60974-10/A1:2015 **ELECTROMAGNETIC COMPATIBILITY REQUIREMENTS**

La documentazione attestante la conformità alle direttive sarà tenuta a disposizione per ispezioni presso il sopracitato costruttore.

Ogni intervento o modifica non autorizzati dalla voestalpine Böhler Welding Arc Technology S.r.l. faranno decadere la validità di questa dichiarazione.

Onara di Tombolo, 01/05/2025

voestalpine Böhler Welding Arc Technology S.r.l.



Mirco Frasson **Ivo Bonello**

Managing Directors

INDICE

1. AVVERTENZE	19
1.1 Ambiente di utilizzo	19
1.2 Protezione personale e di terzi	19
1.3 Protezione da shock elettrico.....	19
1.4 Campi elettromagnetici ed interferenze.....	20
1.5 Grado di protezione IP.....	20
1.6 Liquido di raffreddamento	20
2. INSTALLAZIONE	21
2.1 Modalità di sollevamento, trasporto e scarico.....	21
2.2 Posizionamento dell'impianto	21
2.3 Allacciamento	21
2.4 Messa in servizio	21
3. PRESENTAZIONE DELL'IMPIANTO	23
3.1 Pannello posteriore.....	23
3.2 Pannello comandi frontale	24
4. MANUTENZIONE	24
4.1 Controlli periodici	24
4.2 Responsabilità.....	25
5. CODIFICA ALLARMI	25
6. DIAGNOSTICA E SOLUZIONI	25
7. CARATTERISTICHE TECNICHE	26
8. TARGA DATI	27
9. SIGNIFICATO TARGA DATI	27
10. SCHEMA	149
11. CONNETTORI	150
12. LISTA RICAMBI	151

SIMBOLOGIA

-  Avvertenze
-  Divieti
-  Obblighi
-  Indicazioni generali

1. AVVERTENZE



Prima di iniziare qualsiasi operazione siatesicuridiaverbenlettoe compresoquestomanuale. Non apportate modifiche e non eseguite manutenzioni non descritte. Il produttore non si fa carico di danni a persone o cose, occorsi per incuria nella lettura o nella messa in pratica di quanto scritto in questo manuale. Conservare sempre le istruzioni per l'uso sul luogo d'impiego dell'apparecchio. Oltre alle istruzioni per l'uso, attenersi alle norme generali e ai regolamenti locali vigenti in materia di prevenzione degli incidenti e tutela dell'ambiente.

La voestalpine Böhler Welding Arc Technology S.r.l. si riserva il diritto di apportare modifiche in qualsiasi momento e senza alcun preavviso.

I diritti di traduzione, di riproduzione e di adattamento, totale o parziale e con qualsiasi mezzo (compresi le copie fotostatiche, i film ed i microfilm) sono riservati e vietati senza l'autorizzazione scritta della voestalpine Böhler Welding Arc Technology S.r.l.

Quanto esposto è di vitale importanza e pertanto necessario affinché le garanzie possano operare.

Nel caso l'operatore non si attenesse a quanto descritto, il costruttore declina ogni responsabilità.



Tutte le persone addette alla messa in funzione, all'utilizzo, alla manutenzione e alla riparazione dell'apparecchio devono

- essere in possesso di apposita qualifica
- leggere integralmente e osservare scrupolosamente le presenti istruzioni per l'uso.

Per ogni dubbio o problema circa l'utilizzo dell'impianto, anche se qui non descritto, consultare personale qualificato.

1.1 Ambiente di utilizzo



Ogni impianto deve essere utilizzato esclusivamente per le operazioni per cui è stato progettato, nei modi e nei campi previsti in targa dati e/o in questo manuale, secondo le direttive nazionali e internazionali relative alla sicurezza. Un utilizzo diverso da quello espressamente dichiarato dal costruttore è da considerarsi totalmente inappropriato e pericoloso e in tal caso il costruttore declina ogni responsabilità.



Questo apparecchio deve essere usato solo a scopo professionale in un ambiente industriale. Il costruttore non risponderà di danni provocati dall'uso dell'impianto in ambienti domestici.



L'impianto deve essere utilizzato in ambienti con temperatura compresa tra i -10°C e i +40°C (tra i +14°F e i +104°F). L'impianto deve essere trasportato e immagazzinato in ambienti con temperatura compresa tra i -25°C e i +55°C (tra i -13°F e i 131°F).

L'impianto deve essere utilizzato in ambienti privi di polvere, acidi, gas o altre sostanze corrosive.

L'impianto deve essere utilizzato in ambienti con umidità relativa non superiore al 50% a 40°C (104°F).

L'impianto deve essere utilizzato in ambienti con umidità relativa non superiore al 90% a 20°C (68°F).

L'impianto deve essere utilizzato ad una altitudine massima sul livello del mare di 2000m (6500 piedi).

1.2 Protezione personale e di terzi



Assicurarsi che la torcia si sia raffreddata prima di eseguire lavorazioni o manutenzioni.



Assicurarsi che il gruppo di raffreddamento sia spento prima di sconnettere i tubi di mandata e ritorno del liquido refrigerante. Il liquido caldo in uscita potrebbe causare gravi ustioni o scottature.



Provvedere ad un'attrezzatura di pronto soccorso.
Non sottovalutare scottature o ferite.



Prima di lasciare il posto di lavoro, porre in sicurezza l'area di competenza in modo da impedire danni accidentali a cose o persone.

1.3 Protezione da shock elettrico



Uno shock da scarica elettrica può essere mortale.

- Evitare di toccare parti normalmente in tensione interne o esterne all'impianto di saldatura mentre l'impianto stesso è alimentato (torce, pinze, cavi massa, elettrodi, fili, rulli e bobine sono elettricamente collegati al circuito di saldatura).
- Assicurare l'isolamento elettrico dell'impianto e dell'operatore utilizzando piani e basamenti asciutti e sufficientemente isolati dal potenziale di terra e di massa.

1.4 Campi elettromagnetici ed interferenze

1.4.1 Classificazione EMC in accordo con la norma: EN 60974-10/A1:2015.

Classe B

L'apparecchiatura di Classe B è conforme con i requisiti di compatibilità elettromagnetica in ambienti industriali e residenziali, incluse aree residenziali dove l'energia elettrica è fornita da un sistema pubblico a bassa tensione.

Classe A

L'apparecchiatura di Classe A non è intesa per l'uso in aree residenziali dove l'energia elettrica è fornita da un sistema pubblico a bassa tensione. Può essere potenzialmente difficile assicurare la compatibilità elettromagnetica di apparecchiature di classe A in questi aree, a causa di disturbi irradiati e condotti.

Per maggiori informazioni consultare: TARGA DATI o CARATTERISTICHE TECNICHE.

1.4.2 Installazione, uso e valutazione dell'area

Questo apparecchio è costruito in conformità alle indicazioni contenute nella norma armonizzata: EN 60974-10/A1:2015 ed è identificato come di "CLASSE A". Questo apparecchio deve essere usato solo a scopo professionale in un ambiente industriale. Il costruttore non risponderà di danni provocati dall'uso dell'impianto in ambienti domestici.



L'utilizzatore deve essere un esperto del settore ed in quanto tale è responsabile dell'installazione e dell'uso dell'apparecchio secondo le indicazioni del costruttore. Qualora vengano rilevati dei disturbi elettromagnetici, spetta all'utilizzatore dell'apparecchio risolvere la situazione avvalendosi dell'assistenza tecnica del costruttore.



In tutti i casi i disturbi elettromagnetici devono essere ridotti fino al punto in cui non costituiscono più un fastidio.



Prima di installare questo apparecchio, l'utilizzatore deve valutare i potenziali problemi elettromagnetici che si potrebbero verificare nell'area circostante e in particolare la salute delle persone circostanti, per esempio: utilizzatori di pace-maker e di apparecchi acustici.

1.4.3 Schermatura

La schermatura selettiva di altri cavi e apparecchi presenti nell'area circostante può alleviare i problemi di interferenza. La schermatura dell'intero impianto di saldatura può essere presa in considerazione per applicazioni speciali.

1.5 Grado di protezione IP

IP

IP23S

- Involucro protetto contro l'accesso a parti pericolose con un dito e contro corpi solidi estranei di diametro maggiore o uguale a 12,5 mm.
- Involucro protetto contro pioggia a 60° sulla verticale.
- Involucro protetto dagli effetti dannosi dovuti all'ingresso d'acqua, quando le parti mobili dell'apparecchiatura non sono in moto.

1.6 Liquido di raffreddamento

1.6.1 Protezione personale



Prodotto nocivo per ingestione.
Può provocare irritazione agli occhi, alle mucose e all'epidermide.



Evitare il contatto utilizzando guanti in gomma.



Evitare schizzi accidentali utilizzando degli occhiali di sicurezza.



Evitare il contatto con la pelle con normali indumenti da lavoro.

1.6.2 Smaltimento



Non collocare l'apparecchiatura elettrica tra i normali rifiuti!
In osservanza alla Direttiva Europea 2012/19/EU sui Rifiuti di Apparecchiature Elettriche ed Elettroniche e alla sua implementazione in accordo con le leggi nazionali, le apparecchiature elettriche che hanno raggiunto la fine del ciclo di vita devono essere raccolte separatamente e inviate ad un centro di recupero e smaltimento. Il proprietario dell'apparecchiatura dovrà identificare i centri di raccolta autorizzati informandosi presso le Amministrazioni Locali. L'applicazione della Direttiva Europea permetterà di migliorare l'ambiente e la salute umana.



Le perdite o i residui del prodotto, dopo che lo stesso è stato utilizzato nel suo impiego tipico, devono essere trattati in un idoneo impianto di depurazione o se possibile, effettuare il riciclo del prodotto. Non è permesso scaricare il prodotto usato in corsi d'acqua, fossi o sistemi di drenaggio. Il fluido diluito non dovrebbe essere scaricato nelle fognature a meno che non sia permesso dalle normative locali.

2. INSTALLAZIONE

2.1 Modalità di sollevamento, trasporto e scarico

- L'impianto non è provvisto di elementi specifici per il sollevamento.



Non sottovalutare il peso dell'impianto, vedi caratteristiche tecniche.
Non far transitare o sostare il carico sospeso sopra a persone o cose.
Non lasciare cadere o appoggiare con forza l'impianto o la singola unità.

2.2 Posizionamento dell'impianto



Osservare le seguenti norme:

- Facile accesso ai comandi ed ai collegamenti.
- Non posizionare l'attrezzatura in ambienti angusti.
- Non posizionare mai l'impianto su di un piano con inclinazione maggiore di 10° dal piano orizzontale.
- Collocare l'impianto in un luogo asciutto, pulito e con ventilazione appropriata.
- Proteggere l'impianto contro la pioggia battente e contro il sole.
- » Consultare la sezione "Prevenzione nell'uso delle bombole di gas".

2.3 Allacciamento



Togliere l'alimentazione all'impianto prima di ogni intervento!

2.4 Messa in servizio

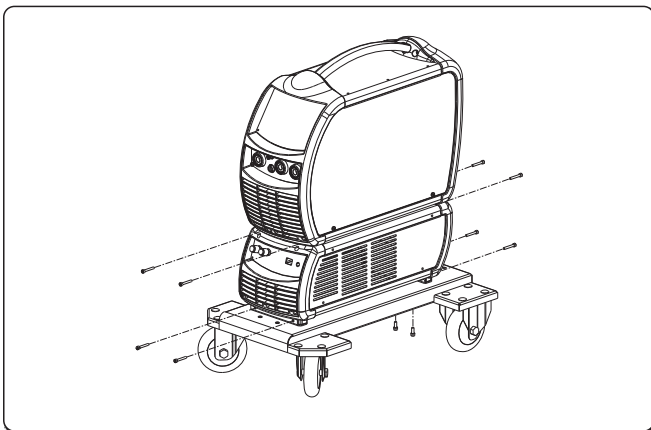

- ▶ Appoggiare il WU sopra il GT e fissarlo con le relative 4 viti.
- ▶ Posizionare il generatore sopra il gruppo di raffreddamento e fissare con le apposite viti.

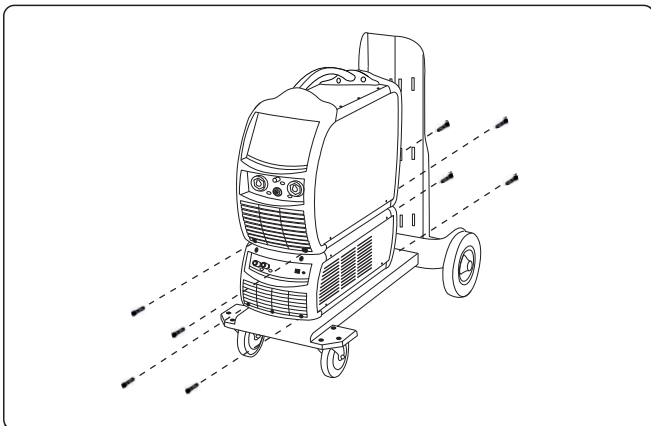

- ▶ Appoggiare il WU sopra il GT e fissarlo con le relative 4 viti.
- ▶ Posizionare il generatore sopra il gruppo di raffreddamento e fissare con le apposite viti.

IT

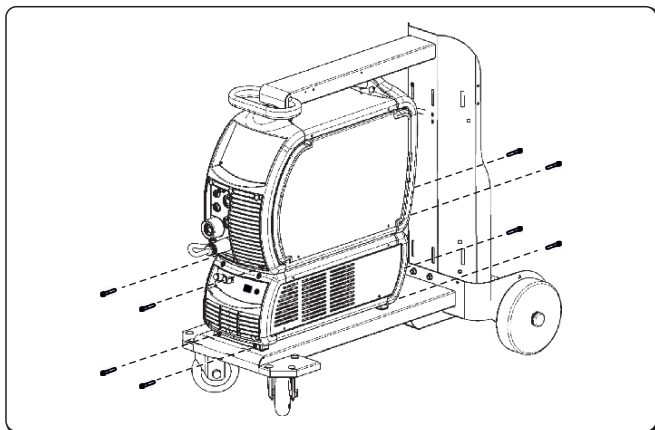

- ▶ Appoggiare il WU sopra il GT e fissarlo con le relative 4 viti.
- ▶ Posizionare il generatore sopra il gruppo di raffreddamento e fissare con le apposite viti.

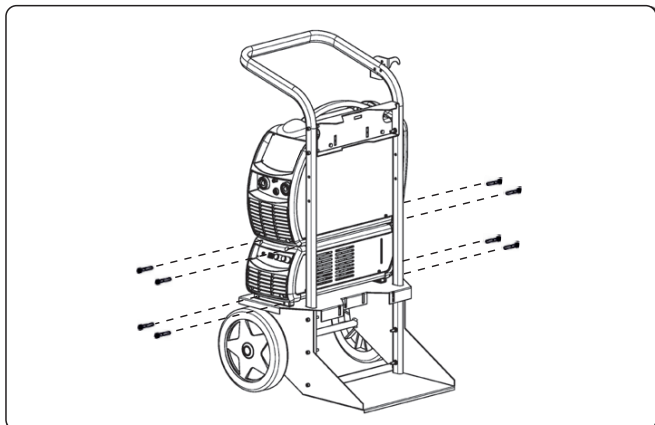

- ▶ Appoggiare il WU sopra il GT e fissarlo con le relative 4 viti.
- ▶ Posizionare il generatore sopra il gruppo di raffreddamento e fissare con le apposite viti.



Prima di mettere in funzione il gruppo stesso eseguire le seguenti operazioni:

- ▶ Togliere il tappo di chiusura del serbatoio.
- ▶ Togliere il tappo ermetico dal canale di imbrocco, facendo leva tramite un utensile sul bordo del tappo stesso.
- ▶ Aggiungere del liquido se necessario all'interno del serbatoio.
- ▶ Tenere il tappo ermetico per eventuali trasporti futuri del gruppo.



Per non danneggiare il gruppo di raffreddamento, montare sempre il tubo by-pass quando la torcia non è collegata ai terminali d'ingresso/uscita liquido refrigerante.



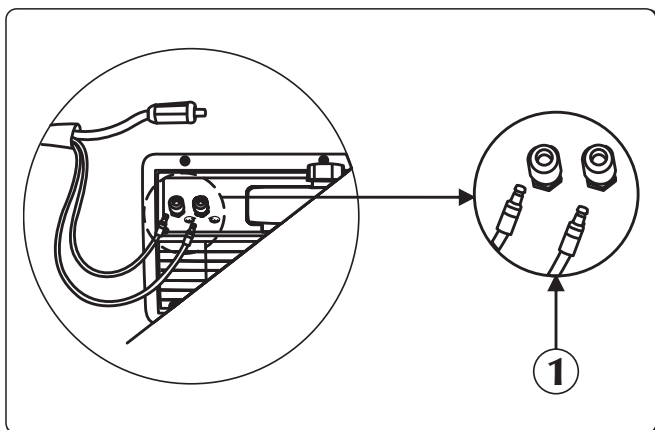

Il riempimento o rabbocco del serbatoio deve essere eseguito con liquido refrigerante cod. 18.91.008.

2.4.1 Collegamento pannello posteriore





① Ingresso/uscita liquido di raffreddamento

- ▶ Collegare il tubo di mandata liquido refrigerante del fascio cavi (colore blu) all'apposito raccordo/innesto  (colore blu).
- ▶ Collegare il tubo di ritorno liquido refrigerante del fascio cavi (colore rosso) all'apposito raccordo/innesto  (colore rosso).

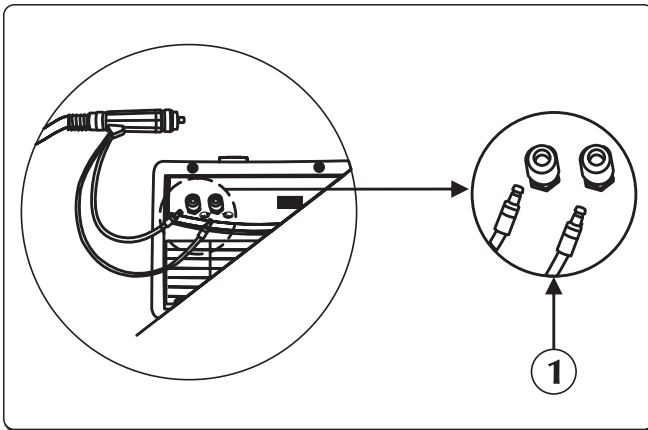
2.4.2 Collegamento pannello frontale



- ① Ingresso/uscita liquido di raffreddamento

- ▶ Collegare il tubo di mandata liquido refrigerante della torcia (colore blu) all'apposito raccordo/innesto  (colore blu).
- ▶ Collegare il tubo di ritorno liquido refrigerante della torcia (colore rosso) all'apposito raccordo/innesto  (colore rosso).

3. PRESENTAZIONE DELL'IMPIANTO

3.1 Pannello posteriore

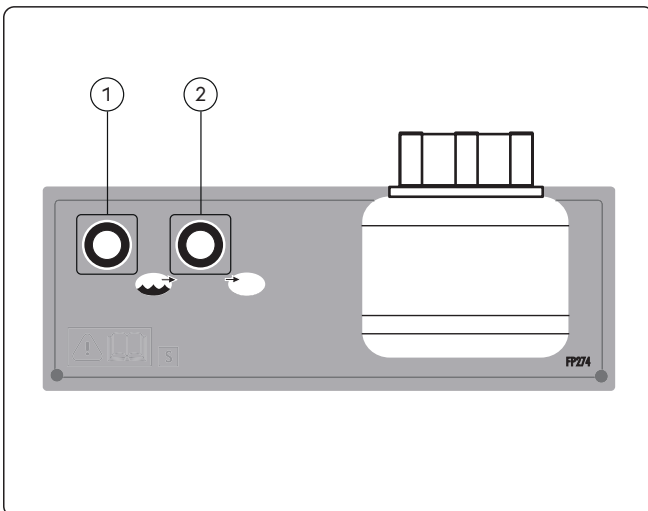

- ① **Raccordo/innesto uscita liquido refrigerante**
Permette di immettere liquido a bassa temperatura nel circuito di raffreddamento della torcia.
- ② **Raccordo/innesto ingresso liquido refrigerante**
Permette di immettere liquido, che ha subito il riscaldamento della torcia, nel circuito di raffreddamento interno al WU.

3.2 Pannello comandi frontale

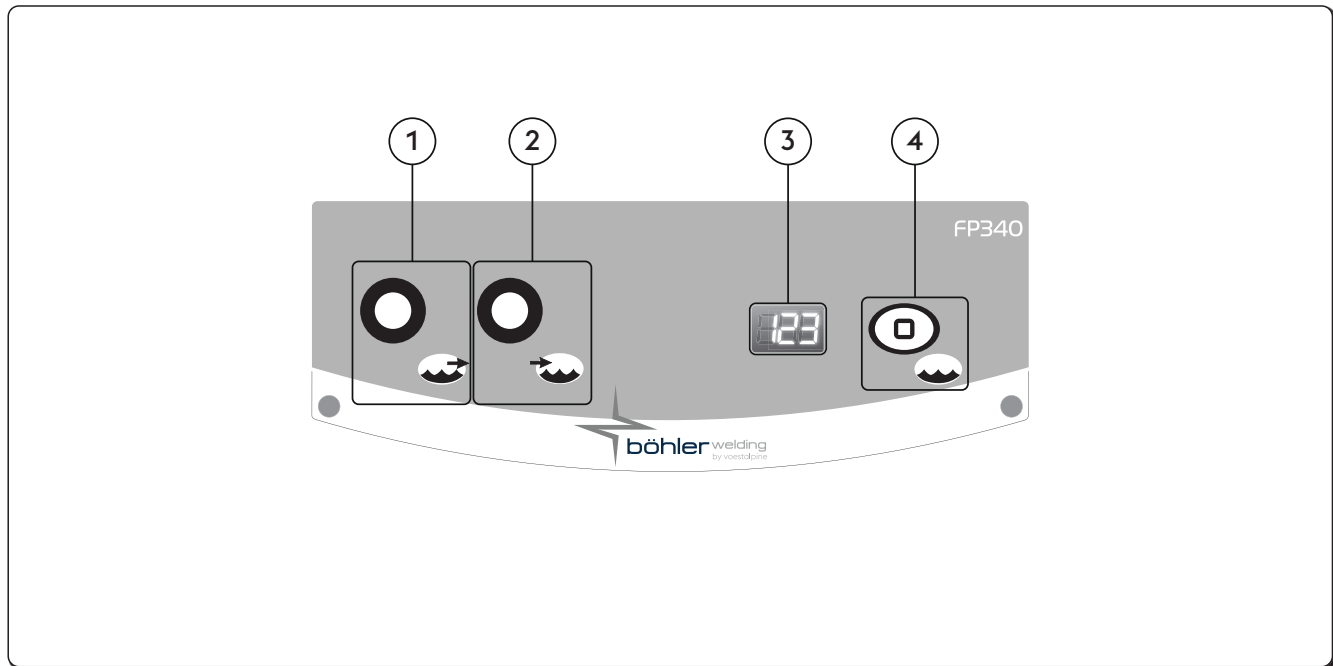

- 1** **Raccordo/innesto uscita liquido refrigerante**
 Permette di immettere liquido a bassa temperatura nel circuito di raffreddamento della torcia.
- 2** **Raccordo/innesto ingresso liquido refrigerante**
 Permette di immettere liquido, che ha subito il riscaldamento della torcia, nel circuito di raffreddamento interno al WU.
- 3** **Display a 7 segmenti**
 Permette di visualizzare le generalità del WU in fase di partenza, il suo corretto funzionamento e la temperatura interna del liquido refrigerante.
 -- Gruppo di raffreddamento disabilitato.
- 4** **Test gruppo di raffreddamento**

4. MANUTENZIONE

- L'impianto deve essere sottoposto ad una manutenzione ordinaria secondo le indicazioni del costruttore. Tutti gli sportelli di accesso e servizio e i coperchi devono essere chiusi e ben fissati quando l'apparecchio è in funzione. L'impianto non deve essere sottoposto ad alcun tipo di modifica. Evitare che si accumulino polvere metallica in prossimità e sulle alette di areazione.
- L'eventuale manutenzione deve essere eseguita esclusivamente da personale qualificato. La riparazione o la sostituzione di parti dell'impianto da parte di personale non autorizzato comporta l'immediata invalidazione della garanzia del prodotto. L'eventuale riparazione o sostituzione di parti dell'impianto deve essere eseguita esclusivamente da personale tecnico qualificato.
- Togliere l'alimentazione all'impianto prima di ogni intervento!**

4.1 Controlli periodici

- Controllare periodicamente il livello del liquido refrigerante nel serbatoio. Il completo svuotamento del serbatoio e/o la presenza di aria nella pompa possono causare il mancato innesco della stessa.
 - Effettuare la pulizia interna utilizzando aria compressa a bassa pressione e pennelli a setola morbida.
 - Controllare le connessioni elettriche e tutti i cavi di collegamento.
 - Controllare le condizioni dell'elettropompa.
 - Controllare lo stato delle connessioni dei tubi.
- Ogni sei mesi, cambiare il liquido di raffreddamento e risciacquare i tubi ed il serbatoio con acqua. Cambiare il liquido nel caso dovesse bollire perché esso perderebbe le proprietà metalliche protettive.



Il riempimento o rabbocco del serbatoio con liquido refrigerante va eseguito con generatore e WU assemblati e posti su di un piano orizzontale.



Il riempimento o rabbocco del serbatoio deve essere eseguito con liquido refrigerante cod. 18.91.008. L'equipaggiamento non deve essere utilizzato senza liquido di raffreddamento.



Non utilizzare liquidi refrigeranti conduttivi.



Effettuare la pulizia interna utilizzando aria compressa a bassa pressione e pennelli a setola morbida. Controllare le connessioni elettriche e tutti i cavi di collegamento.

4.2 Responsabilità



In mancanza di detta manutenzione, decadono tutte le garanzie e comunque il costruttore viene sollevato da qualsiasi responsabilità. Nel caso l'operatore non si attenesse a quanto descritto, il costruttore declina ogni responsabilità. Per ogni dubbio e/o problema non esitare a consultare il più vicino centro di assistenza tecnica.

5. CODIFICA ALLARMI



ALLARME

L'intervento di un allarme o il superamento di un limite di guardia critico causa una segnalazione visiva sul pannello comandi ed il blocco immediato delle operazioni di saldatura.



ATTENZIONE

Il superamento di un limite di guardia causa una segnalazione visiva sul pannello comandi ma consente di continuare le operazioni di saldatura.

Di seguito sono elencati tutti gli allarmi e i tutti i limiti di guardia relativi all'impianto.

E43	Mancanza liquido refrigerante		E71	Sovratemperatura liquido refrigerante	
E76	Livello di flusso liquido refrigerante superato		E77	Livello di temperatura liquido refrigerante	
E81	Sovracorrente (pompa WU)		E82	Errore di comunicazione (WU)	
E83	Pompa bloccata				

6. DIAGNOSTICA E SOLUZIONI

Mancanza di flusso nel circuito

Causa

- » Mancanza di liquido nel serbatoio.
- » Aria nel circuito di raffreddamento.

Soluzione

- » Eseguire il rabbocco.
- » Inserire il by-pass sull'innesto di uscita (colore blu) e sfiatare il circuito idraulico consentendo l'uscita del liquido refrigerante per qualche secondo.

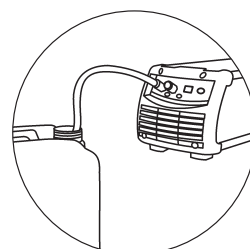

- | | |
|---|---|
| » Circuito di raffreddamento ostruito o interrotto. | » Verificare lo stato delle connessioni (interne al gruppo) del circuito idraulico.
» Verificare lo stato del circuito idraulico della torcia.
» Verificare lo stato del circuito idraulico del fascio cavi.
» Rivolgersi al più vicino centro di assistenza per la riparazione dell'impianto. |
| » Presenza dell'allarme gruppo di raffreddamento. | » Resetare l'allarme.
» Collegare una torcia o il by-pass nelle modalità di funzionamento che prevedono il gruppo di raffreddamento in attività.
» Verificare lo stato delle connessioni (interne al gruppo) del circuito idraulico.
» Verificare lo stato del circuito idraulico della torcia.
» Rivolgersi al più vicino centro di assistenza per la riparazione dell'impianto. |
| » Pompa difettosa. | » Sostituire il componente danneggiato.
» Rivolgersi al più vicino centro di assistenza per la riparazione dell'impianto. |

Insufficiente capacità di raffreddamento







Causa	Soluzione
» Ventilatore difettoso.	» Sostituire il componente danneggiato. » Rivolgersi al più vicino centro di assistenza per la riparazione dell'impianto.
» Pompa difettosa.	» Sostituire il componente danneggiato. » Rivolgersi al più vicino centro di assistenza per la riparazione dell'impianto.

7. CARATTERISTICHE TECNICHE





Caratteristiche elettriche		U.M.
Tensione di alimentazione U1	360	Vdc
Corrente massima assorbita I1max	0.4	A
Potenza di raffreddamento (25°C)	1000	W
Caratteristiche fisiche		U.M.
Grado di protezione IP	IP23S	
Dimensioni (lxwxh)	660x240x220	mm
Peso	12.0	Kg
Tipo di scambiatore	H ₂ O - Aria	
Portata nominale (QV)	2.3	l/min
Portata massima pompa (Qvmax)	4.6	l/min
Prevalenza pompa (Hmax)	35	m
Tipo pompa	Rotativa	
N° giri massimo	3300	RPM
Capacità serbatoio	3.0	l
Norme di costruzione	EN IEC 60974-2:2019 EN 60974-10/A1:2015	

8. TARGA DATI

IT

 VOESTALPINE BÖHLER WELDING ARC TECHNOLOGY S.R.L. Via Palladio,19 - ONARA (PADOVA) - ITALY						
WU 2000		N°				
<table border="1"> <tr> <td>EN</td> <td>60974-2:2019</td> </tr> <tr> <td>IEC</td> <td>60974-10/A1:2015 Class A</td> </tr> </table>	EN	60974-2:2019	IEC	60974-10/A1:2015 Class A		
EN	60974-2:2019					
IEC	60974-10/A1:2015 Class A					
Energy input						
	U₁ 350V	I_{1max} 0.35A				
	IP 23 S					
Liquid cooling system						
	P_{11/min} 1.0kW	P_{max} 0.35MPa (3.5bar)				
  						
MADE IN ITALY 						

9. SIGNIFICATO TARGA DATI

1		2	
3		4	
5			
6			
6	7	8	
	9		
10			
10	11	12	
  			
MADE IN ITALY 			

- 1 Marchio di fabbricazione
- 2 Nome ed indirizzo del costruttore
- 3 Modello dell'apparecchiatura
- 4 N° di serie
XXXXXXXXXXXX Anno di fabbricazione
- 5 Riferimento alle norme di costruzione
- 6 Simbolo per l'alimentazione
- 7 Tensione nominale d'alimentazione
- 8 Massima corrente nominale d'alimentazione
- 9 Grado di protezione
- 10 Simbolo per il raffreddamento
- 11 Potenza di raffreddamento
- 12 Pressione massima

CE Dichiarazione di conformità EU
 EAC Dichiarazione di conformità EAC
 UKCA Dichiarazione di conformità UKCA

EU-KONFORMITÄTSERKLÄRUNG

Der Bauarbeiter
voestalpine Böhler Welding Arc Technology S.r.l.
Via Palladio, 19 - 35019 Onara di Tombolo (PD) - ITALY
Tel. +39 049 9413/111 - Fax +39 049 9413/311 - www.voestalpine.com/welding

DE

erklärt unter seiner alleinigen Verantwortung, dass das folgende Produkt:

WU 2000

71.03.076

den folgenden EU Richtlinien entspricht:

2014/35/EU LOW VOLTAGE DIRECTIVE

2014/30/EU EMC DIRECTIVE

2011/65/EU RoHS DIRECTIVE

dass die folgenden harmonisierten Normen angewendet wurden:

EN IEC 60974-2:2019

LIQUID COOLING SYSTEMS

EN 60974-10/A1:2015

ELECTROMAGNETIC COMPATIBILITY REQUIREMENTS

Die Dokumentation, die die Einhaltung der Richtlinien bescheinigt, wird beim oben genannten Hersteller für Inspektionen aufbewahrt.

Jede von der Firma voestalpine Böhler Welding Arc Technology S.r.l. nicht genehmigte Änderung hebt die Gültigkeit dieser Erklärung auf.

Onara di Tombolo, 01/05/2025

voestalpine Böhler Welding Arc Technology S.r.l.



Mirco Frasson

Ivo Bonello

Managing Directors

INDEX

1. WARNUNG	31
1.1 Arbeitsumgebung	31
1.2 Persönlicher Schutz und Schutz Dritter.....	31
1.3 Schutz vor Elektrischem Schlag.....	32
1.4 Elektromagnetische Felder und Störungen	32
1.5 Schutzart IP	32
1.6 Kühlflüssigkeit	32
2. INSTALLATION	33
2.1 Heben, Transportieren und Abladen	33
2.2 Aufstellen der Anlage.....	33
2.3 Elektrischer Anschluss.....	33
2.4 Inbetriebnahme	33
3. PRÄSENTATION DER ANLAGE.....	35
3.1 Hintere Ansicht.....	35
3.2 Frontbedienfeld.....	36
4. WARTUNG	36
4.1 Führen Sie folgende regelmäßige Überprüfungen am Generator durch	36
4.2 Verantwortung.....	37
5. ALARMCODES	37
6. FEHLERSUCHE.....	37
7. TECHNISCHE DATEN.....	38
8. DATENSCHILD	39
9. BEDEUTUNG DER ANGABEN AUF DEM LEISTUNGSSCHILD	39
10. SCHALTPLAN	149
11. VERBINDER.....	150
12. ERSATZTEILVERZEICHNIS	151

DE

SYMBOLE

-  Warnung
-  Verbote
-  Verpflichtungen
-  Allgemeine Hinweise

1. WARNUNG



Vor Arbeitsbeginn lesen Sie das Anleitungsheft sorgfältig durch und vergewissern Sie sich, ob Sie alles richtig verstanden haben.
Nehmen Sie keine Änderungen vor und führen Sie keine hier nicht beschriebenen Instandhaltungsarbeiten durch. Der Hersteller haftet nicht für Personen- oder Sachschäden, die durch unsachgemäßen Gebrauch oder Nichteinhaltung der Vorgaben dieser Anleitung seitens des Benutzers verursacht werden.
Die Bedienungsanleitung ist ständig am Einsatzort des Gerätes aufzubewahren. Ergänzend zur Bedienungsanleitung sind die allgemein gültigen sowie die örtlichen Regeln zu Unfallverhütung und Umweltschutz zu beachten.
Die Firma voestalpine Böhler Welding Arc Technology S.r.l. behält sich das Recht vor, jederzeit und ohne Vorankündigung Änderungen in dieser Anleitung vorzunehmen.
Die Übersetzungen, Nachdruck und Bearbeitungsrechte liegen bei der Firma voestalpine Böhler Welding Arc Technology S.r.l. und Reproduktionen ohne schriftliche Genehmigung seitens der Firma voestalpine Böhler Welding Arc Technology S.r.l. sind in jeglicher Form (einschließlich Fotokopien, Filme und Mikrofilme) komplett oder auszugsweise verboten.
Die hier aufgeführten Vorschriften sind von grundlegender Bedeutung und notwendig, um den Garantieanspruch zu sichern.
Im Fall von unsachgemäßem Gebrauch oder Nichteinhaltung der Vorschriften seitens des Benutzers, lehnt der Hersteller jegliche Haftung ab.



Alle Personen, die mit der Inbetriebnahme, Bedienung, Wartung und Instandhaltung des Gerätes zu tun haben, müssen:

- entsprechend qualifiziert sein
- diese Bedienungsanleitung vollständig lesen und genau befolgen

Bei Fragen oder Unklarheiten im Umgang mit dem Gerät wenden Sie sich an Fachpersonal.

1.1 Arbeitsumgebung



Die gesamte Anlage darf ausschließlich für den Zweck verwendet werden, für den sie konzipiert wurde, auf die Art und in dem Umfang, der auf dem Leistungsschild und/oder im vorliegenden Handbuch festgelegt ist und gemäß den nationalen und internationalen Sicherheitsvorschriften. Ein anderer Verwendungszweck, als der ausdrücklich vom Hersteller angegebene, ist unsachgemäß und gefährlich. Der Hersteller übernimmt in solchen Fällen keinerlei Haftung.



Dieses Gerät darf nur für gewerbliche Zwecke im industriellen Umfeld angewendet werden. Der Hersteller haftet nicht für Schäden, die durch den Gebrauch der Anlage im Haushalt verursacht wurden.



Die Anlage darf nur bei Umgebungstemperaturen zwischen -10°C und +40°C (zwischen +14°F und +104°F) benutzt werden.
Die Anlage darf nur bei Umgebungstemperaturen zwischen -25°C und +55°C (zwischen -13°F und 131°F) befördert und gelagert werden.
Die Anlage darf nur in einer Umgebung benutzt werden, die frei von Staub, Säure, Gas und ätzenden Substanzen ist.
Die Anlage darf nicht in einer Umgebung mit einer relativen Luftfeuchte über 50% bei 40°C (104°F) benutzt werden.
Die Anlage darf nicht in einer Umgebung mit einer relativen Luftfeuchte über 90% bei 20°C (68°F) benutzt werden.
Die Anlage darf nicht in einer Höhe von mehr als 2000m über NN (6500 Fuß) benutzt werden.

1.2 Persönlicher Schutz und Schutz Dritter



Sicherstellen, dass der Brenner abgekühlt ist, bevor daran Arbeiten oder Wartungen ausgeführt werden.



Sicherstellen, dass das Kühlaggregat ausgeschaltet ist, bevor die Leitungen für den Vor- und Rücklauf der Kühlflüssigkeit abgetrennt werden. Die austretende heiße Flüssigkeit kann schwere Verbrennungen verursachen.



Einen Verbandkasten griffbereit halten.
Verbrennungen oder Verletzungen sind nicht zu unterschätzen.



Vor dem Verlassen des Arbeitsplatzes muss dieser gesichert werden, um Personen- und Sachschäden zu vermeiden.

1.3 Schutz vor Elektrischem Schlag



Ein Stromschlag kann tödlich sein.

- Üblicherweise unter Spannung stehende Innen- oder Außenteile der gespeisten Schweißanlage nicht berühren (Brenner, Zangen, Massekabel, Elektroden, Draht, Rollen und Spulen sind elektrisch mit dem Schweißstromkreis verbunden).
- Die elektrische Isolierung der Anlage durch Benutzung trockener und ausreichend vom Erd- und Massepotential isolierter Flächen und Untergestelle sicherstellen.

1.4 Elektromagnetische Felder und Störungen

1.4.1 EMV in Übereinstimmung mit: EN 60974-10/A1:2015.

Klasse B

Anlagen der Klasse B entsprechen den elektromagnetischen Kompatibilitätsanforderungen in Mischgebieten, einschließlich Wohngebieten, in denen die elektrische Leistung von dem öffentlichen Niederspannungsversorgungsnetz geliefert wird.

Klasse A

Anlagen der Klasse A sind nicht für die Nutzung in Wohngebieten konzipiert, in denen die elektrische Leistung vom öffentlichen Niederspannungsversorgungsnetz geliefert wird. Es können potenzielle Schwierigkeiten beim Sicherstellen der elektromagnetischen Kompatibilität von Anlagen der Klasse A in diesen Umgebungen auftreten, aufgrund der ausgestrahlten Störgrößen.

Weitere Informationen finden Sie unter: DATENSCHILD oder TECHNISCHE DATEN.

1.4.2 Installation, Gebrauch und Bewertung des Bereichs

Dieses Gerät ist in Übereinstimmung mit den Angaben der harmonisierten Norm hergestellt EN 60974-10/A1:2015 und als Gerät der "KLASSE A" gekennzeichnet. Dieses Gerät darf nur für gewerbliche Zwecke im industriellen Umfeld angewendet werden. Der Hersteller haftet nicht für Schäden, die durch den Gebrauch der Anlage im Haushalt verursacht wurden.



Der Benutzer muss ein erfahrener Fachmann auf dem Gebiet sein und ist als solcher für die Installation und den Gebrauch des Geräts gemäß den Herstelleranweisungen verantwortlich. Wenn elektromagnetische Störungen festgestellt werden, muss der Benutzer des Gerätes das Problem lösen, wenn notwendig mit Hilfe des Kundendienstes des Herstellers.



In jedem Fall müssen die elektromagnetischen Störungen soweit reduziert werden, bis sie keine Belästigung mehr darstellen.



Bevor das Gerät installiert wird, muss der Benutzer die möglichen elektromagnetischen Probleme, die sich im umliegenden Bereich ergeben können, und insbesondere die Gesundheit, der sich in diesem Bereich aufhaltenden Personen - Träger von Schrittmachern und Hörgeräten - prüfen.

1.4.3 Abschirmung

Durch die selektive Abschirmung anderer Kabel und Geräte im umliegenden Bereich lassen sich die Probleme durch elektromagnetische Störungen reduzieren.

Die Abschirmung der gesamten Schweißanlage kann in besonderen Fällen in Betracht gezogen werden.

1.5 Schutzart IP

IP

IP23S

- Gehäuse mit Schutz gegen Berührung gefährlicher Teile mit den Fingern und vor dem Eindringen von Fremdkörpern mit einem Durchmesser größer/gleich 12,5 mm.
- Gehäuse mit Schutz gegen Sprühwasser bis zu einem Winkel von 60° in Bezug auf die Senkrechte.
- Gehäuse mit Schutz gegen Schäden durch eindringendes Wasser, wenn die beweglichen Teile der Anlage im Stillstand sind.

1.6 Kühlflüssigkeit

1.6.1 Personenschutz



Eine Einnahme des Produktes ist schädlich.
Es kann Augen, Schleimhäute und die Haut reizen.



Tragen Sie Gummihandschuhe, um einen Kontakt zu vermeiden.



Setzen Sie eine Schutzbrille auf, um sich vor Spritzern zu schützen.



Tragen Sie gebräuchliche Arbeitskleidung, um Hautkontakt zu vermeiden.

1.6.2 Entsorgung



Das Elektrogerät nicht in den normalen Hausmüll geben!

Gemäß der europäischen Richtlinie 2012/19/EU über Elektro- und Elektronik-Altgeräte und der Umsetzung dieser Richtlinie in innerstaatliches Recht müssen die Geräte am Ende ihrer Nutzungsdauer getrennt gesammelt und einer Verwertungs- und Recyclingstelle zugeführt werden. Der Eigentümer des Geräts muss die autorisierten Sammelstellen durch Kontaktnahme der örtlichen Behörden in Erfahrung bringen. Durch die Einhaltung der Europäischen Richtlinie schützen Sie die Umwelt und die Gesundheit Ihrer Mitmenschen.



Ausgelaufene Kühlflüssigkeit, Produktreste und gebrauchte Kühlflüssigkeit müssen in einer geeigneten Kläranlage behandelt oder, falls möglich, recycled werden. Das gebrauchte Produkt nicht Gewässern, Gräben oder in Entwässerungssystemen entsorgen. Die verdünnte Flüssigkeit nicht in die Kanalisation geben, außer es wird von den örtlichen Vorschriften erlaubt.

2. INSTALLATION

2.1 Heben, Transportieren und Abladen

- Die Anlage hat keine speziellen Hebevorrichtungen.



Das Gewicht der Anlage ist nicht zu unterschätzen, siehe Technische Daten.

Bewegen oder platzieren Sie die angehängte Last nicht über Personen oder Gegenständen.

Lassen Sie das Gerät/die Anlage nicht fallen und üben Sie keinen übermäßigen Druck auf die Anlage aus.

2.2 Aufstellen der Anlage



Folgende Vorschriften beachten:

- Sorgen Sie für freien Zugang zu den Bedienelementen und Anschlüssen.
- Stellen Sie die Anlage nicht in engen Räumen auf.
- Stellen Sie die Anlage nie auf einer Fläche mit einer Neigung von mehr als 10° auf.
- Stellen Sie die Anlage an einem trockenen und sauberen Ort mit ausreichender Belüftung auf.
- Schützen Sie die Anlage vor strömenden Regen und Sonne.
- » Siehe Abschnitt "Schutzmaßnahmen im Umgang mit Gasflaschen".

2.3 Elektrischer Anschluss



Trennen Sie die Anlage von der Stromzufuhr vor jedem Wartungseingriff!

2.4 Inbetriebnahme

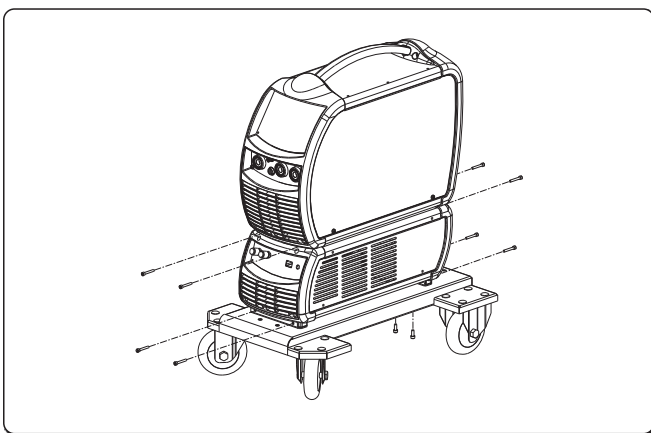

- ▶ Den WU auf den GT legen und mit den 4 Schrauben befestigen.
- ▶ Den Generator auf dem Kühlaggregat platzieren und mittels Schrauben befestigen.

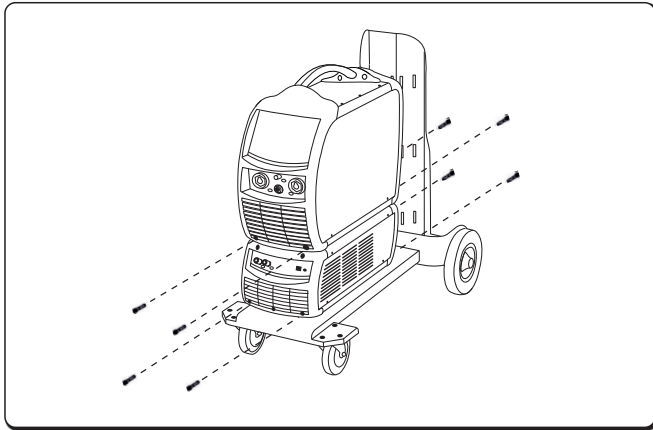

- ▶ Den WU auf den GT legen und mit den 4 Schrauben befestigen.
- ▶ Den Generator auf dem Kühlaggregat platzieren und mittels Schrauben befestigen.

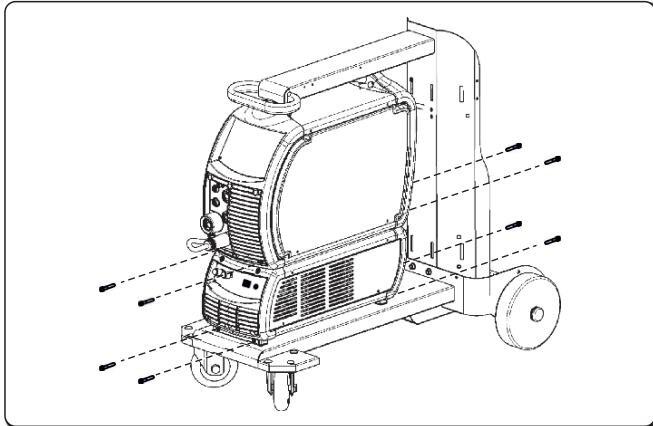

- ▶ Den WU auf den GT legen und mit den 4 Schrauben befestigen.
- ▶ Den Generator auf dem Kühlaggregat platzieren und mittels Schrauben befestigen.

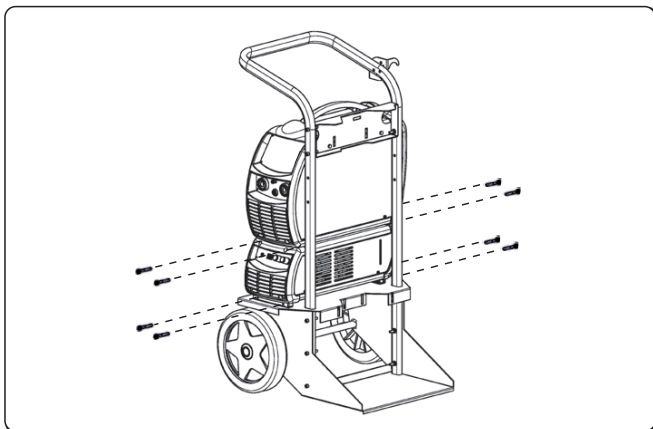

- ▶ Den WU auf den GT legen und mit den 4 Schrauben befestigen.
- ▶ Den Generator auf dem Kühlaggregat platzieren und mittels Schrauben befestigen.



Führen Sie folgende Schritte vorm Einschalten der Anlage durch:

- ▶ Den Tankverschluss entfernen.
- ▶ Den Dichtstopfen von der Einfüllöffnung entfernen, indem Sie den Rand des Stopfens mit einem Werkzeug anhebe.
- ▶ Gegebenenfalls Kühlflüssigkeit im Tank nachfüllen.
- ▶ Bewahren Sie den Dichtstopfen für spätere Transporte der Anlage auf.



Um Schäden am Kühlaggregat zu vermeiden, montieren Sie immer den Bypass-Schlauch, wenn der Brenner nicht mit den Kühlmittelanschlüssen verbunden ist.



Das Füllen oder Nachfüllen des Tanks muss mit Kühlflüssigkeit Code 18.91.008 ausgeführt werden.

2.4.1 Anschluss rückseitiges Bedienfeld

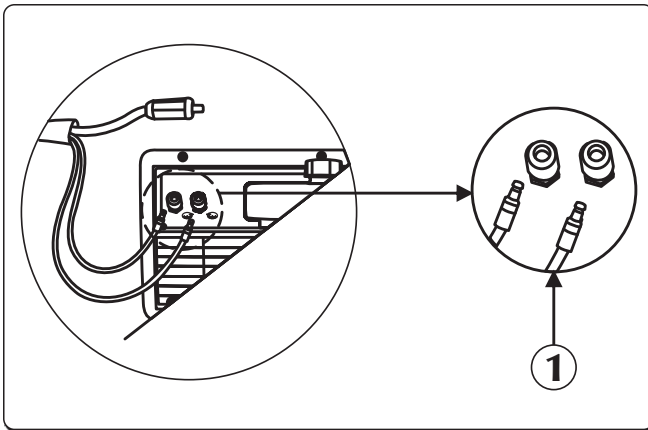

① Vor- und Rücklauf Kühlmittel

- ▶ Den blauen Schlauch des Schlauchpaketes mit dem entsprechenden Schnellverbinder für den Rücklauf der Kühlflüssigkeit (blau) verbinden.
- ▶ Den roten Schlauch des Schlauchpaketes mit dem entsprechenden Schnellverbinder für den Rücklauf der Kühlflüssigkeit (rot) verbinden.

2.4.2 Anschluss frontseitiges Bedienfeld

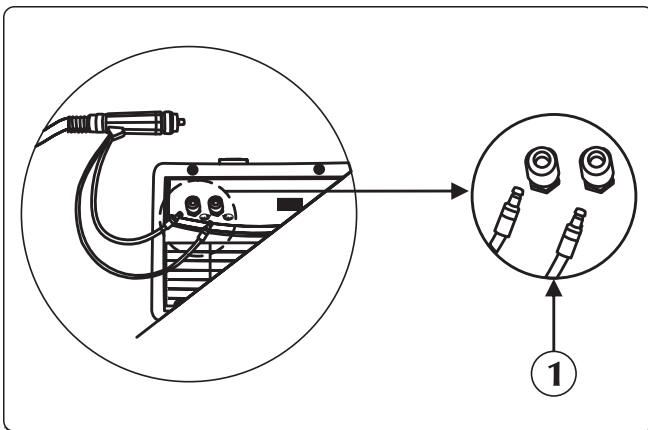

① Vor- und Rücklauf Kühlmittel

- ▶ Den blauen Schlauch (Vorlauf der Kühlflüssigkeit) des Brenners mit dem entsprechenden Schnellverbinder (blau) verbinden.
- ▶ Den roten Schlauch (Rücklauf der Kühlflüssigkeit) des Brenners mit dem entsprechenden Schnellverbinder (rot) verbinden.

3. PRÄSENTATION DER ANLAGE

3.1 Hintere Ansicht

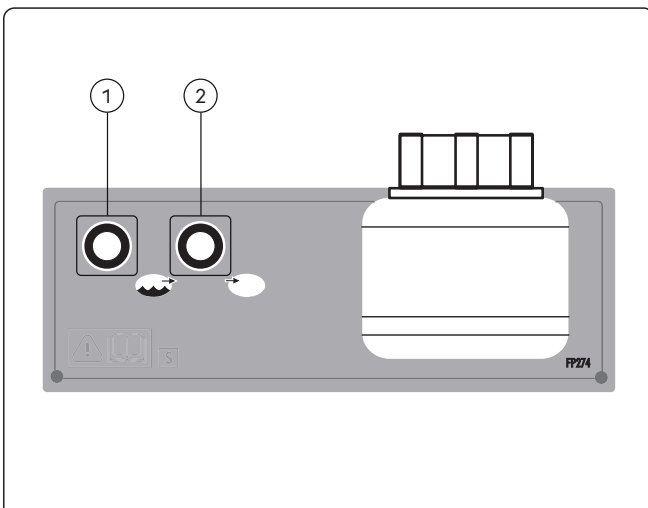

① Anschluss Kühlmittelvorlauf

Ermöglicht die Zuführung von kalter Flüssigkeit in den Kühlkreislauf des Brenners.

② Anschluss Kühlmittelrücklauf

Ermöglicht die Rückführung der im Schweißbrenner erwärmten Flüssigkeit in den Kühlkreislauf der WU.

DE

3.2 Frontbedienfeld

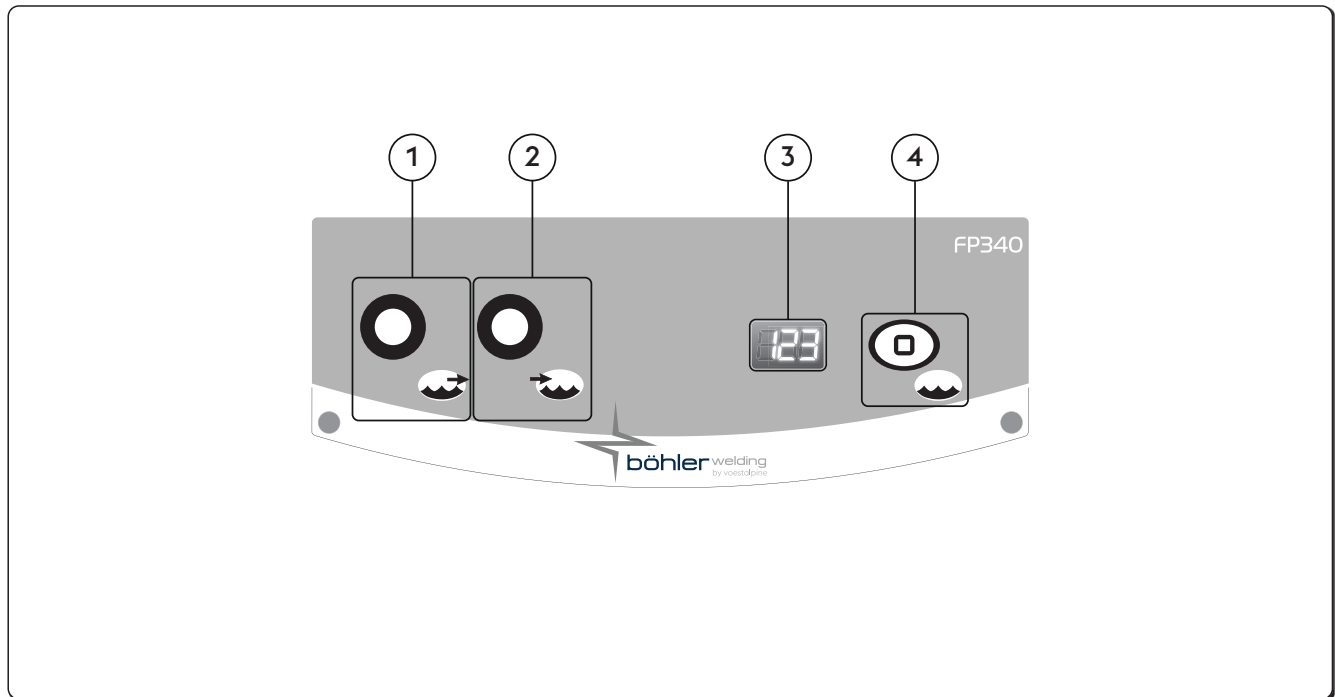

- 1 Anschluss Kühlmittelvorlauf**
 Ermöglicht die Zuführung von kalter Flüssigkeit in den Kühlkreislauf des Brenners.
- 2 Anschluss Kühlmittelrücklauf**
 Ermöglicht die Rückführung der im Schweißbrenner erwärmten Flüssigkeit in den Kühlkreislauf der WU.
- 3 7-Segment-Anzeige**
 Ermöglicht die Anzeige der allgemeinen Parameter der Drahtvorschubeinheit während des Startens, dessen korrekte Funktion und die Anzeige der internen Kühlmitteltemperatur.
 -- Kühleinheit ist inaktiv.
- 4 Test Kühlaggregat**

4. WARTUNG

- Die regelmäßige Wartung der Anlage muss nach den Angaben des Herstellers erfolgen. Wenn das Gerät in Betrieb ist, müssen alle Zugangs-, Wartungstüren und Abdeckungen geschlossen und verriegelt sein. Die Anlage darf keiner Änderung unterzogen werden. Vermeiden Sie Ansammlungen von Metallstaub in der Nähe und über den Lüftungsschlitzen.
- Jeder Wartungseingriff darf nur von Fachpersonal ausgeführt werden. Das Reparieren oder Austauschen von Anlageteilen durch unautorisiertes Personal hebt die Produktgarantie auf. Das Reparieren oder Austauschen von Anlageteilen darf ausschließlich von Fachpersonal ausgeführt werden.
- Trennen Sie die Anlage von der Stromzufuhr vor jedem Wartungseingriff!**

4.1 Führen Sie folgende regelmäßige Überprüfungen am Generator durch

- Den Kühlfüllstandsstand im Behälter regelmäßig prüfen. Wenn der Kühlfüllstandsbehälter ganz leer ist und/oder Luft im Kühlkreislauf vorhanden ist, kann dies zu Funktionsstörungen der Pumpe führen.
 - Das Innere der Anlage mittels Druckluft mit niederem Druck und weichen Pinseln reinigen.
 - Elektrische Verbindungen und Anschlusskabel prüfen.
 - Den Zustand der Elektropumpe überprüfen.
 - Den Zustand der Schlauchverbindungen überprüfen.
- Alle sechs Monate die Kühlfüllstand wechseln und die Schläuche und den Tank mit Wasser säubern. Sollte die Kühlfüllstand einmal gekocht haben, ist sie auszutauschen, da sie sonst ihre Korrosionsschutzeigenschaften verliert.



Das Füllen oder Nachfüllen des Tanks mit Kühlflüssigkeit darf nur mit zusammengebautem Generator und WU und auf einer horizontalen Fläche erfolgen.



Das Füllen oder Nachfüllen des Tanks muss mit Kühlflüssigkeit Code 18.91.008 ausgeführt werden. Die Anlage darf nie ohne Kühlflüssigkeit eingesetzt werden.



Keine leitfähigen Kühlflüssigkeiten verwenden.



Das Innere der Anlage mittels Druckluft mit niederem Druck und weichen Pinseln reinigen. Elektrische Verbindungen und Anschlusskabel prüfen.

4.2 Verantwortung



Durch Unterlassung der oben genannten Wartung wird jegliche Garantie aufgehoben und der Hersteller wird von jeglicher Haftung befreit. Der Hersteller übernimmt keinerlei Haftung, falls sich der Benutzer nicht an diese Vorschriften hält. Wenden Sie sich bei jedem Zweifel und/oder bei jedem Problem an die nächstgelegene Technische Kundendienststelle.

5. ALARMCODES



ALARM















Die Auslösung eines Alarms bzw. das Überschreiten einer kritischen Warnschwelle hat eine entsprechende Anzeige am Bedienfeld sowie den sofortigen Abbruch der Schweißvorgänge zur Folge.



ACHTUNG

Das Überschreiten einer Schutzgrenze verursacht ein visuelles Signal auf dem Bedienfeld, ermöglicht jedoch die Fortsetzung der Schweißvorgänge.

Nachstehend sind alle Alarmer und Warnschwellen der Anlage aufgelistet.

 E43	Kühlmittelmangel		 E71	Übertemperatur des Kühlmittels	
 E76	Kühlmitteldurchflussgrenze überschritten		 E77	Kühlmitteltemperaturgrenze überschritten	
 E81	Überstrom (Pump-WU)		 E82	Kommunikationsfehler (WU)	
 E83	Pump-blockiert				

6. FEHLERSUCHE

Kein Durchfluss im Kühlkreislauf

Ursache

- » Kein Kühlmittel im Tank.
- » Luft im Kühlmittelkreislauf.

Lösung

- » Nachfüllen.
- » Verbinden Sie den Bypass-Schlauch mit dem Anschluss (blau) und zapfen Sie den Kühlmittelkreislauf an, um die Kühlflüssigkeit für einige Sekunden austreten zu lassen.

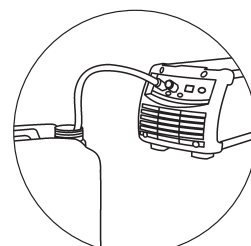

- | | |
|--|---|
| <ul style="list-style-type: none"> » Kühlmittelkreislauf verstopft oder unterbrochen. | <ul style="list-style-type: none"> » Überprüfen Sie den Zustand der Verbindungen (innerhalb der Kühleinheit) des Kühlmittelkreislaufes. » Überprüfen Sie den Zustand des Brenner-Kühlmittelkreislaufes. » Überprüfen Sie den Zustand des Kabelbündel-Kühlmittelkreislaufes. » Anlage von der nächstgelegenen Kundendienststelle reparieren lassen. |
| <ul style="list-style-type: none"> » Alarm Kühleinheit steht an. | <ul style="list-style-type: none"> » Den Alarm zurücksetzen. » Schließen Sie in den Betriebsarten, die eine aktive Kühleinheit erfordern, den Brenner oder Bypass-Schlauch an. » Überprüfen Sie den Zustand der Verbindungen (innerhalb der Kühleinheit) des Kühlmittelkreislaufes. » Überprüfen Sie den Zustand des Brenner-Kühlmittelkreislaufes. » Anlage von der nächstgelegenen Kundendienststelle reparieren lassen. |
| <ul style="list-style-type: none"> » Pumpe defekt. | <ul style="list-style-type: none"> » Schadhafes Teil ersetzen. » Anlage von der nächstgelegenen Kundendienststelle reparieren lassen. |

Unzureichende Kühlkapazität

Ursache

- » Gebläse defekt.
- » Pumpe defekt.

Lösung







- » Schadhafes Teil ersetzen.
- » Anlage von der nächstgelegenen Kundendienststelle reparieren lassen.
- » Schadhafes Teil ersetzen.
- » Anlage von der nächstgelegenen Kundendienststelle reparieren lassen.

7. TECHNISCHE DATEN





Elektrische Eigenschaften			U.M.
Versorgungsspannung U1	360		Vdc
Max. Stromaufnahme I1max	0.4		A
Kälteleistung (25°C)	1000		W
Physikalische Eigenschaften			U.M.
Schutzart IP	IP23S		
Abmessungen (LxBxH)	660x240x220		mm
Gewicht	12.0		Kg
Austauschertyp	H ₂ O - Luft		
Nennförderleistung (QV)	2.3		l/min
Pumpenhöchstförderleistung (Qvmax)	4.6		l/min
Pumpenförderhöhe (Hmax)	35		m
Pumpentyp	Kreisel		
Max. Drehzahl	3300		RPM
Fassungsvermögen des Tanks	3.0		l
Konstruktionsnormen	EN IEC 60974-2:2019 EN 60974-10/A1:2015		

8. DATENSCHILD

DE

 VOESTALPINE BÖHLER WELDING ARC TECHNOLOGY S.R.L. Via Palladio, 19 - ONARA (PADOVA) - ITALY		
WU 2000		N°
EN IEC	60974-2:2019 60974-10/A1:2015 Class A	
Energy input		
	U₁ 350V	I_{1max} 0.35A
	IP 23 S	
Liquid cooling system		
	P_{11/min} 1.0kW	P_{max} 0.35MPa (3.5bar)
		  
		MADE IN ITALY 

9. BEDEUTUNG DER ANGABEN AUF DEM LEISTUNGSSCHILD

1		2	
3		4	
5			
6			
6	7	8	
	9		
10			
10	11	12	
		  	
		MADE IN ITALY 	

- 1 Marke
- 2 Herstellername und -adresse
- 3 Gerätemodell
- 4 Seriennummer
XXXXXXXXXXXXXX Baujahr
- 5 Hinweis auf die Konstruktionsnormen
- 6 Symbol der Stromversorgung
- 7 Versorgungs-Nennspannung
- 8 Maximale Nennstromaufnahme
- 9 Schutzart
- 10 Kühlsystem-Symbol
- 11 Kälteleistung
- 12 Höchstdruck

CE EU-Konformitätserklärung
 EAC EAC-Konformitätserklärung
 UKCA UKCA-Konformitätserklärung

DÉCLARATION DE CONFORMITÉ UE

Le constructeur
voestalpine Böhler Welding Arc Technology S.r.l.
Via Palladio, 19 - 35019 Onara di Tombolo (PD) - ITALY
Tél. +39 049 9413/111 - Fax +39 049 9413/311 - www.voestalpine.com/welding

déclare sous sa seule responsabilité que le produit suivant:

WU 2000

71.03.076

est conforme aux directives EU:

2014/35/EU LOW VOLTAGE DIRECTIVE

2014/30/EU EMC DIRECTIVE

2011/65/EU RoHS DIRECTIVE

et que les normes harmonisées suivantes ont été appliquées:

EN IEC 60974-2:2019

LIQUID COOLING SYSTEMS

EN 60974-10/A1:2015

ELECTROMAGNETIC COMPATIBILITY REQUIREMENTS

La documentation certifiant le respect des directives sera tenue à disposition pour les inspections chez le fabricant susmentionné.

Toute intervention ou modification non autorisée par voestalpine Böhler Welding Arc Technology S.r.l. annulera la validité de cette déclaration.

Onara di Tombolo, 01/05/2025

voestalpine Böhler Welding Arc Technology S.r.l.



Mirco Frasson

Ivo Bonello

Managing Directors

INDEX GENERAL

1. AVERTISSEMENT	43
1.1 Environnement d'utilisation	43
1.2 Protection individuelle et de l'entourage	43
1.3 Protection contre les décharges électriques	44
1.4 Champs électromagnétiques et interférences	44
1.5 Degré de protection IP.....	44
1.6 Liquide de refroidissement	44
2. INSTALLATION	45
2.1 Mode de soulèvement, de transport et de déchargement	45
2.2 Installation de l'appareil.....	45
2.3 Branchement et raccordement.....	45
2.4 Mise en service	45
3. PRÉSENTATION DE L'APPAREIL.....	47
3.1 Panneau arrière	47
3.2 Panneau de commande frontal.....	48
4. ENTRETIEN	48
4.1 Contrôles périodiques sur le générateur	48
4.2 Responsabilité	49
5. CODES D'ALARME.....	49
6. DIAGNOSTIC ET SOLUTIONS	49
7. CARACTÉRISTIQUES TECHNIQUES	50
8. PLAQUE DONNÉES	51
9. SIGNIFICATION DE LA PLAQUE DES DONNÉES.....	51
10. SCHÉMA.....	149
11. CONNECTEURS.....	150
12. LISTE DE PIÈCES DÉTACHÉES.....	151

FR

SYMBOLOGIE



Avertissement



Interdictions



Obligations



Indications générales

1. AVERTISSEMENT



Avant de commencer toute opération, assurez-vous d'avoir bien lu et bien compris ce manuel.

N'apportez pas de modification et n'effectuez pas d'opération de maintenance si elles ne sont pas indiquées dans ce manuel. Le fabricant n'est pas responsable des dommages causés aux personnes ou aux objets en cas de non-respect ou de mise en pratique incorrecte des instructions de ce manuel.

Les Instructions de service doivent être conservées en permanence sur le lieu d'utilisation de l'appareil. En complément des présentes instructions de service, les règles générales et locales en vigueur concernant la prévention des accidents et la protection de l'environnement doivent être respectées.

voestalpine Böhler Welding Arc Technology S.r.l. se réserve le droit d'apporter des modifications à tout moment et sans aucun préavis.

Les droits de traduction, de reproduction totale ou partielle quels que soient les moyens (y compris les photocopies, les films et les microfilms) sont réservés et interdits sans l'autorisation écrite de voestalpine Böhler Welding Arc Technology S.r.l.

Ce qui est reporté ci-dessous est très important et donc nécessaire afin que la garantie puisse être valable.

Le fabricant décline toute responsabilité si l'opérateur ne respecte pas les indications.



Toutes les personnes concernées par la mise en service, l'utilisation, la maintenance et la remise en état de l'appareil doivent:

- posséder les qualifications correspondantes
- lire attentivement et suivre avec précision les prescriptions des présentes Instructions de service

Prière de consulter du personnel qualifié en cas de doute ou de problème sur l'utilisation de l'installation, même si elle n'est pas décrite ici.

FR

1.1 Environnement d'utilisation



Chaque installation ne doit être utilisée que dans le but exclusif pour lequel elle a été conçue, de la façon et dans les limites prévues sur la plaque signalétique et/ou dans ce manuel, selon les directives nationales et internationales relatives à la sécurité. Un usage autre que celui expressément déclaré par le fabricant doit être considéré comme inapproprié et dangereux et décharge ce dernier de toute responsabilité.



Cet appareil doit être utilisé exclusivement dans un but professionnel, dans un environnement industriel. Le fabricant n'est pas responsable des dommages causés en cas d'usage domestique.



L'installation doit être utilisée dans un local dont la température est comprise entre -10 et +40°C (entre +14 et +104°F).

L'installation doit être transportée et stockée dans un local dont la température est comprise entre -25 et +55°C (entre -13 et 131°F).

L'installation doit être utilisée dans un local sans poussière, ni acide, ni gaz ou autres substances corrosives.

L'installation ne doit pas être utilisée dans un local dont le taux d'humidité dépasse 50% à 40°C (104°F).

L'installation ne doit pas être utilisée dans un local dont le taux d'humidité dépasse 90% à 20°C (68°F).

L'installation ne doit pas être utilisée à une altitude supérieure à 2000 m au dessus du niveau de la mer (6500 pieds).

1.2 Protection individuelle et de l'entourage



S'assurer que la torche est froide avant d'intervenir dessus ou d'effectuer une opération d'entretien quelconque.



S'assurer que le groupe de refroidissement est éteint avant de déconnecter les tuyaux de circulation du liquide réfrigérant. Le liquide chaud en sortie pourrait provoquer des brûlures graves.



Avoir à disposition une trousse de secours.

Ne pas sous-estimer les brûlures ou les blessures.



Avant de quitter le poste de travail, sécuriser la zone afin d'empêcher tout risque d'accident ou de dommages aux personnes ou aux biens.

1.3 Protection contre les décharges électriques



Une décharge électrique peut être mortelle.

- Éviter de toucher les parties normalement sous tension à l'intérieur ou à l'extérieur de l'installation de soudage quand cette dernière est alimentée (les torches, les pinces, les câbles de masse, les électrodes, les fils, les galets et les bobines sont branchés au circuit de soudage).
- Garantir l'isolation de l'installation et de l'opérateur en utilisant des sols et des plans secs et suffisamment isolés de la terre.

1.4 Champs électromagnétiques et interférences

1.4.1 Classification CEM selon la norme: EN 60974-10/A1:2015.

Classe
B

Los dispositivos de clase B cumplen con los requisitos de compatibilidad electromagnética en entornos industriales y residenciales, incluyendo las áreas residenciales en las que la energía eléctrica se suministra desde un sistema público de baja tensión.

Classe
A

Los dispositivos de clase A no están destinados al uso en áreas residenciales en las que la energía eléctrica se suministra desde un sistema público de baja tensión. Il pourrait être difficile d'assurer la compatibilité électromagnétique d'appareils de classe A dans de tels environnements, en raison de perturbations par rayonnement ou conduction.

Pour plus d'informations, consultez le chapitre: PLAQUE DONNÉES ou CARACTÉRISTIQUES TECHNIQUES.

1.4.2 Installation, utilisation et évaluation de la zone

Ce matériel a été fabriqué conformément aux dispositions relatives à la norme harmonisée EN 60974-10/A1:2015 et est considéré comme faisant partie de la "CLASSE A". Cet appareil doit être utilisé exclusivement dans un but professionnel, dans un environnement industriel. Le fabricant n'est pas responsable des dommages causés en cas d'usage domestique.



L'utilisateur, qui doit être un expert dans le domaine, est responsable en tant que tel de l'installation et de l'utilisation de l'appareil selon les instructions du constructeur. Si des perturbations électromagnétiques apparaissent, il est de la responsabilité de l'utilisateur de résoudre le problème en demandant conseil au service après-vente du constructeur.



Dans tous les cas, les perturbations électromagnétiques doivent être réduites de manière à ne plus représenter une gêne.



Avant l'installation de l'appareil, l'utilisateur devra évaluer les problèmes électromagnétiques potentiels qui pourraient survenir aux abords de la zone de travail et en particulier sur la santé des personnes situées à proximité (personnes portant un pacemaker ou un appareil auditif).

1.4.3 Blindage

Le blindage sélectif d'autres câbles et appareils présents à proximité de la zone peut réduire les problèmes d'interférences. Le blindage de toute l'installation de soudage peut être envisagé pour des applications spéciales.

1.5 Degré de protection IP

IP

IP23S

- Boîtier de protection contre l'accès aux parties dangereuses par un doigt et contre des corps solides étrangers ayant un diamètre supérieur/égal à 12.5 mm.
- Grille de protection contre une pluie tombant à 60°.
- Boîtier protégé contre les effets nuisibles dus à la pénétration d'eau lorsque les parties mobiles de l'appareil ne sont pas encore en fonctionnement.

1.6 Liquide de refroidissement

1.6.1 Protection individuelle



Produit nocif par ingestion.
Il peut irriter les yeux, les muqueuses et l'épiderme.



Éviter le contact en mettant des gants en caoutchouc.



Éviter les projections accidentelles en mettant des lunettes de protection.



Éviter le contact avec la peau en portant des vêtements de travail appropriés.

1.6.2 Élimination



Ne pas éliminer les équipements électriques avec les déchets ménagers!

Conformément à la Directive européenne 2012/19/UE relative aux déchets d'équipements électriques et électroniques et à sa mise en œuvre conformément aux lois nationales, les équipements électriques qui ont atteint la fin de leur cycle de vie doivent être collectés séparément et envoyés à un centre de récupération et d'élimination. Le propriétaire de l'équipement doit identifier les centres de collecte agréés en se renseignant auprès des autorités locales. L'application de la Directive Européenne permettra de respecter l'environnement et la santé des êtres humains.



Toutes fuites ou résidus de produit, après utilisation, doivent être traités dans une usine de purification appropriée. Il convient si possible de recycler le produit. Il est interdit de vider le produit usé dans les cours d'eau, dans les fosses ou les systèmes de drainage. Le fluide dilué ne devrait pas être vidé dans les égouts, sauf si cela est admis par la réglementation locale.

2. INSTALLATION

2.1 Mode de soulèvement, de transport et de déchargement

- La machine ne dispose d'aucun élément spécifique pour le levage.



Ne pas sous-évaluer le poids de l'installation, se reporter aux caractéristiques techniques.
Ne pas faire passer ou arrêter la charge suspendue au-dessus de personnes ou d'objets.
Ne pas laisser tomber le matériel ou ne pas créer de pression inutile sur l'appareil.

2.2 Installation de l'appareil



Observer les règles suivantes:

- Réserver un accès facile aux commandes et aux connexions de l'appareil.
 - Ne pas installer l'appareil dans des locaux de petites dimensions.
 - Ne jamais placer la machine sur un plan incliné de plus de 10° par rapport à l'horizontale.
 - Installer le matériel dans un endroit sec, propre et avec une aération appropriée.
 - Mettre l'installation à l'abri de la pluie battante et ne pas l'exposer aux rayons du soleil.
- » Consulter le paragraphe « Prévention dans l'emploi de bouteilles de gaz ».

2.3 Branchement et raccordement



Couper l'alimentation électrique de l'installation avant toute intervention!

2.4 Mise en service

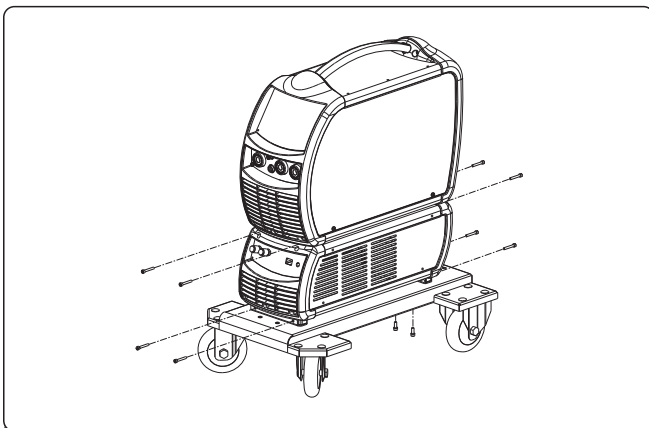

- ▶ Installer le WU sur le GT et le fixer grâce à ses 4 vis.
- ▶ Placer le générateur sur le groupe de refroidissement et le fixer avec les vis correspondantes.

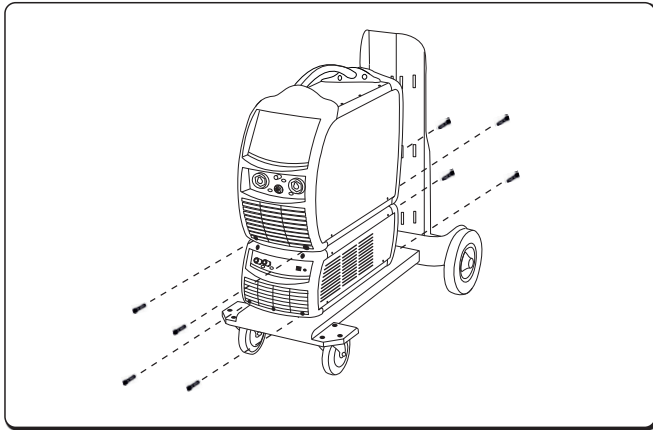

- ▶ Installer le WU sur le GT et le fixer grâce à ses 4 vis.
- ▶ Placer le générateur sur le groupe de refroidissement et le fixer avec les vis correspondantes.

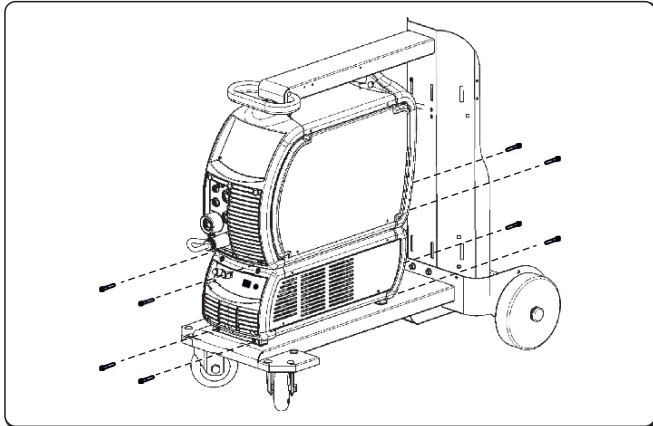

- ▶ Installer le WU sur le GT et le fixer grâce à ses 4 vis.
- ▶ Placer le générateur sur le groupe de refroidissement et le fixer avec les vis correspondantes.

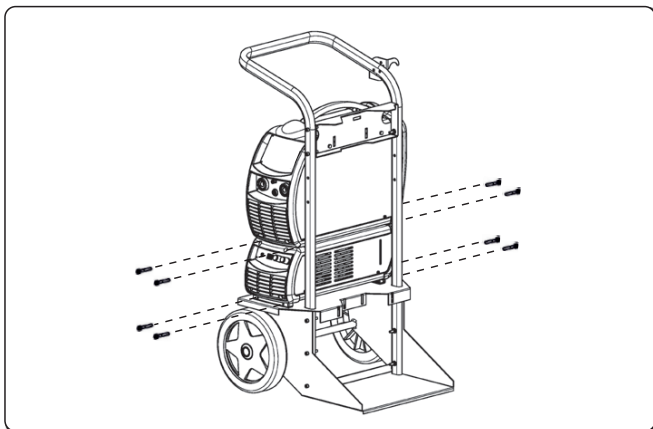

- ▶ Installer le WU sur le GT et le fixer grâce à ses 4 vis.
- ▶ Placer le générateur sur le groupe de refroidissement et le fixer avec les vis correspondantes.



Effectuer les opérations suivantes avant la mise en marche de l'appareil :

- ▶ Enlever le bouchon de fermeture du réservoir.
- ▶ Enlever le bouchon hermétique du goulot en faisant levier sur le bord du bouchon à l'aide d'un outil.
- ▶ Ajouter du liquide dans le réservoir si nécessaire.
- ▶ Conserver le bouchon hermétique pour transporter éventuellement le groupe par la suite.



Toujours monter le tuyau by-pass quand la torche n'est pas branchée aux bornes d'entrée/de sortie du liquide de refroidissement pour ne pas abîmer le groupe de refroidissement.



N'utiliser que du liquide réfrigérant code 18.91.008.

2.4.1 Connexion du panneau arrière

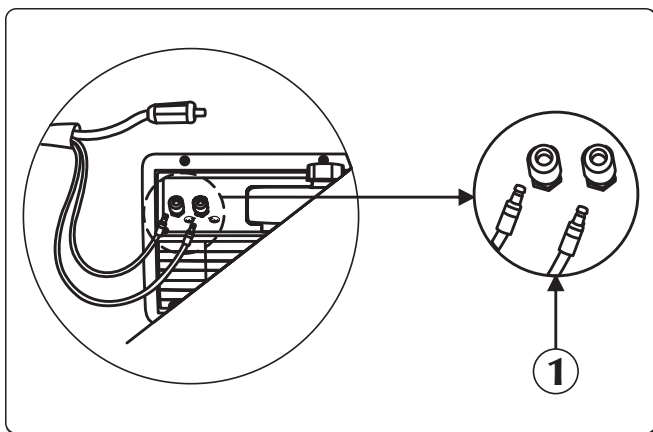

① Entrée/sortie du liquide de refroidissement

- ▶ Relier le tuyau du liquide de refroidissement (symbole bleu) au raccord rapide (symbole bleu) de sortie du refroidisseur.
- ▶ Relier le tuyau du liquide de refroidissement (symbole rouge) au raccord rapide d'entrée (symbole rouge) du refroidisseur.

2.4.2 Connexion du panneau frontal

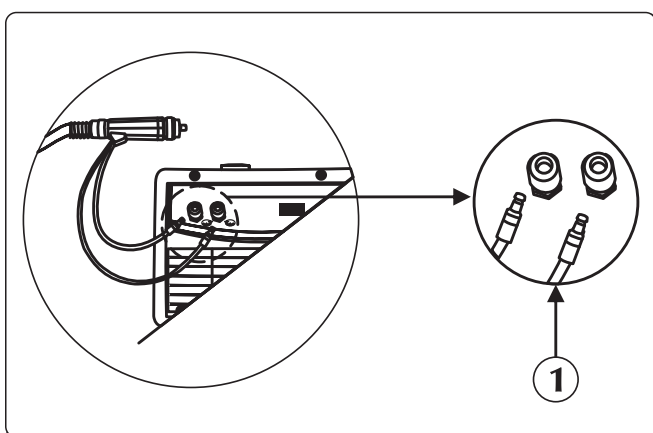

① Entrée/sortie du liquide de refroidissement

- ▶ Relier le tuyau du liquide de refroidissement de la torche (symbole bleu) au raccord rapide (symbole bleu) de sortie du refroidisseur.
- ▶ Relier le tuyau du liquide de refroidissement de la torche (symbole rouge) au raccord rapide d'entrée (symbole rouge) du refroidisseur.

3. PRÉSENTATION DE L'APPAREIL

3.1 Panneau arrière

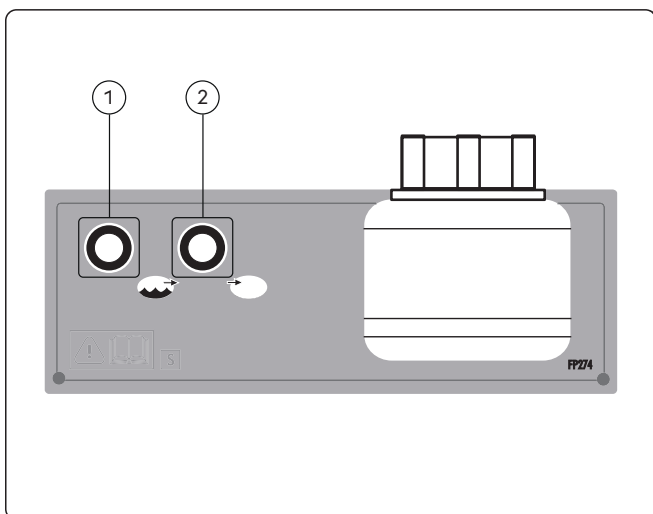

① Raccord de sortie du liquide réfrigérant

Permet d'introduire du liquide à basse température dans le circuit de refroidissement de la torche.

② Raccord d'entrée du liquide réfrigérant

Permet de réintroduire le liquide réchauffé par son passage dans la torche dans le circuit de refroidissement interne du WU.

FR

3.2 Panneau de commande frontal

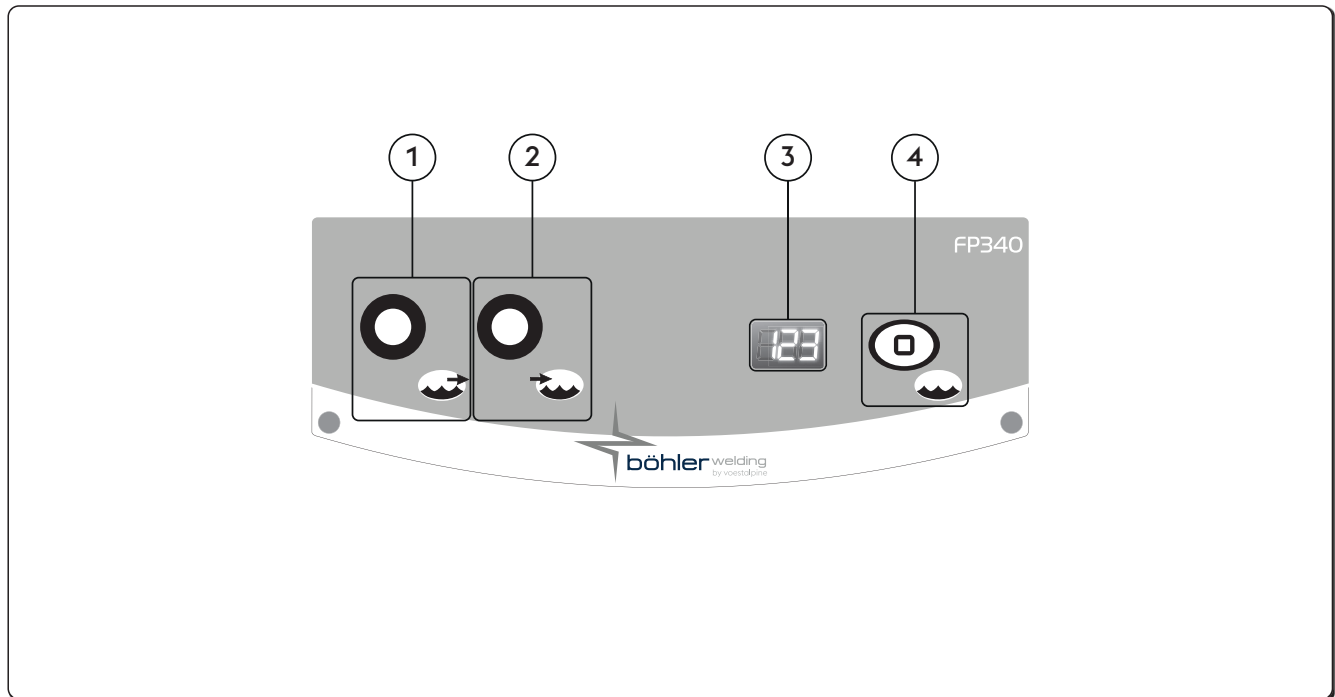

FR

- 1 Raccord de sortie du liquide réfrigérant**
 Permet d'introduire du liquide à basse température dans le circuit de refroidissement de la torche.
- 2 Raccord d'entrée du liquide réfrigérant**
 Permet de réintroduire le liquide réchauffé par son passage dans la torche dans le circuit de refroidissement interne du WU.
- 3 Affichage des données**
 Permet l'affichage des principaux paramètres de WU pendant la période de mise en route (start-up), son fonctionnement correct et la température interne du liquide de refroidissement.
 -- Refroidisseur non disponible.
- 4 Test du refroidisseur**

4. ENTRETIEN

- Effectuer l'entretien courant de l'installation selon les indications du constructeur. Toutes les portes d'accès et de service et les couvercles doivent être fermés et bien fixés lorsque l'appareil est en marche. L'installation ne doit absolument pas être modifiée. Eviter l'accumulation de poussière métallique à proximité et sur les grilles d'aération.
- Toute opération éventuelle de maintenance doit exclusivement être effectuée par du personnel qualifié. La réparation ou le remplacement de pièces de la part de personnel non autorisé implique l'annulation immédiate de la garantie du produit. La réparation ou le remplacement de pièces doit exclusivement être effectué par du personnel technique qualifié.
- Couper l'alimentation électrique de l'installation avant toute intervention!

4.1 Contrôles périodiques sur le générateur

- Contrôler régulièrement le niveau du liquide réfrigérant dans le réservoir. Si le réservoir est complètement vide ou en cas de présence d'air dans la pompe, l'amorçage de cette dernière peut ne pas se produire.
 - Effectuer le nettoyage interne avec de l'air com-primé à basse pression et des brosses souples.
 - Contrôler les connexions électriques et tous les câbles de branchement.
 - Contrôler l'état de la pompe.
 - Contrôler si les raccordements des tuyaux sont effectués correctement.
 Tous les six mois, vidanger le liquide de refroidissement et rincer les tuyaux et le réservoir avec de l'eau. Vidanger le liquide s'il bout, car il perdrait ses propriétés protectrices.



Ne remplir le réservoir de liquide réfrigérant que lorsque le générateur et le groupe WU sont assemblés et posés sur un plan horizontal.



N'utiliser que du liquide réfrigérant code 18.91.008.
Ne jamais utiliser l'équipement sans liquide réfrigérant.



Ne pas utiliser de liquides réfrigérants conducteurs.



Effectuer le nettoyage interne avec de l'air comprimé à basse pression et des brosses souples. Contrôler les connexions électriques et tous les câbles de branchement.

4.2 Responsabilité



Le constructeur décline toute responsabilité si l'opérateur ne respecte pas ces instructions. Le constructeur décline toute responsabilité si l'opérateur ne respecte pas ces instructions. En cas de doute et/ou de problème, n'hésitez pas à consulter le dépanneur agréé le plus proche.

FR

5. CODES D'ALARMES



ALARME















L'intervention d'une alarme ou le dépassement d'un seuil critique de protection entraîne une signalisation visuelle sur le panneau de commande et le blocage immédiat des opérations de soudage.



ATTENTION

Le dépassement d'un seuil de protection entraîne une signalisation visuelle sur le panneau de commande, mais permet de poursuivre les opérations de soudage.

Ci-dessous figure la liste de toutes les alarmes et de tous les seuils critiques de protection du système.

 E43	Liquide de refroidissement manquant		 E71	Surchauffe liquide de refroidissement	
 E76	Niveau de débit du liquide de refroidissement dépassé		 E77	Niveau de température du liquide de refroidissement	
 E81	Surintensité (pompe WU)		 E82	Erreur de communication (WU)	
 E83	Pompe bloquée				

6. DIAGNOSTIC ET SOLUTIONS

Pas de débit d'eau dans le circuit

Cause

- » Manque de liquide dans le réservoir.
- » Air dans le circuit de refroidissement.

Solution

- » Ajouter du liquide.
- » Connecter le faisceau eau raccord rapide à la connexion de sortie (bleue) et purger le système hydraulique pour permettre au liquide de refroidissement de s'échapper pendant quelques secondes.

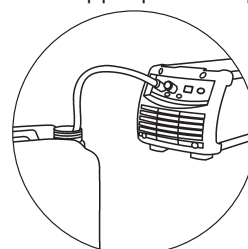

- | | |
|--|--|
| » Circuit de refroidissement bloqué ou défectueux. | » Vérifier l'état des connexions du circuit hydraulique (à l'intérieur de l'appareil).
» Vérifier l'état du circuit hydraulique de la torche.
» Vérifier l'état du circuit de refroidissement dans le faisceau.
» S'adresser service après-vente le plus proche pour la réparation de l'installation. |
| » Présence de l'alarme du refroidisseur. | » Réinitialiser l'alarme.
» Connecter une torche ou le faisceau eau raccord rapide aux modes d'opération nécessitant un refroidisseur actif.
» Vérifier l'état des connexions du circuit hydraulique (à l'intérieur de l'appareil).
» Vérifier l'état du circuit hydraulique de la torche.
» S'adresser service après-vente le plus proche pour la réparation de l'installation. |
| » Pompe défectueuse. | » Remplacer le composant endommagé.
» S'adresser service après-vente le plus proche pour la réparation de l'installation. |







Capacité de refroidissement insuffisante

Cause	Solution
» Ventilateur défectueux.	» Remplacer le composant endommagé. » S'adresser service après-vente le plus proche pour la réparation de l'installation.
» Pompe défectueuse.	» Remplacer le composant endommagé. » S'adresser service après-vente le plus proche pour la réparation de l'installation.

7. CARACTÉRISTIQUES TECHNIQUES





Caractéristiques électriques			U.M.
Tension d'alimentation U1	360		Vdc
Courant maximum absorbé I1max	0.4		A
Puissance de refroidissement (25°C)	1000		W
Caractéristiques physiques			U.M.
Degré de protection IP	IP23S		
Dimensions (lxdxh)	660x240x220		mm
Poids	12.0		Kg
Type d'échangeur	H ₂ O - Air		
Débit nominal (QV)	2.3		l/min
Débit maximal pompe (Qvmax)	4.6		l/min
Hauteur d'élévation pompe (Hmax)	35		m
Type de pompe	Rotative		
Nombre maximal de tours	3300		RPM
Capacité du réservoir	3.0		l
Normes de construction	EN IEC 60974-2:2019 EN 60974-10/A1:2015		

8. PLAQUE DONNÉES

 VOESTALPINE BÖHLER WELDING ARC TECHNOLOGY S.R.L. Via Palladio,19 - ONARA (PADOVA) - ITALY		
WU 2000	N°	
EN IEC	60974-2:2019 60974-10/A1:2015 Class A	
Energy input		
	U₁ 350V	I_{1max} 0.35A
	IP 23 S	
Liquid cooling system		
	P_{11/min} 1.0kW	P_{max} 0.35MPa (3.5bar)
		  
		MADE IN ITALY 

FR

9. SIGNIFICATION DE LA PLAQUE DES DONNÉES

1		2	
3		4	
5			
6			
6	7	8	
	9		
10			
10	11	12	
		  	
		MADE IN ITALY 	

- 1 Marque de fabrique
- 2 Nom et adresse du constructeur
- 3 Modèle de l'appareil
- 4 N° de série
XXXXXXXXXXXX Année de fabrication
- 5 Référence aux normes de construction
- 6 Symbole pour l'alimentation
- 7 Tension nominale d'alimentation
- 8 Courant maximum nominal d'alimentation
- 9 Degré de protection
- 10 Symbole de refroidissement
- 11 Puissance de refroidissement
- 12 Pression maximum

CE Déclaration de conformité UE
 EAC Déclaration de conformité EAC
 UKCA Déclaration de conformité UKCA

DECLARACIÓN UE DE CONFORMIDAD

El constructor
voestalpine Böhler Welding Arc Technology S.r.l.
Via Palladio, 19 - 35019 Onara di Tombolo (PD) - ITALY
Tel. +39 049 9413/111 - Fax +39 049 9413/311 - www.voestalpine.com/welding

declara bajo su exclusiva responsabilidad que el siguiente producto:

WU 2000 **71.03.076**

es conforme a las directivas EU:

2014/35/EU **LOW VOLTAGE DIRECTIVE**

2014/30/EU **EMC DIRECTIVE**

2011/65/EU **RoHS DIRECTIVE**

y que se han aplicado las siguientes normas armonizadas:

EN IEC 60974-2:2019 **LIQUID COOLING SYSTEMS**

EN 60974-10/A1:2015 **ELECTROMAGNETIC COMPATIBILITY REQUIREMENTS**

La documentación que acredite el cumplimiento de las directivas se mantendrá disponible para inspecciones en el mencionado fabricante.

Toda reparación, o modificación, no autorizada por voestalpine Böhler Welding Arc Technology S.r.l. hará decaer la validez e invalidará esta declaración.

Onara di Tombolo, 01/05/2025

voestalpine Böhler Welding Arc Technology S.r.l.



Mirco Frasson **Ivo Bonello**

Managing Directors

INDICE

1. ADVERTENCIA	55
1.1 Entorno de utilización	55
1.2 Protección personal y de terceros	55
1.3 Protección contra descargas eléctricas	56
1.4 Campos electromagnéticos y interferencias	56
1.5 Grado de protección IP	56
1.6 Líquido de refrigeración	56
2. INSTALACIÓN	57
2.1 Elevación, transporte y descarga	57
2.2 Colocación del equipo	57
2.3 Conexión	57
2.4 Instalación	57
3. PRESENTACIÓN DEL SISTEMA	59
3.1 Panel posterior	59
3.2 Panel de mandos frontal	60
4. MANTENIMIENTO	60
4.1 Controles periódicos de la fuente de alimentación	60
4.2 Responsabilidad	61
5. CODIFICACIÓN DE ALARMAS	61
6. DIAGNÓSTICO Y SOLUCIÓN DE PROBLEMAS	61
7. CARACTERÍSTICAS TÉCNICAS	62
8. PLACA DE DATOS	63
9. SIGNIFICADO DE LA ETIQUETA DE LOS DATOS	63
10. ESQUEMA	149
11. CONECTORES	150
12. LISTA DE REPUESTOS	151

ES

SÍMBOLOS



Advertencia



Prohibiciones



Obligaciones



Indicaciones generales

1. ADVERTENCIA



Antes de comenzar cualquier tipo de operación, tiene que haber comprendido el contenido del presente manual. No efectúe modificaciones ni mantenimientos no descritos en este manual. El fabricante no es responsable por daños a personas o cosas causados por una lectura, o una puesta en aplicación negligente de cuanto escrito del contenido de este manual.

El manual de instrucciones debe permanecer guardado en el lugar de empleo del equipo. Complementariamente al manual de instrucciones, se deben tener en cuenta las reglas válidas a modo general, así como las reglas locales respecto a la prevención de accidentes y la protección medioambiental.

voestalpine Böhler Welding Arc Technology S.r.l. se reserva el derecho de efectuar modificaciones en cualquier momento y sin aviso previo.

Reservados todos los derechos de traducción, reproducción y adaptación total o parcial con cualquier medio (incluidas las copias foto-estáticas, películas y microfilms), sin la autorización escrita por parte de voestalpine Böhler Welding Arc Technology S.r.l.

Los temas tratados en este manual son de vital importancia, y por tanto imprescindibles para poder aplicar las garantías.

Si el operador no se atiende a lo descrito, el fabricante declina cualquier tipo de responsabilidad.



Todas las personas implicadas en la puesta en servicio, el manejo, el mantenimiento y la conservación del equipo deben:

- poseer la cualificación correspondiente
- Leer completamente y seguir escrupulosamente este manual de instrucciones

En caso de dudas o problemas sobre la utilización del equipo, aunque no se indiquen aquí, consulte con personal cualificado.

1.1 Entorno de utilización



El equipo debe utilizarse exclusivamente para las operaciones para las cuales ha sido diseñado, en los modos y dentro de los campos previstos en la placa de identificación y/o en este manual, según las directivas nacionales e internacionales sobre la seguridad. Un uso diferente del declarado por el fabricante se considera inadecuado y peligroso; en dicho caso, el fabricante no asumirá ninguna responsabilidad.



Este equipo tiene que debe utilizarse sólo para fines profesionales en un local industrial. El fabricante no responde de daños provocados por un uso del equipo en entornos domésticos.



El equipo debe utilizarse en locales con una temperatura comprendida entre -10°C y +40°C (entre +14°F y +104°F).

El equipo debe transportarse y almacenarse en locales con una temperatura comprendida entre -25°C y +55°C (entre -13°F y 131°F).

El equipo debe utilizarse en locales sin polvo, ácidos, gases ni otras sustancias corrosivas.

El equipo debe utilizarse en locales con una humedad relativa no superior al 50% a 40°C (104°F).

El equipo debe utilizarse en locales con una humedad relativa no superior al 90% a 20°C (68°F).

El equipo debe utilizarse a una altitud máxima sobre el nivel del mar de 2000 m (6500 pies).

1.2 Protección personal y de terceros



Compruebe que la antorcha se haya enfriado antes de efectuar trabajos o mantenimientos.



Compruebe que el grupo de refrigeración esté apagado antes de desconectar los tubos de suministro y de retorno del líquido refrigerante. El líquido caliente que sale podría provocar graves quemaduras.



Tenga a mano un equipo de primeros auxilios.
No subestime quemaduras o heridas.



Antes de abandonar el puesto de trabajo, tome todas las medidas de seguridad para dejar la zona de trabajo segura y así impedir accidentes graves a personas o bienes.

1.3 Protección contra descargas eléctricas



Las descargas eléctricas suponen un peligro de muerte.

- No toque las piezas internas ni externas bajo tensión del equipo de soldadura mientras el equipo éste se encuentre activado (antorchas, pinzas, cables de masa, electrodos, alambres, rodillos y bobinas están conectados eléctricamente al circuito de soldadura).
- Compruebe el aislamiento eléctrico del equipo, utilizando superficies y bases secas y aisladas perfectamente del potencia de tierra y de masa de la tierra.

1.4 Campos electromagnéticos y interferencias

1.4.1 Clasificación EMC in acuerdo con la Normativa: EN 60974-10/A1:2015.



Le matériel de classe B est conforme aux exigences de compatibilité électromagnétique en milieu industriel et résidentiel, y compris en environnement résidentiel où l'alimentation électrique est distribuée par un réseau public basse tension.



Le matériel de classe A n'est pas conçu pour être utilisé en environnement résidentiel où l'alimentation électrique est distribuée par un réseau public basse tension. Puede ser potencialmente difícil asegurar la compatibilidad electromagnética de los dispositivos de clase A en estas áreas, a causa de las perturbaciones irradiadas y conducidas.

Para más información, consulte el capítulo: PLACA DE DATOS o CARACTERÍSTICAS TÉCNICAS.

1.4.2 Instalación, uso y evaluación del área

Este equipo responde a las indicaciones especificaciones de la norma armonizada EN 60974-10/A1:2015 y se identifica como de "CLASEA". Este equipo tiene que debe utilizarse sólo para fines profesionales en un local industrial. El fabricante no responde de daños provocados por un uso del equipo en entornos domésticos.



El usuario debe ser un experto del sector y como tal es responsable de la instalación y del uso del aparato según las indicaciones del fabricante. Si se detectasen perturbaciones electromagnéticas, el usuario del equipo tendrá que resolver la situación sirviéndose de la asistencia técnica del fabricante.



Debe procurar reducir las perturbaciones electromagnéticas hasta un nivel que no resulte molesto.



Antes de instalar este equipo, el usuario tiene que evaluar los potenciales problemas electro-magnéticos que podrían producirse en la zona circundante y, en particular, la salud de las personas expuestas, por ejemplo: personas con marcapasos y aparatos acústicos.

1.4.3 Blindaje

El blindaje selectivo de otros cables y aparatos presentes en la zona circundante puede reducir los problemas de interferencia. En caso de aplicaciones especiales, también puede considerarse el blindaje de todo el equipo de soldadura.

1.5 Grado de protección IP



IP23S

- Para evitar el contacto de los dedos con partes peligrosas y la entrada de cuerpos sólidos extraños de diámetro mayor/igual a 12.5 mm.
- Envoltura protegida contra la lluvia a 60° sobre la vertical.
- Envoltura protegida contra los efectos perjudiciales debidos a la entrada de agua, cuando las partes móviles del aparato no están en movimiento.

1.6 Líquido de refrigeración

1.6.1 Protección personal



Producto nocivo por ingestión.
Puede provocar irritación en los ojos, las mucosas y la piel.



Evite el contacto utilizando guantes de goma.



Evite las salpicaduras accidentales utilizando gafas de seguridad.



Evite el contacto con la piel utilizando vestimenta laboral.

1.6.2 Eliminación



¡No arroje nunca el equipo eléctrico entre los residuos comunes!

Con arreglo a la Directiva Europea 2012/19/UE sobre Residuos de Aparatos Eléctricos y Electrónicos y su implementación de acuerdo con las leyes nacionales, los aparatos eléctricos que hayan llegado al final de su ciclo de vida deben recogerse por separado y enviarse a un centro de recuperación y eliminación. El propietario del aparato debe identificar los centros de recogida autorizados consultando con las Administraciones Locales. La aplicación de la Directiva Europea permitirá mejorar el medio ambiente y la salud humana.



Las pérdidas o los residuos del producto, después de haberlo empleado para su utilización habitual, deben ser tratarse en una instalación de depuración adecuada o, a ser posible, debe reciclarse el producto. No está permitido desechar el producto usado en cursos de agua, pozos o sistemas de desagüe. El fluido diluido no debe vaciarse en las alcantarillas, salvo en los casos en que esté permitido por las normativas locales.

2. INSTALACIÓN

2.1 Elevación, transporte y descarga

- El equipo no incorpora elementos específicos para la elevación.



No subestime el peso del equipo, consulte las características técnicas.

No traslade ni detenga la carga encima de personas u objetos.

No aplique una presión excesiva sobre el equipo.

2.2 Colocación del equipo



Observe las siguientes normas:

- El acceso a los mandos y conexiones tiene que ser fácil.
 - No coloque el equipo en lugares estrechos.
 - No coloque nunca el equipo sobre una superficie con una inclinación superior a 10° respecto del plano horizontal.
 - Coloque el equipo en un lugar seco, limpio y con ventilación apropiada.
 - Proteja la instalación de la lluvia y del sol.
- » Consulte la sección "Prevención durante el uso de las botellas de gas".

2.3 Conexión



¡Antes de cada operación, desconecte el equipo!

2.4 Instalación

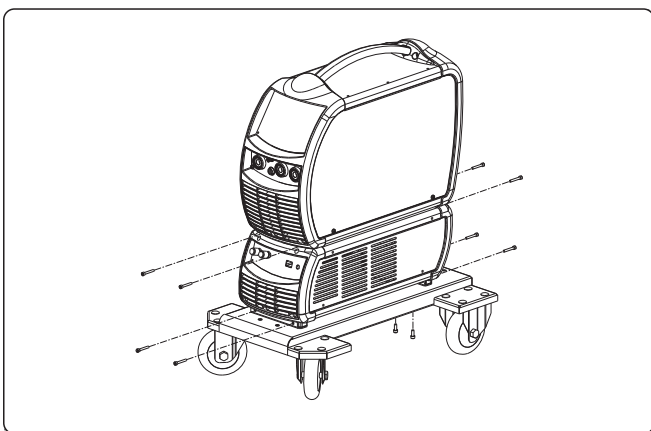

- ▶ Coloque WU sobre GT y fíjelo con los 4 tornillos respectivos.
- ▶ Coloque la fuente de alimentación encima del grupo de refrigeración y fíjelo con los tornillos respectivos.

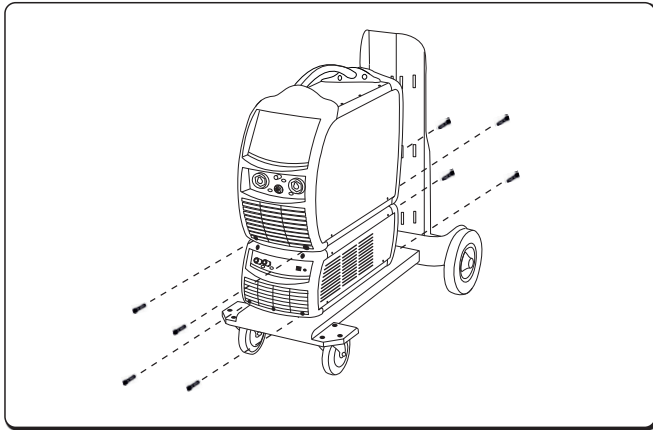

- ▶ Coloque WU sobre GT y fíjelo con los 4 tornillos respectivos.
- ▶ Coloque la fuente de alimentación encima del grupo de refrigeración y fíjelo con los tornillos respectivos.

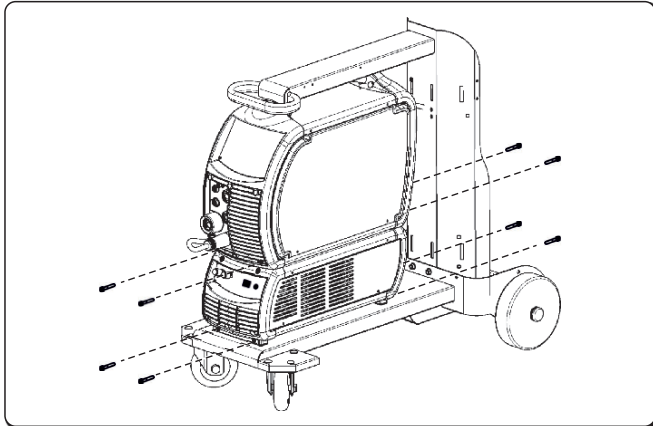

- ▶ Coloque WU sobre GT y fíjelo con los 4 tornillos respectivos.
- ▶ Coloque la fuente de alimentación encima del grupo de refrigeración y fíjelo con los tornillos respectivos.

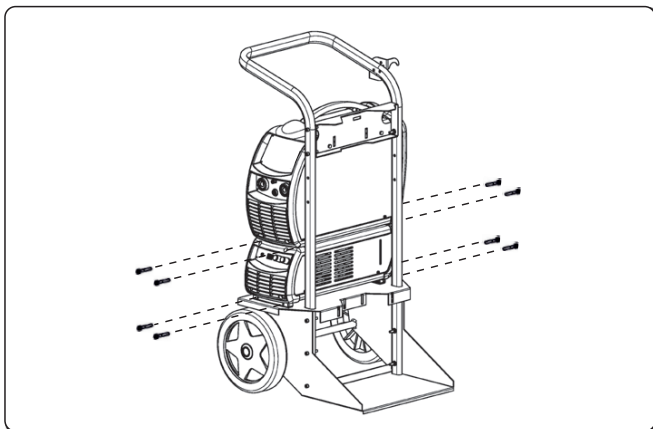

- ▶ Coloque WU sobre GT y fíjelo con los 4 tornillos respectivos.
- ▶ Coloque la fuente de alimentación encima del grupo de refrigeración y fíjelo con los tornillos respectivos.



Antes de poner en funcionamiento el grupo realice las siguientes operaciones:

- ▶ Retire el tapón de cierre del tanque.
- ▶ Retire el tapón hermético del canal de entrada, haciendo palanca con un utensilio en el borde del tapón.
- ▶ Si es necesario, añada refrigerante dentro al tanque.
- ▶ Guarde el tapón hermético para eventuales transportes futuros del grupo.



Para no dañar el grupo de refrigeración, conecte siempre el tubo by-pass cuando la antorcha no esté conectada a los terminales de entrada/salida del líquido refrigerante.



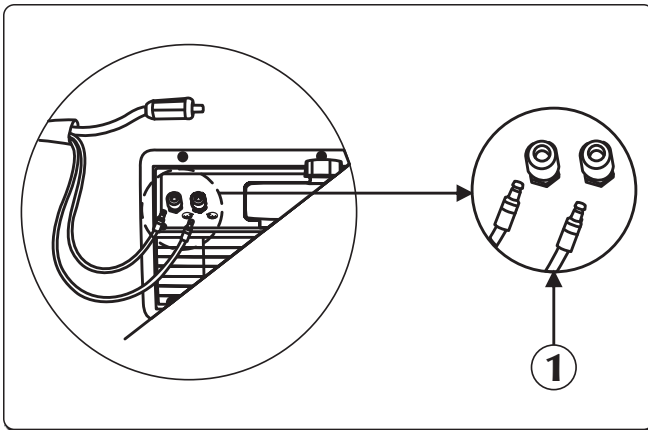

Para llenar el depósito utilice líquido refrigerante cód. 18.91.008.

2.4.1 Conexión panel trasero





① Entrada/salida del líquido de refrigeración

- ▶ Conecte el tubo de alimentación del líquido refrigerante agua del haz de cables (color azul) al conector de salida de la unidad de refrigeración (color azul - símbolo ).
- ▶ Conecte el tubo de retorno del líquido refrigerante agua del haz de cables (color rojo) al conector de entrada de la unidad de refrigeración (color rojo - símbolo ).

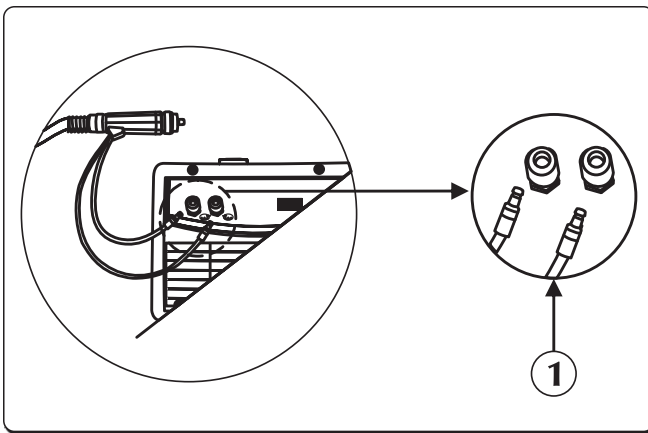
2.4.2 Conexión panel frontal



① Entrada/salida del líquido de refrigeración

- ▶ Conecte el tubo de alimentación del líquido refrigerante agua de color azul de la antorcha al conector de salida de la unidad de refrigeración (color azul - símbolo ).
- ▶ Conecte el tubo de retorno del líquido refrigerante agua de color rojo de la antorcha al conector de entrada de la unidad de refrigeración (color rojo - símbolo ).

3. PRESENTACIÓN DEL SISTEMA

3.1 Panel posterior

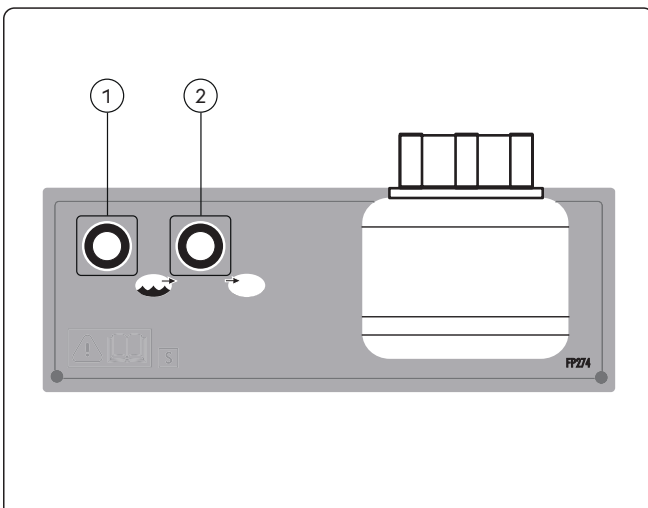

① Racor de salida del líquido refrigerante

Permite introducir líquido a baja temperatura en el circuito de refrigeración de la antorcha.

② Racor de entrada del líquido refrigerante

Permite introducir el líquido, calentado por la antorcha, en el circuito de refrigeración interior del WU.

3.2 Panel de mandos frontal

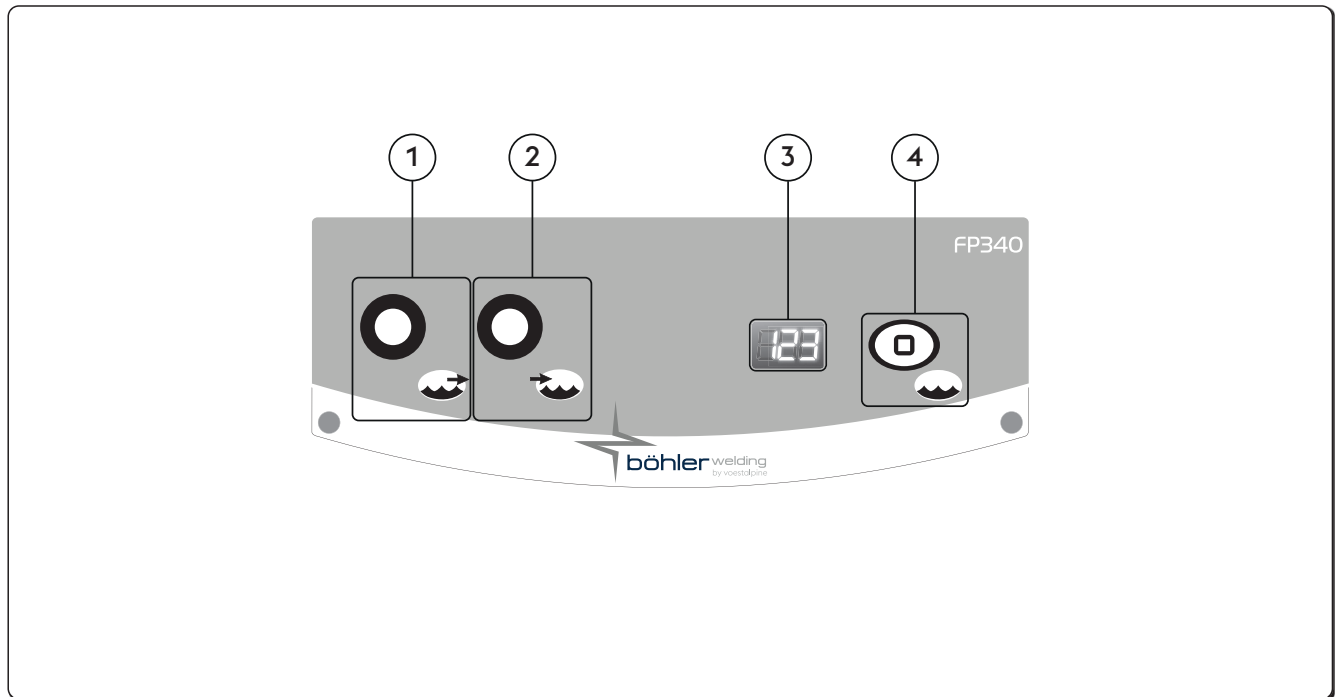

ES

- 1 Racor de salida del líquido refrigerante**
 Permite introducir líquido a baja temperatura en el circuito de refrigeración de la antorcha.
- 2 Racor de entrada del líquido refrigerante**
 Permite introducir el líquido, calentado por la antorcha, en el circuito de refrigeración interior del WU.
- 3 Pantalla de 7 segmentos**
 Permite visualizar las generalidades de la WU en fase de salida, su funcionamiento correcto y la temperatura interna del líquido refrigerante.
 -- Grupo de refrigeración desactivado.
- 4 Test grupo de refrigeración**

4. MANTENIMIENTO

- Efectúe el mantenimiento ordinario del equipo según las indicaciones del fabricante. Cuando el equipo esté funcionando, todas las puertas de acceso y de servicio y las tapas tienen que estar cerradas y fijadas perfectamente. El equipo no debe ser modificado. Procure que no se forme polvo metálico en proximidad y cerca o encima de las aletas de ventilación.
- El mantenimiento debe efectuarlo personal cualificado. La reparación o la sustitución de componentes del sistema por parte de personal no autorizado provoca la caducidad inmediata de la garantía del producto. La reparación o sustitución de componentes del equipo debe ser hecha realizarla personal técnico cualificado.

¡Antes de cada operación, desconecte el equipo!

4.1 Controles periódicos de la fuente de alimentación

Periódicamente, controle el nivel del líquido refrigerante en el depósito. Si el depósito quedara completamente vacío, o si entrara aire en la bomba, la misma ésta podría no arrancar.

- Limpie el interior con aire comprimido a baja presión y con pinceles de cerdas suaves.
- Controle las conexiones eléctricas y todos los cables de conexión.
- Controle el estado de la electrobomba.
- Controle el estado de las conexiones de los tubos.

Cada seis meses, cambie el líquido refrigerante y enjuague los tubos y el tanque con agua. Cambie el líquido si hierve, porque perdería sus propiedades metálicas de protección.



El llenado del depósito con líquido refrigerante se debe realizar con la fuente de alimentación y WU montados y colocados sobre una superficie horizontal.



Para llenar el depósito utilice líquido refrigerante cód. 18.91.008. Se prohíbe utilizar el equipo sin el líquido refrigerante.



No utilice líquidos refrigerantes conductivos.



Limpie el interior con aire comprimido a baja presión y con pinceles de cerdas suaves. Compruebe las conexiones eléctricas y todos los cables de conexión.

4.2 Responsabilidad



La carencia de este mantenimiento, provocará la caducidad de todas las garantías y el fabricante se considerará exento de toda responsabilidad. Si el operador no respetara las instrucciones descritas, el fabricante declina cualquier responsabilidad. Si tuviera dudas y/o problemas no dude en consultar al centro de asistencia técnica más cercano.

5. CODIFICACIÓN DE ALARMAS



ALARMA















La activación de una alarma o la superación de un límite de seguridad crítico provoca una señal visual en el panel de mandos y el bloqueo inmediato de las operaciones de soldadura.



ATENCIÓN

Si se supera un límite de protección, se activa una señal visual en el panel de mandos, pero es posible continuar con las operaciones de soldadura.

A continuación se enumeran todas las alarmas y todos los límites de protección relativos al sistema.

 E43	Falta líquido refrigerante		 E71	Sobretemperatura líquido refrigerante	
 E76	Superado el nivel de flujo líquido refrigerante		 E77	Nivel de temperatura líquido refrigerante	
 E81	Sobrecorriente (bomba WU)		 E82	Error de comunicación (WU)	
 E83	Bomba bloqueada				

6. DIAGNÓSTICO Y SOLUCIÓN DE PROBLEMAS

Falta de flujo en el circuito

Causa

- » Falta de líquido en el depósito.
- » Aire en el circuito de refrigeración.

Solución

- » Rellene el depósito.
- » Inserte el bypass en la unión de salida (color azul) y ventile el circuito hidráulico permitiendo la salida del líquido refrigerante durante algunos segundos.

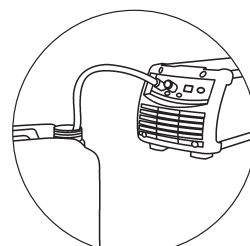

- | | |
|--|---|
| » Circuito de refrigeración atascado o interrumpido. | » Compruebe el estado de las conexiones (internas al grupo) del circuito hidráulico.
» Compruebe el estado del circuito hidráulico de la antorcha.
» Compruebe el estado del circuito hidráulico del conjunto de cables.
» Contacte con el centro de asistencia más cercano para la reparación del sistema. |
| » Presencia de la alarma del grupo de refrigeración. | » Reiniciar la alarma.
» Conecte una antorcha o el bypass en los modos de funcionamiento que prevén el grupo de refrigeración en actividad.
» Compruebe el estado de las conexiones (internas al grupo) del circuito hidráulico.
» Compruebe el estado del circuito hidráulico de la antorcha.
» Contacte con el centro de asistencia más cercano para la reparación del sistema. |
| » Bomba averiada. | » Sustituya el componente averiado.
» Contacte con el centro de asistencia más cercano para la reparación del sistema. |







Capacidad insuficiente de refrigeración

Causa	Solución
» Ventilador averiado.	» Sustituya el componente averiado. » Contacte con el centro de asistencia más cercano para la reparación del sistema.
» Bomba averiada.	» Sustituya el componente averiado. » Contacte con el centro de asistencia más cercano para la reparación del sistema.

7. CARACTERÍSTICAS TÉCNICAS





Características eléctricas			U.M.
Tensión de alimentación U1	360		Vdc
Corriente máxima absorbida I1max	0.4		A
Potencia de refrigeración (25°C)	1000		W
Características físicas			U.M.
Grado de protección IP	IP23S		
Dimensiones (lxwxh)	660x240x220		mm
Peso	12.0		Kg
Tipo de intercambiador	H ₂ O - Aire		
Capacidad nominal (QV)	2.3		l/min
Capacidad máxima bomba (Qvmax)	4.6		l/min
Altura de elevación bomba (Hmax)	35		m
Tipo de bomba	Centrífuga		
Nº de revoluciones máximo	3300		RPM
Capacidad del tanque	3.0		l
Normas de fabricación	EN IEC 60974-2:2019 EN 60974-10/A1:2015		

8. PLACA DE DATOS

 VOESTALPINE BÖHLER WELDING ARC TECHNOLOGY S.R.L. Via Palladio, 19 - ONARA (PADOVA) - ITALY		
WU 2000	N°	
EN IEC	60974-2:2019 60974-10/A1:2015 Class A	
Energy input		
	U₁ 350V	I_{1max} 0.35A
	IP 23 S	
Liquid cooling system		
	P_{11/min} 1.0kW	P_{max} 0.35MPa (3.5bar)
		  
	MADE IN ITALY	

ES

9. SIGNIFICADO DE LA ETIQUETA DE LOS DATOS

1		2	
3		4	
5			
6			
6	7	8	
	9		
10			
10	11	12	
		  	
	MADE IN ITALY		

- 1 Marca de fabricación
- 2 Nombre y dirección del fabricante
- 3 Modelo del aparato
- 4 N° de serie
 XXXXXXXXXXXX Año de fabricación
- 5 Referencia a las normas de construcción
- 6 Símbolo de la alimentación
- 7 Tensión asignada de alimentación
- 8 Máxima corriente asignada de alimentación
- 9 Grado de protección
- 10 Símbolo del sistema de refrigeración
- 11 Potencia de refrigeración
- 12 Presión máxima

CE Declaración UE de conformidad
 EAC Declaración de conformidad EAC
 UKCA Declaración de conformidad UKCA

DECLARAÇÃO DE CONFORMIDADE CE

O construtor
voestalpine Böhler Welding Arc Technology S.r.l.
Via Palladio, 19 - 35019 Onara di Tombolo (PD) - ITALY
Tel. +39 049 9413/111 - Fax +39 049 9413/311 - www.voestalpine.com/welding

declara sob sua exclusiva responsabilidade que o seguinte produto:

WU 2000 **71.03.076**

está conforme as directivas UE:

2014/35/UE **LOW VOLTAGE DIRECTIVE**

2014/30/UE **EMC DIRECTIVE**

2011/65/UE **RoHS DIRECTIVE**

e que as seguintes normas harmonizadas foram aplicadas:

EN IEC 60974-2:2019

LIQUID COOLING SYSTEMS

EN 60974-10/A1:2015

ELECTROMAGNETIC COMPATIBILITY REQUIREMENTS

A documentação que atesta o cumprimento das diretrizes ficará à disposição para vistorias no referido fabricante.

Qualquer operação ou modificação não autorizada, previamente, pela voestalpine Böhler Welding Arc Technology S.r.l. anulará a validade desta declaração.

Onara di Tombolo, 01/05/2025

voestalpine Böhler Welding Arc Technology S.r.l.



Mirco Frasson

Ivo Bonello

Managing Directors

ÍNDICE GERAL

1. ATENÇÃO	67
1.1 Condições de utilização.....	67
1.2 Protecção do operador e de outros indivíduos	67
1.3 Protecção contra choques eléctricos.....	68
1.4 Campos electromagnéticos e interferências	68
1.5 Grau de protecção IP	68
1.6 Líquido de refrigeração.....	68
2. INSTALAÇÃO.....	69
2.1 Elevação, transporte e descarga	69
2.2 Posicionamento do equipamento.....	69
2.3 Ligações.....	69
2.4 Instalação.....	69
3. APRESENTAÇÃO DO SISTEMA	71
3.1 Painel traseiro.....	71
3.2 Painel de comandos frontal.....	72
4. MANUTENÇÃO.....	72
4.1 Efectuar periodicamente as seguintes operações.....	72
4.2 Ansvr	73
5. CÓDIGOS DE ALARME.....	73
6. RESOLUÇÃO DE PROBLEMAS.....	73
7. CARACTERÍSTICAS TÉCNICAS.....	74
8. PLACA DE DADOS	75
9. SIGNIFICADO DA PLACA DE DADOS	75
10. DIAGRAMA	149
11. CONECTORES.....	150
12. LISTA DE PEÇAS DE REPOSIÇÃO	151

PT

SIMBOLOS



Atenção



Proibições



Obrigações



Indicações gerais

1. ATENÇÃO



Antes de iniciar qualquer tipo de operação na máquina, é necessário ler cuidadosamente e compreender o conteúdo deste manual.

Não efectuar modificações ou operações de manutenção que não estejam previstas. O fabricante não se responsabiliza por danos causados em pessoas ou bens, resultantes da utilização incorrecta ou da não-aplicação do conteúdo deste manual.

Manter sempre as instruções de utilização no local de utilização do aparelho. Para além das instruções de utilização, observar as normas gerais e os regulamentos locais de prevenção de acidentes e protecção ambiental em vigor.

A voestalpine Böhler Welding Arc Technology S.r.l. tem o direito de modificar o conteúdo deste manual em qualquer altura, sem aviso prévio.

São reservados todos os direitos de tradução, reprodução e adaptação parcial ou total, seja por que meio for (incluindo fotocópia, filme e microfilme) e é proibida a reprodução sem autorização prévia, por escrito, da voestalpine Böhler Welding Arc Technology S.r.l.

O exposto neste manual é de importância vital e, portanto, necessário para assegurar as garantias.

Caso o operador não respeite o prescrito, o fabricante declina toda e qualquer responsabilidade.



Todas as pessoas envolvidas na colocação em serviço, utilização, manutenção e reparação do aparelho devem:

- ser titulares de qualificação apropriada
- e integralmente e respeitar rigorosamente estas instruções de utilização

Para quaisquer dúvidas ou problemas relativos à utilização do equipamento, ainda que não se encontrem aqui descritos, consultar pessoal qualificado.

1.1 Condições de utilização



Cada instalação deve ser utilizada exclusivamente para as operações para que foi projectada, nos modos e nos âmbitos previstos na chapa de características e/ou neste manual, de acordo com as directivas nacionais e internacionais relativas à segurança. Uma utilização diferente da expressamente declarada pelo construtor deve ser considerada completamente inadequada e perigosa e, neste caso, o construtor declina toda e qualquer responsabilidade.



Esta máquina só deve ser utilizada com fins profissionais, numa instalação industrial. O construtor declina qualquer responsabilidade por eventuais danos provocados pela utilização da instalação em ambientes domésticos.



O equipamento deve ser utilizado em ambientes cujas temperaturas estejam compreendidas entre -10°C e +40°C (entre +14°F e +104°F).

O equipamento deve ser transportado e armazenado em ambientes cujas temperaturas estejam compreendidas entre -25°C e +55°C (entre -13°F e 131°F).

O equipamento deve ser utilizado em ambientes sem poeira, ácidos, gases ou outras substâncias corrosivas.

O equipamento deve ser utilizado em ambientes com humidade relativa não superior a 50%, a 40°C (104°F).

O equipamento deve ser utilizado em ambientes com humidade relativa não superior a 90%, a 20°C (68°F).

O equipamento deve ser utilizado a uma altitude máxima, acima do nível do mar, não superior a 2000 m (6500 pés).

1.2 Protecção do operador e de outros indivíduos



Verificar se a tocha arrefeceu antes de executar trabalhos ou operações de manutenção.



Assegurar que o grupo de refrigeração é desactivado, antes de desligar os tubos de alimentação e retorno do líquido de refrigeração. O líquido quente em saída pode provocar queimaduras graves.



Manter perto de si um estojo de primeiros socorros, pronto a utilizar.
Não subestimar qualquer queimadura ou ferida.



Antes de abandonar o posto de trabalho, deixar a área de trabalho em boas condições de segurança, de maneira a evitar danos materiais e pessoais acidentais.

1.3 Protecção contra choques eléctricos



Um choque de descarga eléctrica pode ser mortal.

- Evitar tocar nas zonas normalmente sob tensão, no interior ou no exterior da máquina de soldar, enquanto a própria instalação estiver alimentada (tochas, pistolas, cabos de terra, fios, rolos e bobinas estão electricamente ligados ao circuito de soldadura).
- Efectuar o isolamento eléctrico da instalação e do operador, utilizando planos e bases secos e suficientemente isolados da terra.

1.4 Campos electromagnéticos e interferências

1.4.1 Classificação CEM em conformidade com a norma: EN 60974-10/A1:2015.

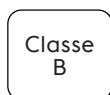

O equipamento Classe B cumpre os requisitos de compatibilidade electromagnética em ambientes industriais e residenciais, incluindo zonas residenciais em que o fornecimento de energia eléctrica é efectuado pela rede pública de baixa tensão.

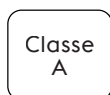

O equipamento Classe A não deve ser utilizado em zonas residenciais em que o fornecimento de energia eléctrica é efectuado pela rede pública de baixa tensão. Dado que eventuais perturbações de condutividade e radiação poderão dificultar a compatibilidade electromagnética do equipamento classe A nessas zonas.

Para mais informações, consulte o capítulo: PLACA DE DADOS ou Características técnicas.

1.4.2 Instalação, utilização e estudo da área

Este equipamento foi construído em conformidade com as indicações contidas na norma harmonizada EN 60974-10/A1:2015 e está identificado como pertencente à "CLASSE A". Esta máquina só deve ser utilizada com fins profissionais, numa instalação industrial. O construtor declina qualquer responsabilidade por eventuais danos provocados pela utilização da instalação em ambientes domésticos.



O utilizador deve ser especializado na actividade, sendo, por isso, responsável pela instalação e pela utilização do equipamento de acordo com as indicações do fabricante. Caso se detectem perturbações electromagnéticas, o operador do equipamento terá de resolver o problema, se necessário em conjunto com a assistência técnica do fabricante.



As perturbações electromagnéticas têm sempre que ser reduzidas até deixarem de constituir um problema.



Antes de instalar este equipamento, o utilizador deverá avaliar potenciais problemas electromagnéticos que poderão ocorrer nas zonas circundantes e, particularmente, os relativos às condições de saúde das pessoas expostas, por exemplo, das pessoas que possuam "pacemakers" ou aparelhos auditivos.

1.4.3 Blindagem

A blindagem selectiva de outros cabos e equipamentos presentes na zona circundante pode reduzir os problemas provocados por interferência electromagnética.

A blindagem de toda a máquina de soldar pode ser ponderada para aplicações especiais.

1.5 Grau de protecção IP



IP23S

- Invólucro protegido contra o acesso de dedos a partes perigosas e contra objectos sólidos com diâmetro superior/ igual a 12,5 mm.
- Invólucro protegido contra chuva que caia num ângulo até 60°.
- Invólucro protegido contra os efeitos danosos devidos à entrada de água, quando as partes móveis do equipamento não estão em movimento.

1.6 Líquido de refrigeração

1.6.1 Protecção pessoal



Produto nocivo por ingestão.
Pode provocar irritação nos olhos, nas mucosas e na pele.



Evitar o contacto utilizando luvas de borracha.



Evitar os salpicos acidentais utilizando óculos de segurança.



Evitar o contacto com a pele utilizando vestuário de trabalho normal.

1.6.2 Descarte



Não eliminar o equipamento elétrico juntamente com o lixo comum!

Em conformidade com a Diretiva Europeia 2012/19/UE relativa aos Resíduos de Equipamentos Elétricos e Eletrónicos e a sua aplicação de acordo com a legislação nacional, os equipamentos elétricos que tenham atingido o fim do seu ciclo de vida devem ser recolhidos separadamente e enviados para um centro de valorização e eliminação. Cabe ao proprietário do equipamento identificar os centros de recolha autorizados, solicitando informações às autoridades locais. A aplicação da Diretiva Europeia irá permitir melhorar o ambiente e a saúde humana.



Após utilização, as perdas ou resíduos do produto devem ser processados numa instalação de tratamento adequada ou, se possível, o produto deverá ser reciclado. Não é permitido despejar o produto em cursos de água, fossas ou sistemas de drenagem. O fluido diluído não deve ser despejado na rede de esgotos, excepto se tal for permitido pela legislação local.

2. INSTALAÇÃO

2.1 Elevação, transporte e descarga

- O equipamento não dispõe de elementos específicos para elevação.



Nunca subestimar o peso do equipamento, (ver características técnicas).

Nunca deslocar, ou posicionar, a carga suspensa sobre pessoas ou bens.

Não deixar cair o equipamento, nem exercer pressão desnecessária sobre ele.

2.2 Posicionamento do equipamento



Observar as seguintes regras:

- Fácil acesso aos comandos e ligações do equipamento.
 - Não colocar o equipamento em espaços reduzidos.
 - Nunca colocar o equipamento num plano com inclinação superior a 10° em relação ao plano horizontal.
 - Ligar o equipamento num lugar seco, limpo e com ventilação apropriada.
 - Proteger o equipamento da chuva e do sol.
- » Consultar a secção “Precauções na utilização das botijas de gás”.

2.3 Ligações



Antes da qualquer operação de manutenção, desligar o equipamento da corrente eléctrica!

2.4 Instalação

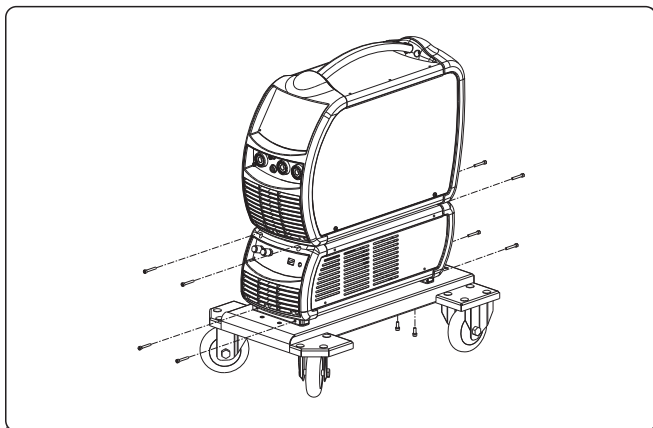

- ▶ Apoiar o WU sobre o GT e fixá-lo com os 4 parafusos.
- ▶ Colocar o gerador sobre o grupo de refrigeração e fixá-lo com os parafusos previstos para o efeito.

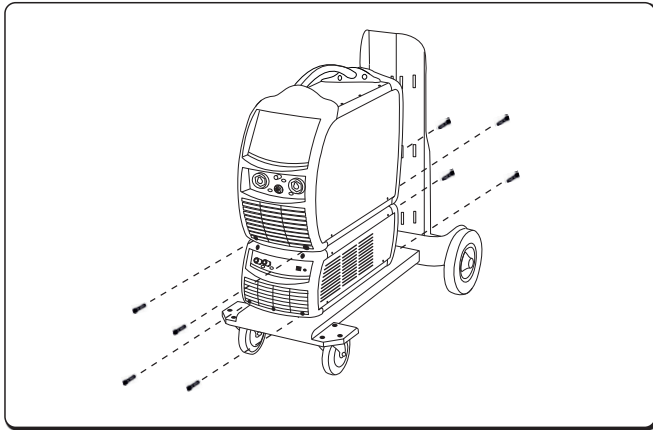

- ▶ Apoiar o WU sobre o GT e fixá-lo com os 4 parafusos.
- ▶ Colocar o gerador sobre o grupo de refrigeração e fixá-lo com os parafusos previstos para o efeito.

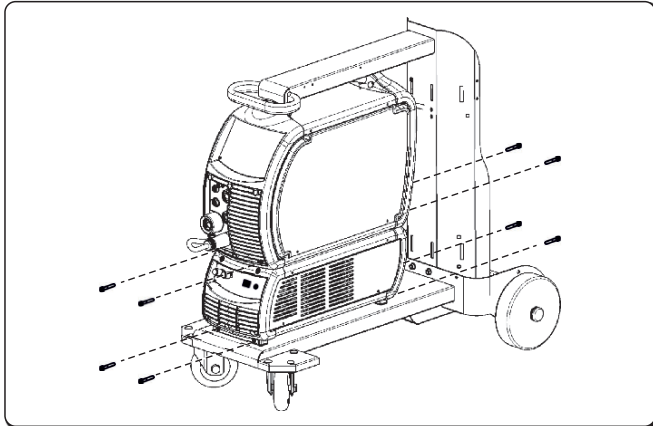

- ▶ Apoiar o WU sobre o GT e fixá-lo com os 4 parafusos.
- ▶ Colocar o gerador sobre o grupo de refrigeração e fixá-lo com os parafusos previstos para o efeito.

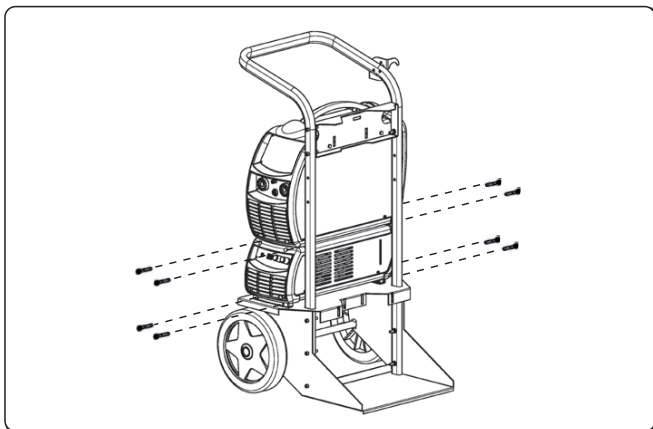

- ▶ Apoiar o WU sobre o GT e fixá-lo com os 4 parafusos.
- ▶ Colocar o gerador sobre o grupo de refrigeração e fixá-lo com os parafusos previstos para o efeito.

PT



Antes de pôr o grupo em funcionamento, executar as seguintes operações:

- ▶ Retirar a tampa do reservatório.
- ▶ Retirar a tampa hermética do bocal, fazendo alavanca com uma ferramenta apoiada no bordo da tampa.
- ▶ Se necessário, acrescentar líquido ao reservatório.
- ▶ Conservar a tampa hermética, para futuras utilizações no transporte do grupo.



Para não danificar a unidade de refrigeração, montar sempre o tubo by-pass quando a tocha não está ligada aos terminais de entrada/saída do líquido de refrigeração.



O reservatório deve ser cheio com líquido de refrigeração cód. 18.91.008.

2.4.1 Ligação do painel traseiro

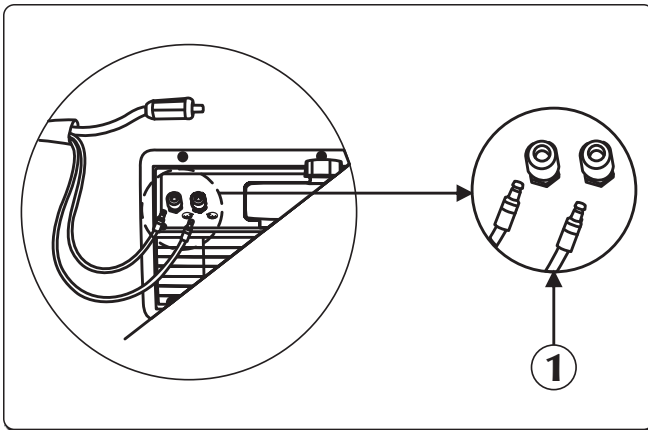

① Entrada/Saída de líquido de refrigeração

- ▶ Ligar o tubo de água (azul escuro) ao conector rápido de saída (azul escuro) da unidade de refrigeração.
- ▶ Ligar o tubo de água (vermelho) ao conector rápido de entrada (vermelho) da unidade de refrigeração.

2.4.2 Ligação do painel frontal

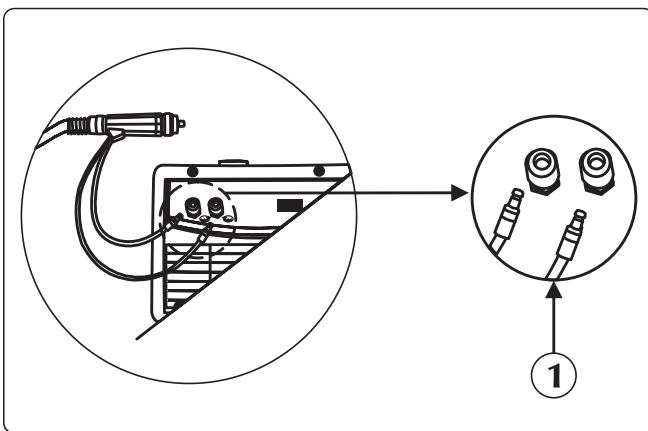

① Entrada/Saída de líquido de refrigeração

- ▶ Ligar o tubo de água da tocha (azul escuro) ao conector rápido de saída da unidade de refrigeração.
- ▶ Ligar o tubo de água da tocha (vermelho) ao conector rápido de entrada da unidade (vermelho) de refrigeração.

3. APRESENTAÇÃO DO SISTEMA

3.1 Painel traseiro

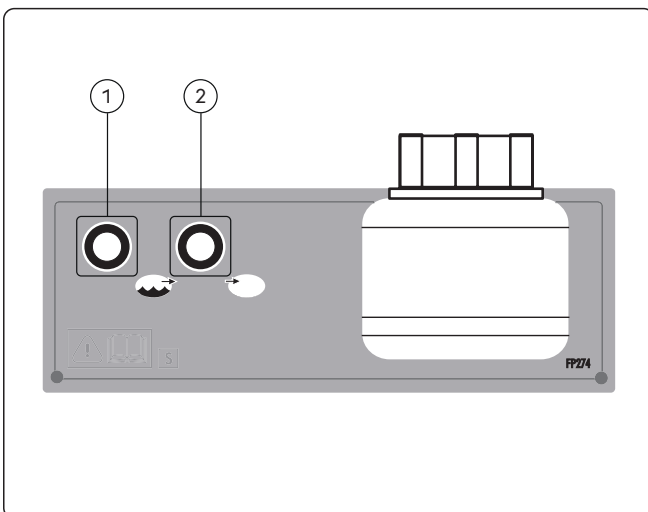

① Ligação de saída do líquido de refrigeração

Permite introduzir o líquido a baixa temperatura no circuito de refrigeração da tocha.

② Ligação de entrada do líquido de refrigeração

Permite introduzir líquido, sujeito ao aquecimento da tocha, no circuito de refrigeração interno da WU.

3.2 Painel de comandos frontal

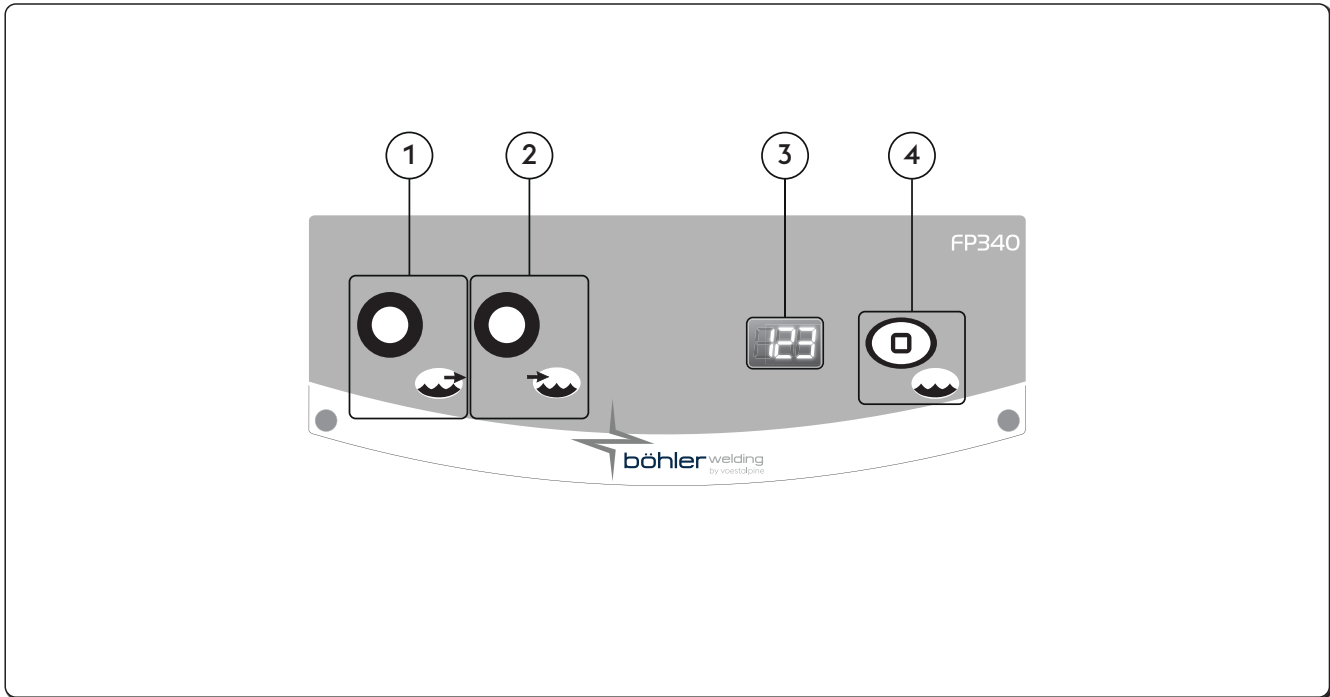

- 1** **Ligação de saída do líquido de refrigeração**
 Permite introduzir o líquido a baixa temperatura no circuito de refrigeração da tocha.
- 2** **Ligação de entrada do líquido de refrigeração**
 Permite introduzir líquido, sujeito ao aquecimento da tocha, no circuito de refrigeração interno da WU.
- 3** **Visor de 7 segmentos**
 Permite visualizar os parâmetros gerais da WU durante a inicialização, o correcto funcionamento e a temperatura interna do fluido de refrigeração.
 -- Unidade de refrigeração desactivada.
- 4** **Teste da unidade de refrigeração**

4. MANUTENÇÃO

- A instalação deve ser submetida a operações de manutenção de rotina, de acordo com as indicações do fabricante. Quando o equipamento está em funcionamento, todas as portas e tampas de acesso e de serviço deverão estar fechadas e trancadas. Os sistemas não devem ser submetidos a qualquer tipo de modificação. Evitar a acumulação de poeiras condutoras de electricidade perto das aletas de ventilação e sobre as mesmas.
- As operações de manutenção deverão ser efectuadas exclusivamente por pessoal especializado. A reparação ou substituição de componentes do sistema que seja executada por pessoal não-autorizado implica a imediata anulação da garantia do produto. A eventual reparação ou substituição de componentes do sistema tem de ser executada exclusivamente por pessoal técnico qualificado.



Antes da qualquer operação de manutenção, desligar o equipamento da corrente eléctrica!

4.1 Efectuar periodicamente as seguintes operações

- Verificar periodicamente o nível do líquido de refrigeração no reservatório. O esvaziamento total do reservatório e/ou a presença de ar na bomba, podem provocar anomalias de funcionamento.

- Limpar o interior do gerador com ar comprimido a baixa pressão e com escovas de cerdas suaves.
- Verificar as ligações eléctricas e todos os cabos de ligação.
- Verificar o estado as condições da electrobomba.
- Verificar o estado das ligações dos tubos.

Acada seis meses, mudar o líquido de refrigeração e lavar os tubos e o reservatório com água. Caso ferva, mudar o líquido, pois poderia perder as propriedades metálicas de protecção.



O enchimento do reservatório com líquido refrigerante deve ser executado com gerador e WU montados e colocados num plano horizontal.



O reservatório deve ser cheio com líquido de refrigeração cód. 18.91.008.
O equipamento não deve ser utilizado sem líquido de refrigeração.



Não utilizar líquidos de refrigeração condutivos.



Limpar o interior do gerador com ar comprimido a baixa pressão e com escovas de cerdas suaves. Verificar as ligações eléctricas e todos os cabos de ligação.

4.2 Ansvär



Caso a referida manutenção não seja executada, todas as garantias serão anuladas, isentando o fabricante de toda e qualquer responsabilidade. O incumprimento destas instruções isentará o fabricante de toda e qualquer responsabilidade. Se tiver quaisquer dúvidas e/ou problemas, não hesite em contactar o centro de assistência técnica mais perto de si.

5. CÓDIGOS DE ALARME



ALARME















A intervenção de um alarme ou a superação de um limite de alerta crítico provoca um sinal visual no painel de comando e o bloqueio imediato das operações de soldadura.



ATENÇÃO

A ultrapassagem de um limite de alerta provoca uma assinalação visual no painel de comando, mas permite continuar as operações de soldadura.

Incluimos, a seguir, uma lista com todos os alarmes e limites de alerta inerentes ao sistema.

 E43	Falta de líquido refrigerante		 E71	Sobretensão do líquido refrigerante	
 E76	Nível de fluxo do líquido refrigerante ultrapassado		 E77	Nível de temperatura do líquido refrigerante	
 E81	Sobrecorrente (bomba WU)		 E82	Erro de comunicação (WU)	
 E83	Bomba bloqueada				

6. RESOLUÇÃO DE PROBLEMAS

Ausência de fluxo no circuito

Causa

- » Ausência de líquido no reservatório.
- » Ar no circuito de refrigeração.

Solução

- » Efectuar o enchimento.
- » Aplicar o by-pass na ligação de saída (cor azul) e purgar o circuito hidráulico, deixando sair o líquido de refrigeração durante alguns segundos.

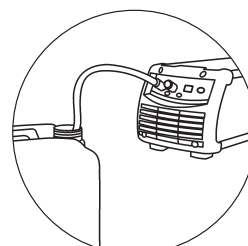

» Circuito de refrigeração bloqueado ou avariado.	<ul style="list-style-type: none"> » Verificar o estado das ligações (no interior da unidade) do circuito hidráulico. » Verificar o estado do circuito hidráulico da tocha. » Verificar o estado do circuito de refrigeração no feixe de cabos. » Contactar o centro de assistência mais próximo para a reparação do sistema.
» Presença do sinal de alarme da unidade de refrigeração.	<ul style="list-style-type: none"> » Repor o alarme no estado original. » Ligar uma tocha ou o by-pass nos modos de funcionamento que requeiram a activação da unidade de refrigeração. » Verificar o estado das ligações (no interior da unidade) do circuito hidráulico. » Verificar o estado do circuito hidráulico da tocha. » Contactar o centro de assistência mais próximo para a reparação do sistema.
» Anomalia na bomba.	<ul style="list-style-type: none"> » Substituir o componente danificado. » Contactar o centro de assistência mais próximo para a reparação do sistema.







Capacidade de refrigeração insuficiente

Causa	Solução
» Anomalia na ventoinha.	<ul style="list-style-type: none"> » Substituir o componente danificado. » Contactar o centro de assistência mais próximo para a reparação do sistema.
» Anomalia na bomba.	<ul style="list-style-type: none"> » Substituir o componente danificado. » Contactar o centro de assistência mais próximo para a reparação do sistema.





7. CARACTERÍSTICAS TÉCNICAS

Características elétricas			U.M.
Tensão de alimentação U1	360		Vdc
Corrente máxima de entrada I1max	0.4		A
Potência de refrigeração (25°C)	1000		W
Características físicas			U.M.
Grau de protecção IP	IP23S		
Dimensões (lxwxh)	660x240x220		mm
Peso	12.0		Kg
Tipo de permutador	H ₂ O - Ar		
Caudal nominal (QV)	2.3		l/min
Caudal máximo bomba (Qvmax)	4.6		l/min
Altura de elevação bomba (Hmax)	35		m
Tipo de bomba	Rotativa		
Nº rotações máximo	3300		RPM
Capacidade do reservatório	3.0		l
Normas de construção	EN IEC 60974-2:2019 EN 60974-10/A1:2015		

8. PLACA DE DADOS

 VOESTALPINE BÖHLER WELDING ARC TECHNOLOGY S.R.L. Via Palladio,19 - ONARA (PADOVA) - ITALY		
WU 2000	N°	
EN IEC	60974-2:2019 60974-10/A1:2015 Class A	
Energy input		
	U₁ 350V	I_{1max} 0.35A
	IP 23 S	
Liquid cooling system		
	P_{11/min} 1.0kW	P_{max} 0.35MPa (3.5bar)
		  
	MADE IN ITALY	

9. SIGNIFICADO DA PLACA DE DADOS

1		2	
3		4	
5			
6			
6	7	8	
	9		
10			
10	11	12	
		  	
	MADE IN ITALY		

- 1 Marca de fabrico
- 2 Nome e morada do fabricante
- 3 Modelo de equipamento
- 4 N.º de série
- XXXXXXX** Ano de fabrico
- 5 Referência às normas de fabrico
- 6 Símbolo para a alimentação
- 7 Tensão nominal de alimentação
- 8 Corrente nominal máxima de alimentação
- 9 Grau de proteção
- 10 Símbolo do sistema de refrigeração
- 11 Potência de refrigeração
- 12 Pressão máxima

CE Declaração de conformidade UE
 EAC Declaração de conformidade EAC
 UKCA Declaração de conformidade UKCA

EU-CONFORMITEITSVERKLARING

De bouwer
voestalpine Böhler Welding Arc Technology S.r.l.
ia Palladio, 19 - 35019 Onara di Tombolo (PD) - ITALY
Tel. +39 049 9413/111 - Fax +39 049 9413/311 - www.voestalpine.com/welding

verklaart onder eigen verantwoordelijkheid dat het volgende product:

WU 2000 **71.03.076**

conform is met de normen EU:

2014/35/EU **LOW VOLTAGE DIRECTIVE**

2014/30/EU **EMC DIRECTIVE**

2011/65/EU **RoHS DIRECTIVE**

en dat de volgende geharmoniseerde normen zijn toegepast:

EN IEC 60974-2:2019 **LIQUID COOLING SYSTEMS**

EN 60974-10/A1:2015 **ELECTROMAGNETIC COMPATIBILITY REQUIREMENTS**

De documentatie waaruit blijkt dat aan de richtlijnen wordt voldaan, wordt ter inzage gehouden bij de bovengenoemde fabrikant.

Iedere ingreep of modificatie die niet vooraf door voestalpine Böhler Welding Arc Technology S.r.l. is goedgekeurd maakt dit certificaat ongeldig.

Onara di Tombolo, 01/05/2025

voestalpine Böhler Welding Arc Technology S.r.l.



Mirco Frasson **Ivo Bonello**

Managing Directors

INHOUDSOPGAVE

1. WAARSCHUWING	79
1.1 Gebruiksomgeving.....	79
1.2 Bescherming voor de lasser en anderen.....	79
1.3 Beveiliging tegen elektrische schokken.....	80
1.4 Elektromagnetische velden en storingen.....	80
1.5 IP Beveiligingsgraad.....	80
1.6 Koelvloeistof.....	80
2. HET INSTALLEREN	81
2.1 Procedure voor het laden, vervoeren en lossen.....	81
2.2 Plaatsen van de installatie.....	81
2.3 Aansluiting.....	81
2.4 Installeren.....	81
3. PRESENTATIE VAN DE INSTALLATIE	83
3.1 Achter paneel.....	83
3.2 Bedieningspaneel vooraan.....	84
4. ONDERHOUD	84
4.1 Controleer de stroombron regelmatig als volgt.....	84
4.2 Odpovědnost.....	85
5. ALARM CODES	85
6. MEEST VOORKOMENDE VRAGEN EN OPLOSSINGEN	85
7. TECHNISCHE KENMERKEN	86
8. GEGEVENSPLAAT	87
9. BETEKENIS GEGEVENSPLAATJE	87
10. SCHEMA	149
11. VERBINDINGEN	150
12. LIJST VAN RESERVE ONDERDELEN	151

NL

SYMBOLLEN



Waarschuwing



Verboden



Verplichtingen



Algemene indicaties

1. WAARSCHUWING



Voor het gebruik van de machine dient u zich ervan te overtuigen dat u de handleiding goed heeft gelezen en begrepen.

Breng geen veranderingen aan en voer geen onderhoudswerkzaamheden uit die niet in deze handleiding vermeld staan. De fabrikant kan niet verantwoordelijk worden gehouden voor lichamelijke schade of schade aan eigendommen die zijn veroorzaakt door verkeerd gebruik van de machine of het onjuist interpreteren van de handleiding.

Bewaard de gebruiksaanwijzing altijd op de plaats waar het apparaat wordt gebruikt. Naast de gebruiksaanwijzing dienen ook de algemene regels en plaatselijke voorschriften ter voorkoming van ongevallen en ter bescherming van het milieu in acht te worden genomen.

voestalpine Böhler Welding Arc Technology S.r.l. behoudt zich het recht voor deze handleiding te allen tijde te kunnen wijzigen zonder voorafgaande aankondiging.

Het is verboden zonder voorafgaande schriftelijke toestemming van voestalpine Böhler Welding Arc Technology S.r.l. deze handleiding te vertalen of geheel of gedeeltelijk te kopiëren (hierbij inbegrepen zijn fotokopieën, film of microfilm). Deze richtlijnen zijn van vitaal belang en dienen strikt te worden opgevolgd om aanspraak te kunnen maken op garantie.

De fabrikant accepteert geen enkele aansprakelijkheid als de gebruiker zich niet heeft gehouden aan deze richtlijnen.



Ledereen die met de inbedrijfstelling, het gebruik, het onderhoud en de reparatie van het apparaat is belast moet:

- in het bezit zijn van een passende kwalificatie
- deze gebruiksaanwijzing volledig doorlezen en strikt naleven

In geval van twijfel of problemen bij het gebruik, zelfs als het niet staat vermeldt, raadpleeg uw leverancier.

1.1 Gebruiksomgeving



Iedere machine mag alleen worden gebruikt voor de werkzaamheden waarvoor hij is ontworpen, op de manier zoals is voorschreven op de gegevensplaat en/of deze handleiding, in overeenstemming met de nationale en internationale veiligheidsvoorschriften. Oneigenlijk gebruik zal worden gezien als absoluut ongepast en gevaarlijk en in een dergelijk geval zal de fabrikant iedere verantwoordelijkheid afwijzen.



Deze apparatuur dient uitsluitend voor professionele doeleinde te worden gebruikt in een industriële omgeving. De fabrikant kan niet aansprakelijk worden gesteld voor schade veroorzaakt door gebruik van de apparatuur in een huishoudelijke omgeving.



De omgevingstemperatuur voor gebruik van de machine moet liggen tussen -10° C en +40° C (Tussen +14°F en +104°F).

Voor transport en opslag moet de temperatuur liggen tussen -25°C en +55°C (tussen -13°F en +131°F).

De machine moet worden gebruikt in een stofvrije omgeving zonder zuren, gas of andere corrosieve stoffen.

De vochtigheidsgraad van de werkomgeving van de machine mag niet hoger zijn dan 50% bij 40°C (104°F).

De vochtigheidsgraad van de werkomgeving van de machine mag niet hoger zijn dan 90% bij 20°C (68°F).

De machine kan worden gebruikt tot op een hoogte van 2000 meter boven de zeespiegel (6500 voet).

1.2 Bescherming voor de lasser en anderen



Controleer vooraf of de toorts koud is voor u begint met lassen of met onderhoud begint.



Overtuig u ervan dat de koelunit is uitgeschakeld voordat u de leidingen van de koelvloeistof losmaakt. De hete vloeistof uit de leidingen kan ernstige brandwonden veroorzaken.



Houd een verbanddoos binnen handbereik.

Onderschat brandwonden of andere verwondingen nooit.



Overtuigt u er voor dat u vertrekt van dat de werkplek goed is opgeruimd, zo voorkomt u ongevallen.

1.3 Beveiliging tegen elektrische schokken



Elektrische schokken kunnen dodelijk zijn.

- Vermijd het aanraken van spanningvoerende delen binnen of buiten de lasapparatuur terwijl de apparatuur zelf onder spanning staat (toortsen, klemmen, massakabels, elektroden, draden, haspels en spoelen zijn elektrisch verbonden met het lascircuit).
- Zorg voor elektrische isolatie van het systeem en de bediener door droge vloeren en ondergronden te gebruiken die voldoende geïsoleerd zijn van het massa- en aardingspotentiala.

1.4 Elektromagnetische velden en storingen

1.4.1 EMC classificatie in overeenstemming met: EN 60974-10/A1:2015.



Klasse B apparatuur voldoet aan de elektromagnetische eisen van aansluiting zowel wat betreft de industriële omgeving als de woonomgeving, inclusief de woonomgeving waar de stroomvoorziening wordt betrokken van het netwerk en dus met een lage spanning.



Klasse A apparatuur is niet bedoeld om te gebruiken in de woonomgeving waar de stroom geleverd wordt via het normale netwerk met lage spanning. In een dergelijke omgeving kunnen zich potentiële moeilijkheden voordoen bij het veilig stellen van de elektromagnetische aansluiting van klasse A apparatuur veroorzaakt door geleiding of storing door straling.

Zie voor meer informatie: GEGEVENSPLAAT of TECHNISCHE KENMERKEN.

1.4.2 Installatie, gebruik en evaluatie van de werkplek

Deze apparatuur is gebouwd volgens de aanwijzingen in de geharmoniseerde norm EN 60974-10/A1:2015 en wordt gerekend tot de Klasse A. Deze apparatuur dient uitsluitend voor professionele doeleinde te worden gebruikt in een industriële omgeving. De fabrikant kan niet aansprakelijk worden gesteld voor schade veroorzaakt door gebruik van de apparatuur in een huishoudelijke omgeving.



De gebruiker moet een vakkundig iemand zijn die zich verantwoordelijk voelt voor de apparatuur en er gebruik van maakt volgens de richtlijnen van de fabrikant. Wanneer zich elektromagnetische storingen voordoen moet de lasser de problemen oplossen zonodig met de technische assistentie van de fabrikant.



In ieder geval dient de elektromagnetische storing zodanig gereduceerd te worden dat het geen hinder meer vormt.



Voor de installatie dient de gebruiker de risico's te evalueren die elektromagnetische storingen zouden kunnen opleveren voor de directe omgeving, hierbij in het bijzonder lettend op de gezondheidsrisico's voor personen op en in de omgeving van de werkplek, bij voorbeeld mensen die een pacemaker of een gehoorapparaat hebben.

1.4.3 Afscherming

Door het selectief afschermen van andere kabels en apparatuur in de directe omgeving kunnen de storingsproblemen afnemen.

Bij speciale toepassingen kan het worden overwogen de gehele lasplaats af te schermen.

1.5 IP Beveiligingsgraad



IP23S

- De kast voorkomt dat gevaarlijke onderdelen met de vingers of voorwerpen met een diameter tot 12.5mm kunnen worden aangeraakt.
- De kast beschermt tegen inregenen tot een hoek van 60° in verticale stand.
- De kast beschermt tegen de gevolgen van binnen druppelend water als de machine niet aanstaat.

1.6 Koelvloeistof

1.6.1 Persoonlijke bescherming



Inslikken van het product is schadelijk.
Het kan irritatie veroorzaken aan de ogen, slijmvlies en de huid.



Gebruik rubber handschoenen om aanraking te voorkomen.



Maak gebruik van een veiligheidsbril tegen spetters.



Draag normale werkkleding zodat contact met de huid wordt voorkomen.

1.6.2 Verwijdering



Verwijder elektrische apparatuur niet bij het normale afval!

In overeenstemming met de Europese Richtlijn 2012/19/EU betreffende afgedankte elektrische en elektronische apparatuur en de uitvoering daarvan in overeenstemming met de nationale wetgevingen, moet elektrische apparatuur die het einde van haar levenscyclus heeft bereikt, gescheiden worden ingezameld en naar een centrum voor nuttige toepassing en verwijdering worden gebracht. De eigenaar van de apparatuur dient bij de plaatselijke autoriteiten te informeren naar de erkende inzamelpunten. Door toepassing van de Europese richtlijn kunnen het milieu en de menselijke gezondheid worden verbeterd.



Na gebruik moeten gelekte vloeistof en andere afvalresten van het product op de juiste manier opgeruimd of indien mogelijk gerecycled worden. Het is verboden de resten weg te spoelen in open water, sloten of afwateringssystemen. De verdunde vloeistof mag niet worden geloosd in het riool tenzij met toestemming van de plaatselijke autoriteiten.

2. HET INSTALLEREN

2.1 Procedure voor het laden, vervoeren en lossen

- De machine is niet uitgerust met speciale hulpstukken voor bij het tillen.



Onderschat het gewicht van de apparatuur niet, zie de technische specificatie.
Beweeg of hang het apparaat nooit boven personen of voorwerpen.
Laat het apparaat niet vallen of botsen.

2.2 Plaatsen van de installatie



Houdt u aan onderstaande regels:

- Zorg ervoor dat de installatie en de aansluitingen goed toegankelijk zijn.
- Plaats het apparaat niet in een te kleine ruimte.
- Plaats het apparaat niet op een schuin aflopende ondergrond van meer dan 10° waterpas.
- Plaats het apparaat in een droge, schone en goed geventileerde ruimte.
- Bescherm het apparaat tegen hevige regen en tegen de zon.
- » Raadpleeg het gedeelte "Voorzorgmaatregelen voor het gebruik van gasflessen".

2.3 Aansluiting



Schakel de stroomtoevoer altijd uit voor u onderhoud pleegt.

2.4 Installeren

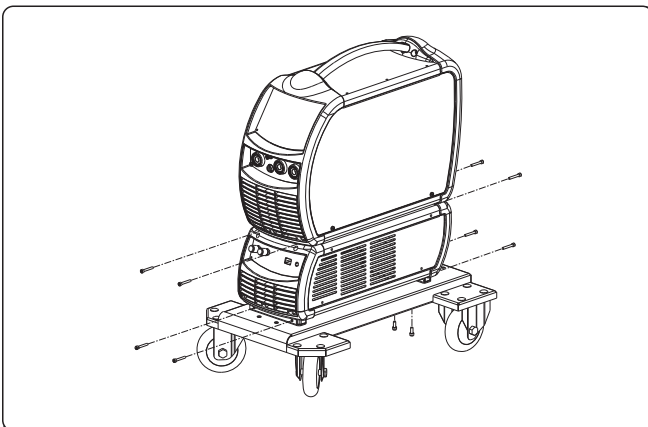

- ▶ Zet de WU op de GT en zet hem vast met vier schroeven.
- ▶ Plaats de generator bovenop de koelunit en zet hem vast met de schroeven.

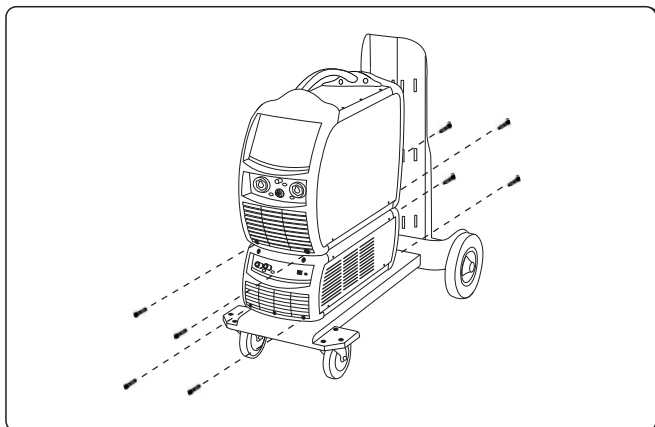

- ▶ Zet de WU op de GT en zet hem vast met vier schroeven.
- ▶ Plaats de generator bovenop de koelunit en zet hem vast met de schroeven.

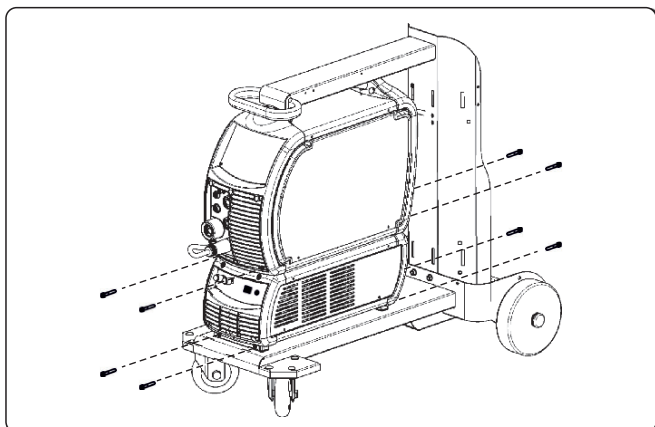

- ▶ Zet de WU op de GT en zet hem vast met vier schroeven.
- ▶ Plaats de generator bovenop de koelunit en zet hem vast met de schroeven.

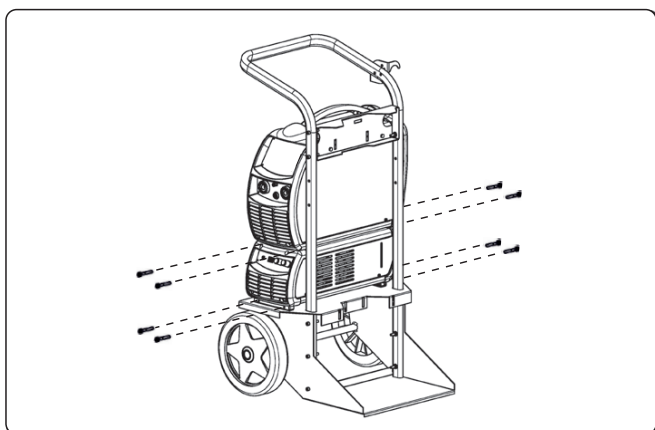

- ▶ Zet de WU op de GT en zet hem vast met vier schroeven.
- ▶ Plaats de generator bovenop de koelunit en zet hem vast met de schroeven.



Voer de volgende handelingen uit voor u de unit start:

- ▶ Verwijder de dop van de bijvul tuit.
- ▶ Verwijder de afsluit dop van de bijvul tuit, wip hem omhoog met een stuk gereedschap onder de rand van de dop.
- ▶ Vul zondig de tank met koelvloeistof.
- ▶ Bewaar de afsluitdop voor wanneer u de unit moet vervoeren.



Om schade aan de koelunit te voorkomen dient u de bypass leiding altijd aan te sluiten als de toorts nog niet is verbonden met de aan en afvoerleidingen van de koelvloeistof.



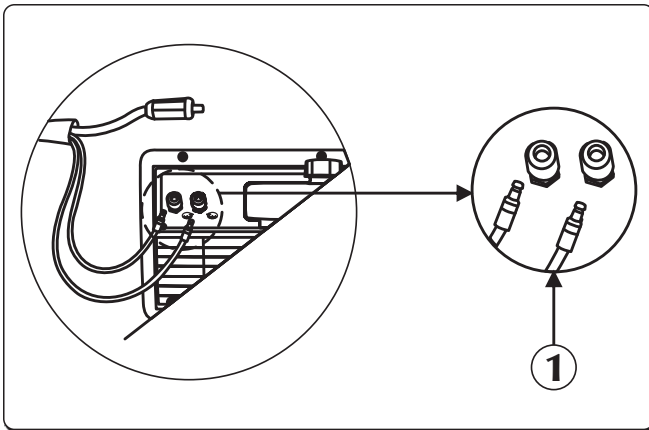

Het vullen of bijvullen van de tank moet gebeuren met koelvloeistof, code 18.91.008.

2.4.1 Aansluiting achterpaneel





① Koelvloeistof inlet /outlet

- ▶ Verbindt de slang voor de koelvloeistof (kleur blauw) van het tussenpakket met de snelkoppeling (kleur blauw - symbool ) van de koelunit.
- ▶ Verbindt de slang voor de koelvloeistof (kleur rood) van het tussenpakket met de snelkoppeling (kleur rood - symbool ) van de koelunit.

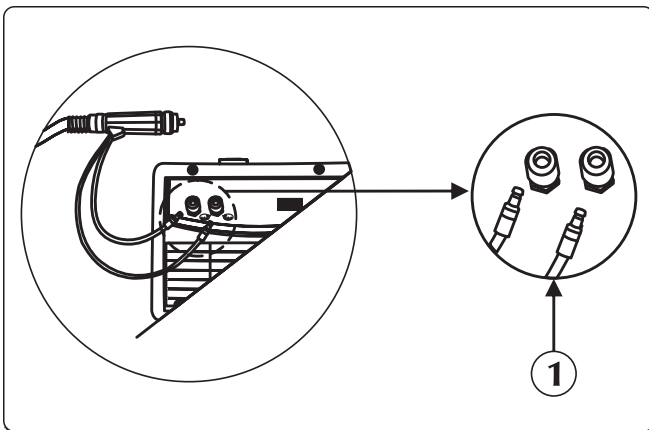
2.4.2 Aansluiting voorpaneel



① Koelvloeistof inlet /outlet

- ▶ Verbindt de slang voor koelvloeistof (kleur blauw) van de toorts met de snelkoppeling (kleur blauw - symbool ) van de koelunit.
- ▶ Verbindt de slang voor koelvloeistof (kleur rood) van de toorts met de snelkoppeling (kleur rood - symbool ) van de koelunit.

NL

3. PRESENTATIE VAN DE INSTALLATIE

3.1 Achter paneel

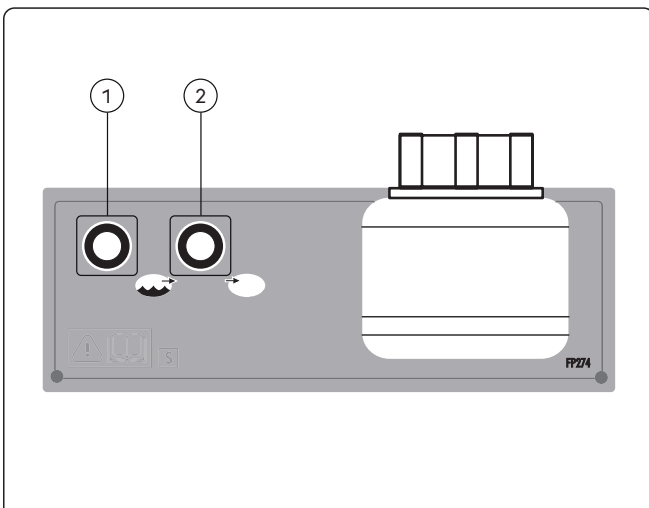

- ① **Verbindingsstuk/uitlaatkoppeling koelvloeistof**
Om vloeistof met een lage temperatuur in het koelcircuit van de toorts te doen.
- ② **Verbindingsstuk/inlaatkoppeling koelvloeistof**
Om vloeistof die door de toorts sterk is verwarmd terug te doen in het koelcircuit van de WU.

3.2 Bedieningspaneel vooraan

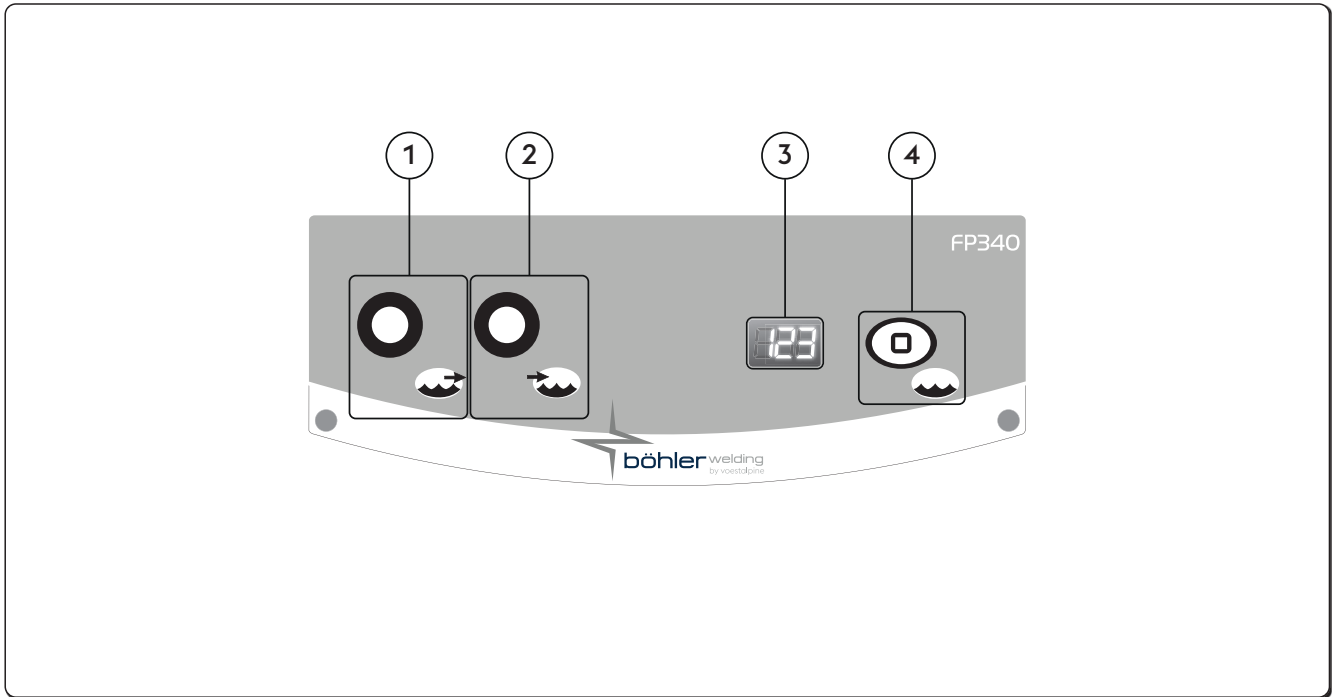

- 1 Verbindingsstuk/uitlaatkoppeling koelvloeistof**
 Om vloeistof met een lage temperatuur in het koelcircuit van de toorts te doen.
- 2 Verbindingsstuk/inlaatkoppeling koelvloeistof**
 Om vloeistof die door de toorts sterk is verwarmd terug te doen in het koelcircuit van de WU.
- 3 7-segmenten display**
 Toont de algemene parameters van de WU tijdens het inschakelen, de juiste werking en de interne temperatuur van de koelvloeistof.
 -- Koelunit defect.
- 4 Koel unit test**

4. ONDERHOUD

- De normale onderhoud werkzaamheden moeten worden uitgevoerd volgens de richtlijnen die de fabrikant heeft verstrekt. Als de machine is ingeschakeld moeten alle ingangspunten en panelen zijn gesloten. De installatie mag op geen enkele manier worden gewijzigd. Voorkom ophoping van metaalstof bij of op het koelrooster.
- Iedere onderhoud beurt dient te worden gedaan door gekwalificeerd personeel. Bij reparatie of vervanging van een onderdeel in de machine door onbevoegd personeel vervalt de garantie. De reparatie of vervanging van een onderdeel in de machine dient te worden gedaan door gekwalificeerd personeel.
- Schakel de stroomtoevoer altijd uit voor u onderhoud pleegt.

4.1 Controleer de stroombron regelmatig als volgt

- Controleer regelmatig het niveau van de koelvloeistof. Als de tank helemaal leeg is of als er lucht in de leidingen zit kan de pomp haperen.
- Reinig de machine aan de binnenkant door hem uit te blazen en af te borstelen met een zachte borstel.
 - Controleer de elektriciteitsnoeren en alle verbindingkabels.
 - Controleer de staat van de elektrische pomp.
 - Controleer de staat van de slangklemmen.

Ververs iedere zes maanden de koelvloeistof en reinig de slangen en de tank met water. Vervang de vloeistof als het heeft gekookt omdat daardoor de beschermende eigenschappen verloren zijn gegaan.



Het vullen of bijvullen van de tank met koelvloeistof moet worden gedaan met de generator en de WU samengevoegd en geplaatst op een horizontale ondergrond.



Het vullen of bijvullen van de tank moet gebeuren met koelvloeistof, code 18.91.008. De apparatuur mag niet worden gebruikt zonder koelvloeistof.



Gebruik geen geleidende koelvloeistoffen.



Reinig de machine aan de binnenkant door hem uit te blazen en af te borstelen met een zachte borstel. Controleer de elektrische aansluitingen en de kabels.

4.2 Odpovědnost



Als geen regelmatig onderhoud wordt uitgevoerd, vervalt de garantie en wordt de fabrikant van alle aansprakelijkheid ontheven. De fabrikant wijst ieder verantwoordelijkheid af wanneer de gebruiker zich niet houdt aan de volgende richtlijnen. In geval van twijfel of problemen aarzel niet contact op te nemen met uw leverancier.

5. ALARM CODES



ALARM















De tussenkomst van een alarm of de overschrijding van een kritieke waarschuwingsgrens veroorzaakt een visueel signaal op het bedieningspaneel en de onmiddellijke stopzetting van de laswerkzaamheden.



Let op!

De overschrijding van een waarschuwingsgrens veroorzaakt een visueel signaal op het bedieningspaneel maar de laswerkzaamheden kunnen worden voortgezet.

Hieronder volgt een lijst van alle alarmen en waarschuwingsgrenzen met betrekking tot het systeem.

 E43	Geen koelvloeistof		 E71	Overtemperatuur koelvloeistof	
 E76	Stromingsniveau koelvloeistof overschreden		 E77	Temperatuurniveau koelvloeistof	
 E81	Overstroom (pomp WU)		 E82	Communicatiefout (WU)	
 E83	Pomp geblokkeerd				

NL

6. MEEST VOORKOMENDE VRAGEN EN OPLOSSINGEN

Geen vloeistof in het circuit

Vraag

- » Geen vloeistof in de tank.
- » Lucht in het koelcircuit.

Oplossing

- » Vloeistof bijvullen.
- » Verbind de by-pass met de outlet aansluiting (kleur blauw) en tapt het hydraulische circuit af waardoor de koelvloeistof binnen enkele seconden te voorschijn komt.

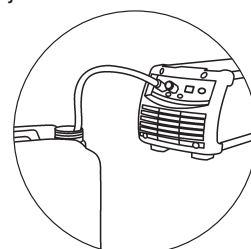

- | | |
|---|--|
| <ul style="list-style-type: none"> » Koelcircuit verstopt of onderbroken. | <ul style="list-style-type: none"> » Controleer de status van de verbindingen van het hydraulische circuit (binnen in de unit). » Controleer de status van het hydraulische circuit van de toorts. » Controleer de toestand van het hydraulisch circuit van de kabelbundel. » Neem contact op met uw leverancier om de machine te laten repareren. |
| <ul style="list-style-type: none"> » De aanwezigheid van het koelunit alarm. | <ul style="list-style-type: none"> » Reset het alarm. » Verbind een toorts of de by-pass bij een ingeschakelde stand waarbij de koelunit aan moet staan. » Controleer de status van de verbindingen van het hydraulische circuit (binnen in de unit). » Controleer de status van het hydraulische circuit van de toorts. » Neem contact op met uw leverancier om de machine te laten repareren. |
| <ul style="list-style-type: none"> » Pomp defect. | <ul style="list-style-type: none"> » Vervang het defecte onderdeel. » Neem contact op met uw leverancier om de machine te laten repareren. |

Onvoldoende koelvermogen

Vraag

- » Ventilator defect.
-
- » Pomp defect.







Oplossing

- » Vervang het defecte onderdeel.
 - » Neem contact op met uw leverancier om de machine te laten repareren.
-
- » Vervang het defecte onderdeel.
 - » Neem contact op met uw leverancier om de machine te laten repareren.





7. TECHNISCHE KENMERKEN

Elektrische kenmerken		U.M.
Netspanning U1	360	Vdc
Maximaal opgenomen stroom I1max	0.4	A
Koelvermogen (25°C)	1000	W
Fysieke eigenschappen		U.M.
IP Beveiligingsgraad	IP23S	
Afmetingen (lxdxh)	660x240x220	mm
Gewicht	12.0	Kg
Type warmtewisselaar	H ₂ O - Lucht	
Nominale doorstroom snelheid (QV)	2.3	l/min
Maximale doorstroom snelheid pomp (Qvmax)	4.6	l/min
Opvoerhoogte pomp (Hmax)	35	m
Type pomp	Roterende	
Maximaal toerental	3300	RPM
Tank inhoud	3.0	l
Constructienormen	EN IEC 60974-2:2019 EN 60974-10/A1:2015	

8. GEGEVENSPLAAT

 VOESTALPINE BÖHLER WELDING ARC TECHNOLOGY S.R.L. Via Palladio, 19 - ONARA (PADOVA) - ITALY		
WU 2000	N°	
EN IEC	60974-2:2019 60974-10/A1:2015 Class A	
Energy input		
	U₁ 350V	I_{1max} 0.35A
	IP 23 S	
Liquid cooling system		
	P_{11/min} 1.0kW	P_{max} 0.35MPa (3.5bar)
  		
MADE IN ITALY 		

9. BETEKENIS GEGEVENSPLAATJE

1		2	
3		4	
5			
6			
6	7		8
	9		
10			
10	11		12
  			
MADE IN ITALY 			

- 1 Fabrieksmerk
- 2 Naam en adres van de fabrikant
- 3 Model van de apparatuur
- 4 Serienummer
 XXXXXXXXXXXX Bouwjaar
- 5 Verwijzing naar de constructienormen
- 6 Symbool voor de voeding
- 7 Nominale voedingsspanning
- 8 Nominale maximale voedingsstroom
- 9 Beschermingsgraad
- 10 Koelsysteem symbool
- 11 Koelvermogen
- 12 Maximale druk

CE EU-Conformiteitsverklaring
 EAC EAC-Conformiteitsverklaring
 UKCA UKCA-Conformiteitsverklaring

EU-FÖRSÄKRAN OM ÖVERENSSTÄMMELSE

Byggaren
voestalpine Böhler Welding Arc Technology S.r.l.
Via Palladio, 19 - 35019 Onara di Tombolo (PD) - ITALY
Tel. +39 049 9413/111 - Fax +39 049 9413/311 - www.voestalpine.com/welding

förklarar under ensam ansvar att följande produkt:

WU 2000

71.03.076

överensstämmer med direktiven EU:

2014/35/EU LOW VOLTAGE DIRECTIVE

2014/30/EU EMC DIRECTIVE

2011/65/EU RoHS DIRECTIVE

och att följande harmoniserade standarder har tillämpats:

EN IEC 60974-2:2019

LIQUID COOLING SYSTEMS

EN 60974-10/A1:2015

ELECTROMAGNETIC COMPATIBILITY REQUIREMENTS

Dokumentationen som intygar överensstämmelse med direktiven kommer att finnas tillgänglig för inspektioner hos ovannämnda tillverkare.

Ingrepp eller modifieringar utan tillstånd av voestalpine Böhler Welding Arc Technology S.r.l. medför att denna försäkran inte längre är giltig.

Onara di Tombolo, 01/05/2025

voestalpine Böhler Welding Arc Technology S.r.l.



Mirco Frasson

Ivo Bonello

Managing Directors

INNEHÅLLSFÖRTECKNING

1. VARNING	91
1.1 Driftsmiljö	91
1.2 Personligt skydd och skydd för tredje man.....	91
1.3 Skydd mot elektriska urladdningar	91
1.4 Elektromagnetiska fält och störningar	92
1.5 IP-skyddsgrad	92
1.6 Kylvätska	92
2. INSTALLATION	93
2.1 Lyftning, transport och lossning	93
2.2 Aggregatets placering.....	93
2.3 Inkoppling.....	93
2.4 Igångsättning	93
3. BESKRIVNING AV AGGREGATET	95
3.1 Bakre kontrollpanel.....	95
3.2 Främre kontrollpanel	96
4. UNDERHÅLL	96
4.1 Periodiska kontroller av generatoren.....	96
4.2 Odpowiedzialność	97
5. LARMKODER	97
6. FELSÖKNING OCH TIPS	97
7. TEKNISKA DATA	98
8. MÄRKPLÅT	99
9. MÄRKPLÅTENS INNEBÖRD	99
10. KOPPLINGSSCHEMA	149
11. KONTAKTDON	150
12. RESERVDELSLISTA	151

SV

SYMBOLER



Varning



Förbud



Skyldigheter



Allmänna indikationer

1. VARNING



Läs den här instruktionsboken ordentligt och se till att du har förstått anvisningarna innan du börjar arbeta med maskinen.

Modifiera inte maskinen och utför inget underhåll som inte anges här. Tillverkaren påtar sig inget ansvar för person- eller saksador som uppkommer till följd av att denna instruktionsbok inte har lästs uppmärksam eller att instruktionerna i den inte har följts.

Förvara alltid bruksanvisningen på den plats där apparaten används. Följ utöver bruksanvisningen även de allmänna föreskrifterna och gällande lokala bestämmelser om förebyggande av olyckor och miljöskydd.

voestalpine Böhler Welding Arc Technology S.r.l. förbehåller sig rätten att modifiera produkten när som helst utan föregående meddelande.

voestalpine Böhler Welding Arc Technology S.r.l. förbehåller sig rättigheterna till och förbjuder översättning, reproduktion och anpassning, helt eller delvis, oavsett metod (inklusive fotostatkopior, film och mikrofilm) utan skriftligt tillstånd. Att dessa instruktioner följs är mycket viktigt och en förutsättning för att garantin ska gälla.

Tillverkaren påtar sig inget ansvar om operatören inte följer dessa anvisningar.



Alla personer som ansvarar för driftsättningen, användningen, underhållet och reparationen av apparaten ska

- ha rätt kvalifikation
- läsa hela bruksanvisningen och följa den noggrant

Rådfråga fackman om du är tveksam till hur aggregatet ska användas eller om du får problem.

1.1 Driftsmiljö



Aggregaten får endast användas för de ändamål som de har konstruerats för, på de sätt och de områden som anges på märkplåten och/eller i denna instruktionsbok, i enlighet med nationella och internationella säkerhetsnormer. Användning som avviker från vad tillverkaren uttryckligen har föreskrivit ska betraktas som helt olämplig och farlig. Tillverkaren påtar sig inget ansvar i sådana fall.



Denna apparat får endast användas för professionellt bruk i industrimiljö. Tillverkaren påtar sig inget ansvar för skador som orsakas av att aggregatet används i hemmiljö.



Aggregatet ska användas i omgivningar med temperatur på mellan -10 °C och +40 °C (mellan +14 °F och +104 °F). Aggregatet ska transporteras och förvaras i omgivningar med temperatur på mellan -25 °C och +55 °C (mellan -13 °F och +131 °F).

Miljön ska vara fri från damm, syror, gaser och andra frätande ämnen.

Den relativa luftfuktigheten ska vara högst 50 % vid 40 °C (104 °F).

Den relativa luftfuktigheten ska vara högst 90 % vid 20 °C (68 °F).

Aggregatet får användas på en höjd av högst 2000 m över havet (6500 fot).

1.2 Personligt skydd och skydd för tredje man



Kontrollera att brännaren har svalnat innan du utför arbeten eller underhåll på den.



Kontrollera att kylvätskan är avstängd innan du kopplar loss matarslangen och returslangen för kylvätskan. Den heta vätskan kan ge allvarliga brännskador.



Ha första hjälpen-utrustning tillgänglig.

Banaliser inte brännskador eller sår.



Säkra det område du ansvarar för innan du lämnar arbetsplatsen, för att motverka risken för person- och saksador.

1.3 Skydd mot elektriska urladdningar



Elektriska urladdningar kan vara livsfarliga.

- Undvik att vidröra delar som normalt är spänningsförande inuti eller utanför svetsstatet när det är strömförsörjt (brännare, gripklor, jordledare, elektroder, trådar, valsar och rullar är elektriskt anslutna till svetskretsen).
- Se till att aggregatet och operatören isoleras elektriskt genom att använda torra plan och underred som är tillfredsställande isolerade från nollpotentialen och jordpotentialen.

1.4 Elektromagnetiska fält och störningar

1.4.1 EMC-klassificeras i enlighet med: EN 60974-10/A1:2015.

- Klass B** Utrustning i klass B följer kraven på elektromagnetisk kompatibilitet för industri- och boendemiljöer, inklusive för bostadsområden där el levereras via det allmänna lågspänningsnätet.
- Klass A** Utrustning i klass A är inte avsedd för bruk i bostadsområden där elen levereras via det allmänna lågspänningsnätet. Det kan vara svårt att garantera elektromagnetisk kompatibilitet för utrustning i klass A på sådana platser, på grund av såväl ledningsbundna som strålade störningar.

För mer information, se kapitlet: MÄRKPLÅT eller TEKNISKA DATA.

1.4.2 Installation, drift och omgivningsbedömning

Denna apparat är konstruerad i överensstämmelse med anvisningarna i den harmoniserade standarden EN 60974-10/A1:2015 och tillhör Klass A. Denna apparat får endast användas för professionellt bruk i industrimiljö. Tillverkaren påtar sig inget ansvar för skador som orsakas av att aggregatet används i hemmiljö.



Användaren ska vara expert på området och är som sådan ansvarig för att apparaten installeras och används enligt tillverkarens anvisningar. Vid eventuella elektromagnetiska störningar ska användaren lösa problemet med hjälp av tillverkarens tekniska service.



De elektromagnetiska störningarna måste alltid minskas så mycket att de inte medför besvär.



Innan apparaten installeras ska användaren bedöma vilka eventuella elektromagnetiska problem som kan uppstå i det omgivande området och särskilt hälsotillståndet hos personalen i området, till exempel de som använder pacemakrar eller hörapparater.

1.4.3 Skärmning

Selektiv skärmning av andra kablar och apparater i omgivningarna kan minska störningsproblemen. För speciella applikationer kan man överväga att skärma hela svetsanläggningen.

1.5 IP-skyddsgrad

- IP** **IP23S**
- Höljet förhindrar att man kommer åt farliga delar med fingrarna och skyddar mot fasta främmande föremål med en diameter på 12,5 mm eller mer.
 - Höljet skyddar mot regn i 60° vinkel mot vertikalled.
 - Höljet är skyddat mot skador till följd av inträngande vatten när utrustningens rörliga delar inte är i rörelse.

1.6 Kylvätska

1.6.1 Personskydd



Produkten är farlig att förtära.
Kan irritera ögon, slemhinnor och hud.



Använd gummihandskar för att undvika direktkontakt med produkten.



Använd skyddsglasögon för att undvika stänk i ögonen.



Använd normala arbetskläder för att undvika hudkontakt.

1.6.2 Jåtmekåitlus



Bortskaffa inte elutrustningen tillsammans med vanligt avfall!

I enlighet med direktiv 2012/19/EU om avfall som utgörs av eller innehåller elektrisk och elektronisk utrustning och bestämmelserna om dess införlivande med nationell lagstiftning ska uttjänad elutrustning samlas in separat och lämnas till en samlings- och återvinningscentral. Utrustningens ägare ska vända sig till kommunen för att identifiera de auktoriserade samlingscentralerna. Tillämpningen av EU-direktivet kommer att bidra till att förbättra miljön och människors hälsa.



När produkten har använts för sitt ändamål ska spill eller rester behandlas i lämplig reningsanläggning eller om möjligt återanvändas. Använd produkt får inte tömmas ut i vattendrag, diken eller avloppssystem. Utspädd vätska får inte tömmas ut i avloppet om detta inte är tillåtet enligt lokala bestämmelser.

2. INSTALLATION

2.1 Lyftning, transport och lossning

- Aggregatet har inga särskilda lyftanordningar.



Undersökta inte aggregatets vikt, se tekniska data.

Förflytta eller stoppa inte lasten ovanför människor eller föremål.

Låt inte aggregatet eller en enskild enhet falla eller ställas ned med en kraftig stöt.

2.2 Aggregatets placering



Tillämpa följande kriterier:

- Kommandon och kopplingar ska vara lättillgängliga.
- Placera inte utrustningen i trånga utrymmen.
- Placera inte aggregatet på ett plan som lutar mer än 10° i relation till horisontalplanet.
- Placera aggregatet på torr, ren plats med god ventilation.
- Skydda aggregatet mot regn och direkt solljus.
- » Se avsnittet "Försiktighetsåtgärder vid användning av gasbehållare".

2.3 Inkoppling



Stäng av strömförsörjningen till aggregatet före alla ingrepp!

2.4 Igångsättning

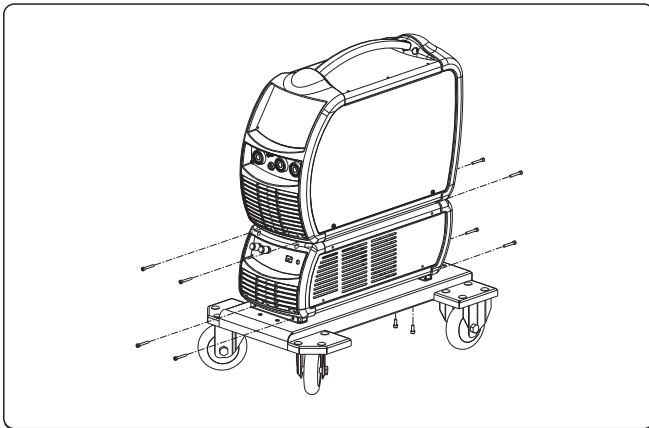

- Placera WU ovanpå GT och fäst den med de 4 skruvarna.
- Placera generatoren på kylvheten och fäst den med skruvarna.

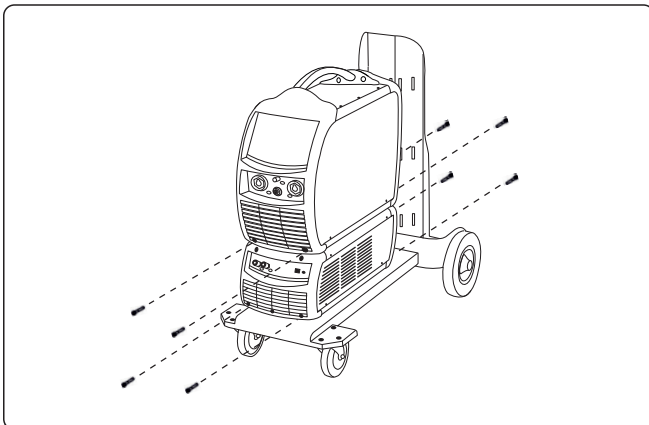

- Placera WU ovanpå GT och fäst den med de 4 skruvarna.
- Placera generatoren på kylvheten och fäst den med skruvarna.

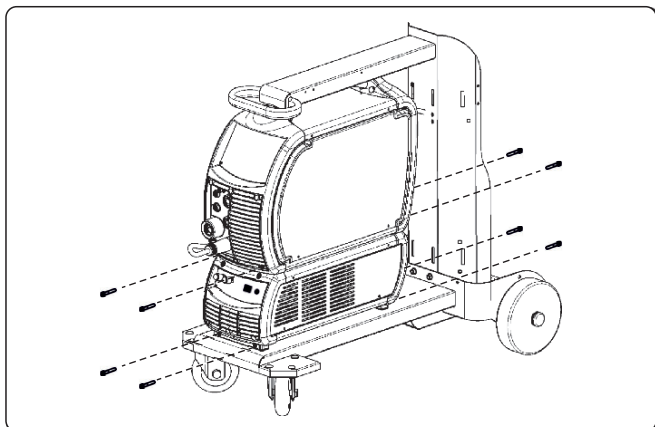

- ▶ Placera WU ovanpå GT och fäst den med de 4 skruvarna.
- ▶ Placera generatorn på kylvätskheten och fäst den med skruvarna.

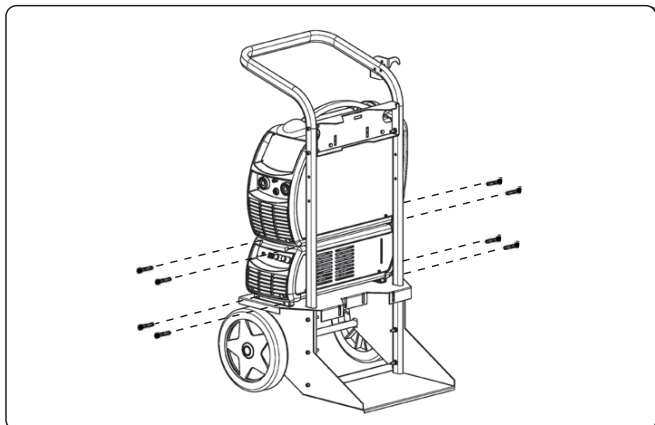

- ▶ Placera WU ovanpå GT och fäst den med de 4 skruvarna.
- ▶ Placera generatorn på kylvätskheten och fäst den med skruvarna.



Innan du sätter igång enheten:

- ▶ Ta loss proppen från behållaren.
- ▶ Ta loss den lufttöta proppen ur intagskanalen genom att bända längs kanten av proppen med ett verktyg.
- ▶ Fyll vid behov på vätska i behållaren.
- ▶ Ta vara på den lufttöta proppen för den händelse att enheten ska transporteras i framtiden.



Montera alltid förbiledningslangan när brännaren inte är ansluten till in- och utgångarna för kylvätska för att inte skada kylvätskheten.



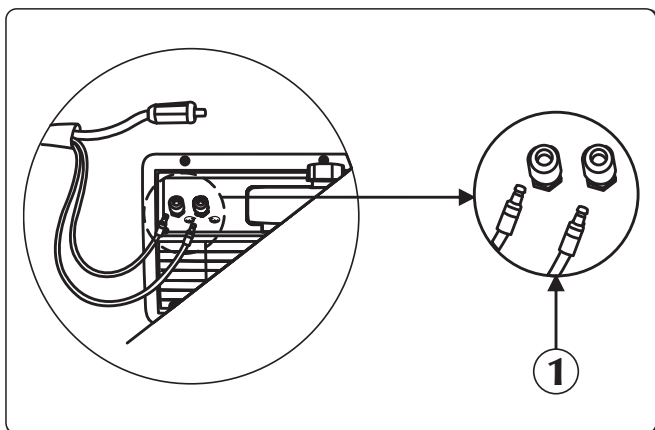

Vid påfyllning av behållaren ska kylvätska med art.nr 18.91.008 användas.

2.4.1 Anslutning till bakpanel





① Kylvätskans inlopp/utlopp

- ▶ Anslut matarslangen för kylvätska i ledningsknippet (blå) till kopplingen (blå - symbol ).
- ▶ Anslut returslangen för kylvätska i ledningsknippet (röd) till kopplingen (röd - symbol ).

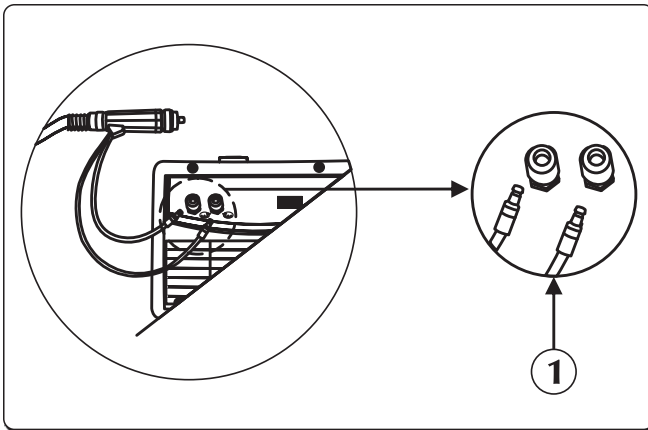
2.4.2 Anslutning till frontpanel



① Kylvätskans inlopp/utlopp

- ▶ Anslut matarslangen för kylvätska till brännaren (blå) till kopplingen (blå - symbol ).
- ▶ Anslut returslangen för kylvätska från brännaren (röd) till kopplingen (röd - symbol .

3. BESKRIVNING AV AGGREGATET

3.1 Bakre kontrollpanel

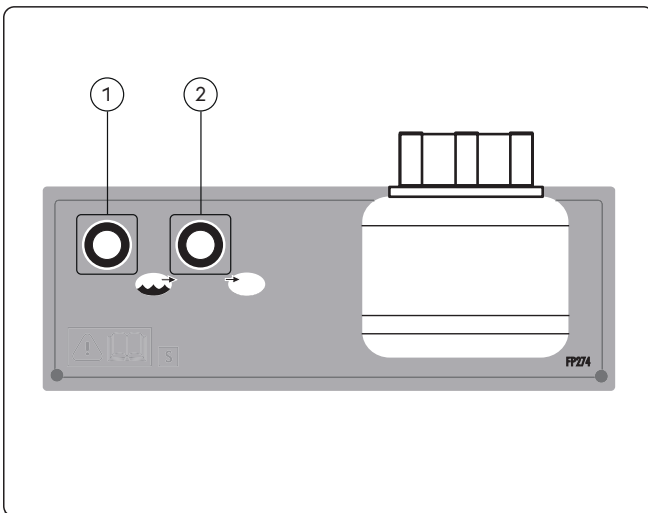

① Koppling för kylvätskeutlopp

Används för att föra in vätska med låg temperatur i brännarens kylkrets.

② Koppling för kylvätskeinlopp

Används för att föra in vätska som har värmts upp av brännaren i WUs kylkrets.

3.2 Främre kontrollpanel

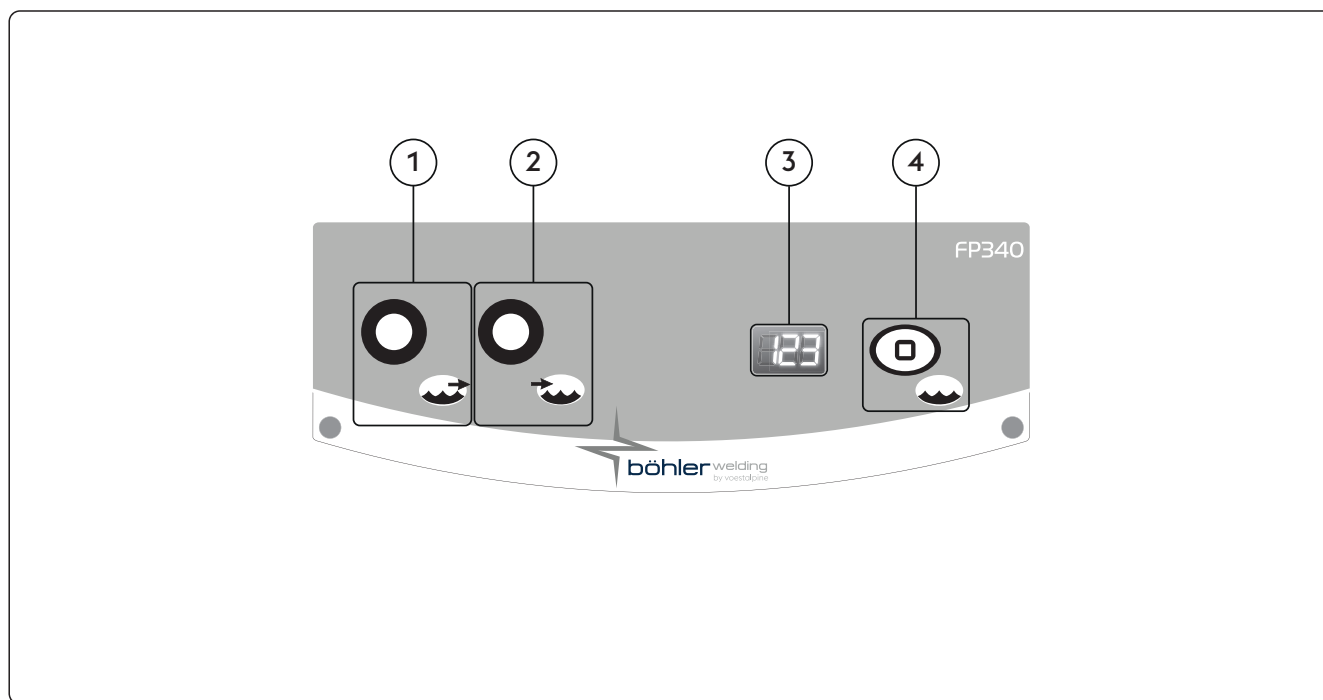

- 1 **Koppling för kylvätskeutlopp**
 Används för att föra in vätska med låg temperatur i brännarens kylkrets.
- 2 **Koppling för kylvätskeinlopp**
 Används för att föra in vätska som har värmts upp av brännaren i WUs kylkrets.
- 3 **Display med 7 segment**
 Gör att man kan visa allmänna parametrar för WU under start, att den fungerar som den ska samt kylvätskans inre temperatur.
 -- Kylenheten avaktiverad.
- 4 **Test av kylenheten**

SV

4. UNDERHÅLL



Anläggningen ska genomgå löpande underhåll i enlighet med tillverkarens instruktioner. Alla luckor och kåpor ska vara stängda och ordentligt fastsatta när apparaten är i drift. Aggregatet får inte modifieras på något sätt. Om detta underhåll inte utförs upphör alla garantier att gälla och tillverkaren kan inte utkrävas något ansvar för konsekvenserna.



Eventuellt underhåll får endast utföras av utbildad personal. Om obehörig personal reparerar aggregatet eller byter ut delar av det upphör produktgarantin omedelbart att gälla. Eventuella reparationer och utbyte av delar av aggregatet får endast utföras av kompetent teknisk personal.



Stäng av strömförsörjningen till aggregatet före alla ingrepp!

4.1 Periodiska kontroller av generatorm



Kontrollera kylvätskenivån i behållaren med jämna mellanrum. Om behållaren töms helt och/eller om det finns luft i pumpen kan det hända att pumpen inte startar.

- Rengör generatorm invändigt med tryckluft med lågt tryck och pensel med mjuk borst.
- Kontrollera de elektriska anslutningarna och alla kabelkopplingar.
- Kontrollera motorpumpens skick.
- Kontrollera slanganslutningarna.

Byt kylvätska en gång i halvåret och spola slangarna och behållaren med vatten. Byt kylvätska om den skulle koka, eftersom den då förlorar sina skyddande egenskaper.



Påfyllning av kylvätska i behållaren ska göras när generatoren och WU är ihopmonterade och står på ett horisontellt plan.



Vid påfyllning av behållaren ska kylvätska med art.nr 18.91.008 användas. Använd inte utrustningen utan kylvätska.



Använd inte ledande kylvätska.



Rengör generatoren invändigt med tryckluft med lågt tryck och pensel med mjuk borst. Kontrollera de elektriska anslutningarna och alla kabelkopplingar.

4.2 Odpowiedzialność



Om detta underhåll inte utförs upphör alla garantier att gälla och tillverkaren kan inte utkrävas något ansvar för konsekvenserna. Tillverkaren påtar sig inget ansvar om operatören inte följer dessa anvisningar. Kontakta närmaste serviceverkstad vid tveksamheter och/eller problem.

5. LARMKODER



LARM















Om ett larm utlöses eller en kritisk övervakningsgräns överskrids visas en ljussignalering på kontrollpanelen och svetsningen blockeras omedelbart.



OBS

Om en larmgräns överskrids visas en ljussignalering på kontrollpanelen men svetsningen behöver inte avbrytas.

Nedan listas samtliga larm och övervakningsgränser för systemet.

 E43	Saknas kylvätska		 E71	Överhettad kylvätska	
 E76	Överskriden flödesnivå för kylvätska		 E77	Temperaturnivå för kylvätska	
 E81	Överström (pump WU)		 E82	Kommunikationsfel (WU)	
 E83	Blockerad pump				

SV

6. FELSÖKNING OCH TIPS

Flöde saknas i kretsen

Orsak

- » Vätskebrist i behållaren.
- » Luft i kylkretsen.

Lösning

- » Fyll på med vätska.
- » Koppla förbikopplingsledningen till utloppsanslutningen (blå) och lufta hydraulkretsen så att kylvätskan kommer fram några sekunder.

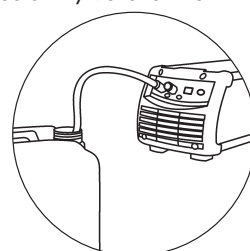

» Kylkretsen blockerad eller trasig.

- » Kontrollera anslutningarnas skick (inuti enheten) i hydraulkretsen.
- » Kontrollera brännarens hydraulkrets.
- » Kontrollera kylkretsens status i kabelknippet.
- » Kontakta närmaste serviceverkstad för reparation av aggregatet.

» Kylenhetslarmet aktiverat.

- » Återställ larmet.
- » Anslut en brännare eller förbikopplingsledning i de funktionslägen där kylvatten måste vara aktiv.
- » Kontrollera anslutningarnas skick (inuti enheten) i hydraulkretsen.
- » Kontrollera brännarens hydraulkrets.
- » Kontakta närmaste serviceverkstad för reparation av aggregatet.

» Trasig pump.

- » Byt ut den skadade komponenten.
- » Kontakta närmaste serviceverkstad för reparation av aggregatet.

Otillräcklig kylkapacitet

Orsak

- » Trasig fläkt.
- » Trasig pump.







Lösning

- » Byt ut den skadade komponenten.
- » Kontakta närmaste serviceverkstad för reparation av aggregatet.
- » Byt ut den skadade komponenten.
- » Kontakta närmaste serviceverkstad för reparation av aggregatet.





7. TEKNISKA DATA

Elektriska egenskaper		U.M.
Nätspänning U1	360	Vdc
Maximal strömförbrukning I1max	0.4	A
Kylkraft (25 °C)	1000	W
Fysiska egenskaper		U.M.
IP-skyddsgrad	IP23S	
Mått (lxbxh)	660x240x220	mm
Vikt	12.0	Kg
Typ av värmväxlare	H ₂ O - Luft	
Nominell kapacitet (QV)	2.3	l/min
Maximikapacitet pump (Qvmax)	4.6	l/min
Uppfordring pump (Hmax)	35	m
Typ av pump	Rotationspump	
Maximalt varvtal	3300	RPM
Behållarens kapacitet	3.0	l
Konstruktionsbestämmelser	EN IEC 60974-2:2019 EN 60974-10/A1:2015	

8. MÄRKPLÅT

 VOESTALPINE BÖHLER WELDING ARC TECHNOLOGY S.R.L. Via Palladio, 19 - ONARA (PADOVA) - ITALY		
WU 2000		N°
EN IEC	60974-2:2019 60974-10/A1:2015 Class A	
Energy input		
	U ₁ 350V	I _{1max} 0.35A
	IP 23 S	
Liquid cooling system		
	P _{11/min} 1.0kW	P _{max} 0.35MPa (3.5bar)
		  
	MADE IN ITALY	

9. MÄRKPLÅTENS INNEBÖRD

1		2	
3		4	
5			
6			
6	7	8	
	9		
10			
10	11	12	
		  	
	MADE IN ITALY		

- 1 Fabrikat
- 2 Tillverkarens namn och adress
- 3 Apparatens modell
- 4 Serienummer
- XXXXXXXXXXXXX Tillverkningsår
- 5 Hänvisning till tillverkningsstandarder
- 6 Symbol för nätanslutning
- 7 Nominell matningsspänning
- 8 Max. nominell matningsström
- 9 Kapslingsklass
- 10 Symbol för kylsystem
- 11 Kylkraft
- 12 Maximalt tryck

CE EU-försäkran om överensstämmelse
 EAC EAC-försäkran om överensstämmelse
 UKCA UKCA-försäkran om överensstämmelse

EU-OVERENSSTEMMELSESERKLÆRING

Byggeren
voestalpine Böhler Welding Arc Technology S.r.l.
Via Palladio, 19 - 35019 Onara di Tombolo (PD) - ITALY
Tel. +39 049 9413/111 - Fax +39 049 9413/311 - www.voestalpine.com/welding

erklærer under eget ansvar, at det følgende produkt:

WU 2000

71.03.076

er i overensstemmelse med følgende EU-direktiver:

2014/35/EU LOW VOLTAGE DIRECTIVE

2014/30/EU EMC DIRECTIVE

2011/65/EU RoHS DIRECTIVE

og at følgende harmoniserede standarder er anvendt:

EN IEC 60974-2:2019

LIQUID COOLING SYSTEMS

EN 60974-10/A1:2015

ELECTROMAGNETIC COMPATIBILITY REQUIREMENTS

Dokumentationen, der bekræfter overholdelse af direktiverne, holdes tilgængelig til inspektion hos den førnævnte producent.

Ethvert indgreb eller enhver ændring, der ikke er autoriseret af voestalpine Böhler Welding Arc Technology S.r.l., vil medføre, at denne erklæring ikke længere er gyldig.

Onara di Tombolo, 01/05/2025

voestalpine Böhler Welding Arc Technology S.r.l.



Mirco Frasson

Ivo Bonello

Managing Directors

DA

INDHOLDSFORTEGNELSE

1. ADVARSEL	103
1.1 Brugsomgivelser	103
1.2 Personlig beskyttelse og beskyttelse af andre	103
1.3 Beskyttelse mod elektrisk stød	103
1.4 Elektromagnetiske felter og forstyrrelser	104
1.5 IP-beskyttelsesgrad	104
1.6 Kølevæske.....	104
2. INSTALLERING	105
2.1 Løfte-, transport- og aflæsningsanvisninger.....	105
2.2 Placering af anlægget.....	105
2.3 Tilslutning	105
2.4 Idriftsættelse.....	105
3. PRÆSENTATION AF ANLÆGGET	107
3.1 Bagpanel	107
3.2 Frontbetjeningspanel	108
4. VEDLIGEHOLDELSE	108
4.1 Regelmæssig kontrol af strømkilden.....	108
4.2 Vastuu	109
5. ALARMKODER	109
6. FEJLFINDING OG LØSNINGER	109
7. TEKNISKE SPECIFIKATIONER	110
8. DATASKILT	111
9. BETYDNING AF OPLYSNINGERNE DATASKILT	111
10. OVERSIGT.....	149
11. KONNEKTORER.....	150
12. RESERVEDELSLISTE.....	151

DA

SYMBOLER



Advarsel



Forbud



Forpligtelser



Generelle indikationer

1. ADVARSEL



Inden der udføres nogen form for indgreb, skal man have læst og forstået denne vejledning.

Der må ikke udføres ændringer på maskinen eller vedligeholdelse, der ikke er beskrevet i vejledningen. Fabrikanten påtager sig intet ansvar for legemsbeskadigelser eller beskadigelse af ting, opstået på grund af manglende læsning eller udførelse af indholdet i denne vejledning.

Opbevar altid brugsanvisningerne på apparatets brugssted. Overhold ikke blot brugsanvisningerne, men også de generelle forskrifter og de gældende lokale regler for forebyggelse af ulykker og miljøhensyn.

voestalpine Böhler Welding Arc Technology S.r.l. forbeholder sig ret til at foretage ændringer når som helst uden forudgående varsel.

Rettighederne til oversættelse, genoptrykning og redigering, enten hel eller delvis, med ethvert middel (inklusive fotokopier, film og mikrofilm) tilhører voestalpine Böhler Welding Arc Technology S.r.l. og er forbudt uden skriftlig tilladelse fra dette firma.

Disse anvisninger er af vital vigtighed og derfor nødvendige for garantiens opretholdelse.

Fabrikanten fralægger sig ethvert ansvar, hvis operatøren ikke overholder disse forskrifter.



Alle personer med ansvar for ibrugtagning, for brug, for vedligeholdelse og for reparation af apparatetskal

- besidde den relevante kvalifikation
- læse hele denne brugsvejledning og nøje følge anvisningerne.

Tag kontakt til en fagmand i tilfælde af tvivl eller problemer omkring anlæggets brug, også selvom problemet ikke omtales heri.

1.1 Brugsomgivelser



Ethvert anlæg må udelukkende benyttes til dets forudsete brug, på de måder og områder, der er anført på dataskiltet og/eller i denne vejledning, og i henhold til de nationale og internationale sikkerhedsforskrifter. Anden brug end den, fabrikanten udtrykkeligt har angivet, skal betragtes som uhensigtsmæssig og farlig og vil fritage fabrikanten for enhver form for ansvar for skade.



Dette apparat må udelukkende anvendes til professionelle formål i industrielle omgivelser. Fabrikanten fralægger sig ethvert ansvar for skader forårsaget af anlæggets brug i private omgivelser.



Anlægget skal anvendes i omgivelser med en temperatur på mellem -10°C og +40°C (mellem +14°F og +104°F).

Anlægget skal transporteres og opbevares i omgivelser med en temperatur på mellem -25°C og +55°C (mellem -13°F og 131°F).

Anlægget skal benyttes i omgivelser uden støv, syre, gas eller andre ætsende stoffer.

Anlægget skal benyttes i omgivelser med en relativ luftfugtighed på højst 50 % a 40°C (104°F).

Anlægget skal benyttes i omgivelser med en relativ luftfugtighed på højst 90 % ved 20°C (68°F).

Anlægget må ikke benyttes i en højde over havet på over 2000m (6500 fod).

1.2 Personlig beskyttelse og beskyttelse af andre



Kontrollér, at brænderen er kølet af, inden der udføres bearbejdnings eller vedligeholdelse.



Kontrollér, at kølegruppen er slukket, inden kølevæskens tilførsels- og afledningsslanger kobles fra. Den varme væske, der løber ud af rørene, vil kunne forårsage alvorlige skoldninger eller forbrændinger.



Sørg for, at der er førstehjælpsudstyr til rådighed.
Undervurder aldrig forbrændinger og sår.



Genopret sikre forhold i området, inden arbejdsområdet forlades, således at utilsigtet skade på personer og genstande undgås.

1.3 Beskyttelse mod elektrisk stød



Et elektrisk stød kan være dødbringende.

- Undgå berøring af strømførende dele både inden i og uden på svejseægget, så længe anlægget er under forsyning (brændere, tænger, jordforbindelseskabler, elektroder, ledninger, valser og spoler er elektrisk forbundet til svejsekredsløbet).
- Sørg for, at anlæg og elektrisk isoleret ved hjælp af tørre plader og sokler med tilstrækkelig isolering mod mulig jordforbindelse.

1.4 Elektromagnetiske felter og forstyrrelser

1.4.1 Klassificering EMC i overensstemmelse med: EN 60974-10/A1:2015.

Klasse
B

Udstyr i klasse B overholder kravene vedrørende elektromagnetisk kompatibilitet i industrielle miljøer og private boliger, herunder boligområder, hvor elektriciteten leveres via det offentlige lavspændingsforsyningsnet.

Klasse
A

Udstyr i klasse A er ikke beregnet til brug i boligområder, hvor elektriciteten leveres via det offentlige lavspændingsforsyningsnet. Der kan være visse vanskeligheder med at sikre elektromagnetisk kompatibilitet for klasse A-udstyr i sådanne områder på grund af ledningsbårne forstyrrelser og strålingsforstyrrelser.

For mere information, se kapitlet: DATASKILT eller TEKNISKE SPECIFIKATIONER.

1.4.2 Installering, brug og vurdering af området

Dette apparat er bygget i overensstemmelse med kravene i den harmoniserede standard EN 60974-10/A1:2015 og er identificeret som et "KLASSE A"-apparat. Dette apparat må udelukkende anvendes til professionelle formål i industrielle omgivelser. Fabrikanten fralægger sig ethvert ansvar for skader forårsaget af anlæggets brug i private omgivelser.



Brugeren skal have ekspertise indenfor arbejdsområdet, og han/hun er i denne henseende ansvarlig for installering og brug af apparatet i overensstemmelse med fabrikantens anvisninger. Hvis der opstår elektromagnetiske forstyrrelser, er det brugerens opgave at løse problemet med hjælp fra fabrikantens tekniske servicetjeneste.



Elektromagnetiske forstyrrelser skal under alle omstændigheder reduceres i en sådan grad, at de ikke længere har nogen indflydelse.



Inden dette apparat installeres, skal brugeren vurdere de eventuelle elektromagnetiske problemer, der kan opstå i det omkringliggende område, specielt hvad angår de tilstedeværende personers sundhedstilstand, fx: brugere af pacemakere og høreapparater.

1.4.3 Afskærmning

Afskærmning af udvalgte kabler og apparater i det omkringliggende område kan løse interferensproblemer. Muligheden for afskærmning af hele svejse-anlægget kan overvejes i specielle arbejdssituationer.

1.5 IP-beskyttelsesgrad

IP

IP23S

- Indkapslingen er beskyttet mod indføring af fingre og faste fremmedlegemer med en diameter større end/lig med 12,5 mm og berøring af farlige dele.
- Indkapslingen er beskyttet mod regn i en vinkel på op til 60° fra lodret position.
- Indkapslingen er beskyttet mod skader forårsaget af vandindtrængning, når apparaturets bevægelige dele ikke er i bevægelse.

1.6 Kølevæske

1.6.1 Personbeskyttelse



Helbredsskadelig ved indtagelse.
Kan forårsage irritation på øjne, slimhinder og hud.



Undgå berøring, benyt gummihandsker.



Forebyg stænk, benyt sikkerhedsbriller.



Undgå berøring med huden, anvend almindeligt arbejdstøj.

1.6.2 Bortskaffelse



Apparatet må ikke bortskaffes med normalt affald.

I overensstemmelse med det europæiske direktiv 2012/19/EU om affald af elektrisk og elektronisk udstyr og dets implementering i overensstemmelse med national lovgivning skal elektrisk udstyr, der er udtjent, indsamles separat og sendes til nyttiggørelse og bortskaffelse. Ejeren af udstyret skal identificere de autoriserede indsamlingscentre ved at forhøre sig hos kommunen. Anvendelsen af det europæiske direktiv vil forbedre miljøet og menneskers sundhed.



Efter at produktet har været anvendt indenfor det forudsete brugsområde, skal udslip eller rester behandles på et rensningsanlæg eller, om muligt, indgå i en genbrugscyklus. Det er ikke tilladt at udlede det brugte produkt i vandløb, grøfter eller bortledningssystemer. Fortyndet væske bør aldrig bortledes gennem kloaksystemet, med mindre dette er tilladt i de lokale forskrifter.

2. INSTALLERING

2.1 Løfte-, transport- og aflæsningsanvisninger

- Anlægget er ikke udstyret med specielle løfteelementer.



Undervurder aldrig anlæggets vægt, (læs de tekniske specifikationer).

Lad aldrig læsset glide hen over - eller hænge stille over - mennesker eller ting.

Lad aldrig anlægget eller de enkelte enheder falde eller støtte mod jordoverfladen med stor kraft.

2.2 Placering af anlægget



Overhold nedenstående forholdsregler:

- Der skal være nem adgang til betjeningsorganerne og tilslutningspunkterne.
- Placér aldrig udstyret i snævre områder.
- Anbring aldrig anlægget på en overflade med en hældning på over 10° i forhold til det vandrette plan.
- Slut anlægget til i et tørt, rent område med god udluftning.
- Beskyt anlægget mod direkte regn og solstråler.
- » Se under "Forholdsregler ved brug af gasflasker".

2.3 Tilslutning



Afbryd strømforsyningen til anlægget inden enhver form for indgreb!

2.4 Idriftsættelse

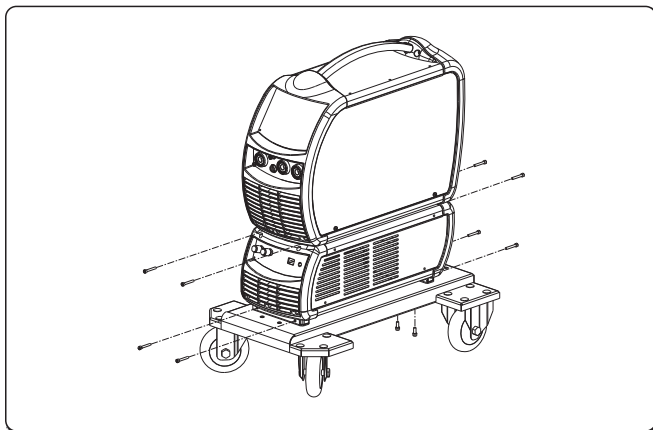

- ▶ Placer WU over GT og fastgør med de 4 skruer.
- ▶ Placer generatoren oven på kølegruppen og fastgør med de relevante skruer.

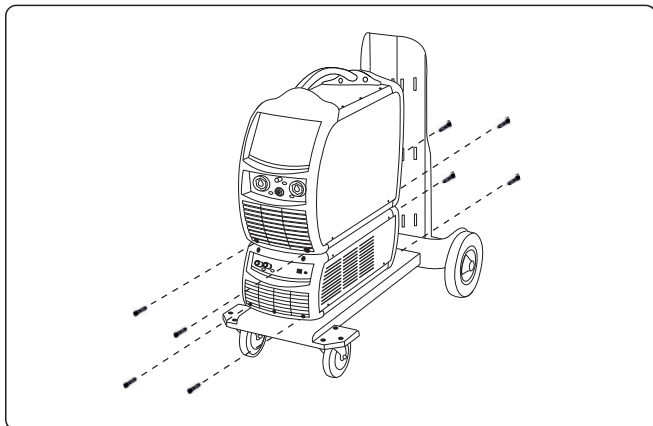

- ▶ Placer WU over GT og fastgør med de 4 skruer.
- ▶ Placer generatoren oven på kølegruppen og fastgør med de relevante skruer.

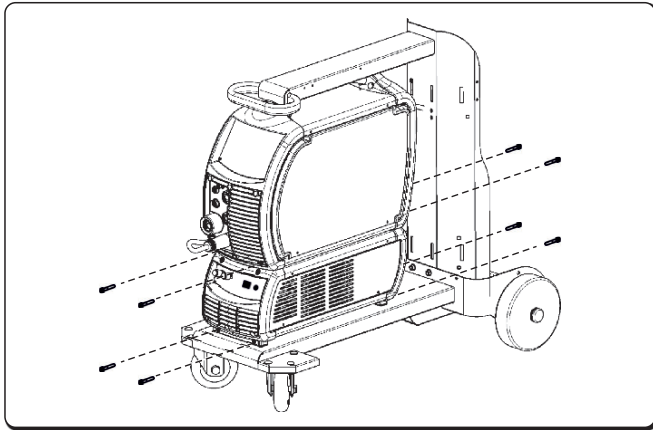

- ▶ Placer WU over GT og fastgør med de 4 skruer.
- ▶ Placer generatoren oven på kølegruppen og fastgør med de relevante skruer.

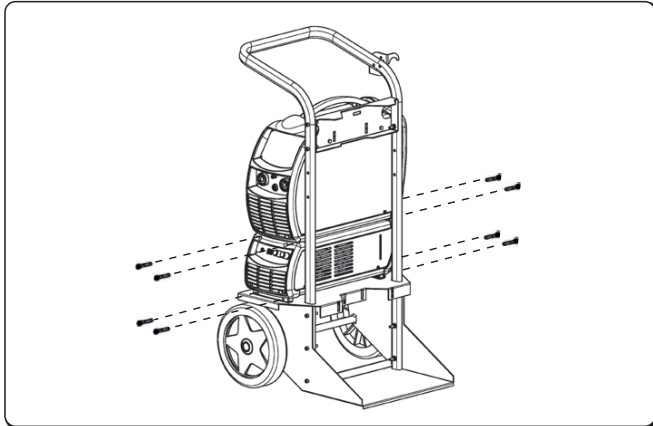

- ▶ Placer WU over GT og fastgør med de 4 skruer.
- ▶ Placer generatoren oven på kølegruppen og fastgør med de relevante skruer.



Inden enheden sættes i funktion, skal man udføre følgende handlinger:

- ▶ Fjern lukkeproppen fra tanken.
- ▶ Fjern proppen med hermetisk lukning fra påfyldningskanalen ved at skubbe opad med et stykke værktøj på proppens kant.
- ▶ Fyld om nødvendigt væske i tanken.
- ▶ Opbevar proppen med hermetisk lukning til eventuelle fremtidige flytninger af enheden.



For ikke at beskadige afkølingsenheden skal man altid montere by-pass-røret, når brænderen ikke er tilsluttet terminalerne for indgang/udgang for kølevæsken.



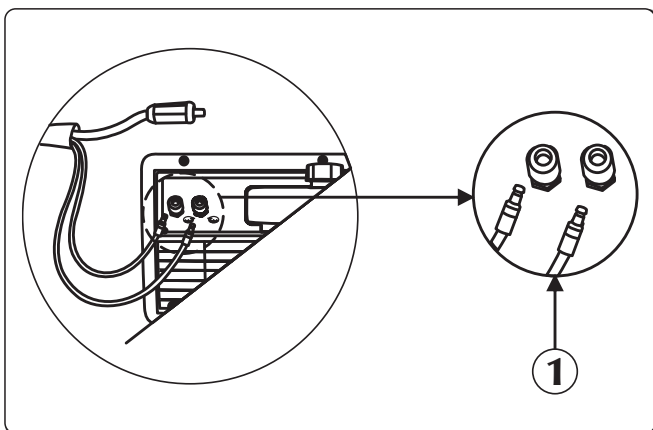

Påfyldning eller genopfyldning af tanken skal udføres med kølevæsken kode 18.91.008.

2.4.1 Tilslutning på bagpanel





① Indgang/udgang kølevæske.

- ▶ Forbind kabelbundtets kølevæsketilførselsslange (blå farve) med det relevante samlestykke/kobling (blå farve - symbol ).
- ▶ Forbind kabelbundtets kølevæsketilbageløbsslange (rød farve) med det relevante samlestykke/kobling (rød farve - symbol .

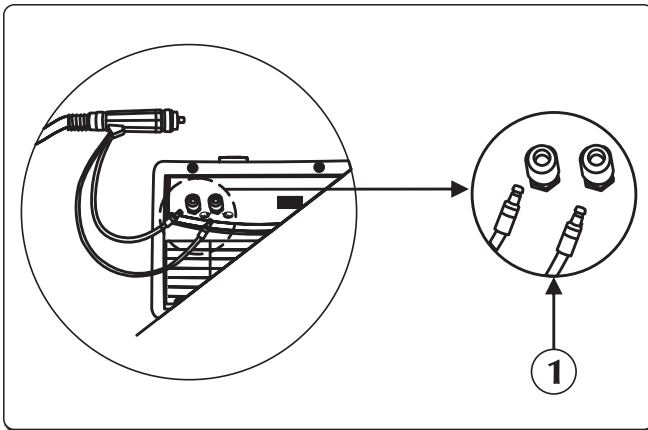
2.4.2 Tilslutning på frontpanel



① Indgang/udgang kølevæske.

- ▶ Forbind brænderens kølevæsketilførselsslange (blå farve) med det relevante samlestykke/kobling (blå farve - symbol ).
- ▶ Forbind brænderens kølevæsketilbageførselsslange (rød farve) med det relevante samlestykke/kobling (rød farve - symbol ).

3. PRÆSENTATION AF ANLÆGGET

3.1 Bagpanel

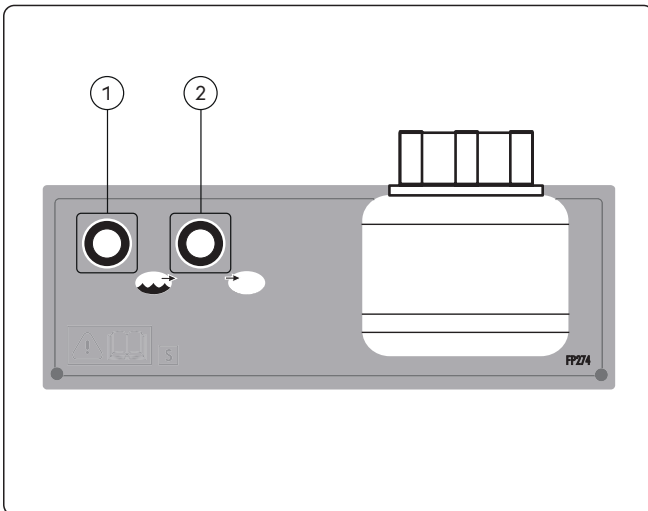

① Udløbskobling for kølevæske





Gør det muligt at indsprøjte væske med lav temperatur i svejsebrænderens kølekredsløb.

② Indtagkobling for kølevæske

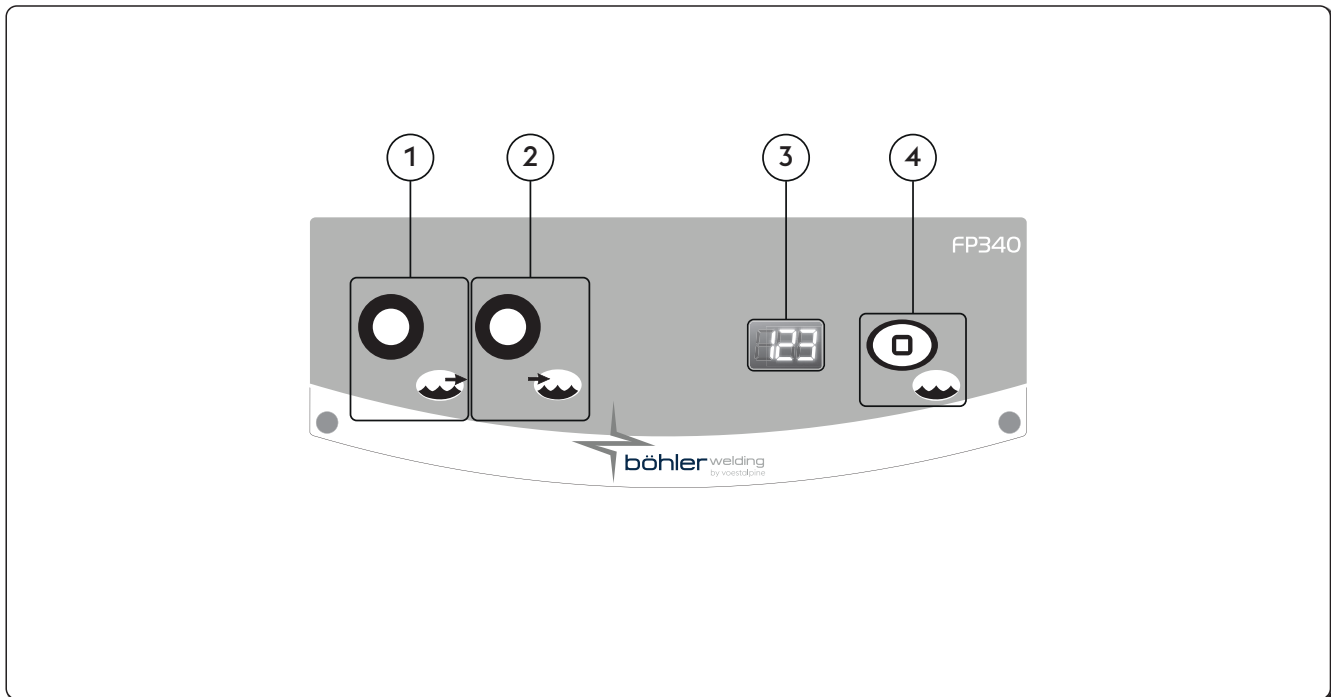

Gør det muligt at indsprøjte væske, som er blevet opvarmet af svejsebrænderen, i kølekredsløbet i WU.

3.2 Frontbetjeningspanel



- 1  **Udløbskobling for kølevæske**
Gør det muligt at indsprøjte væske med lav temperatur i svejsebrænderens kølekredsløb.
- 2  **Indtagskobling for kølevæske**
Gør det muligt at indsprøjte væske, som er blevet opvarmet af svejsebrænderen, i kølekredsløbet i WU.
- 3  **7-segment display**
Tillader at vise WU's specifikationer i startfasen, dens korrekte funktion og kølevæskens indvendige temperatur.
-- Deaktiveret køleenhed.
- 4  **Test af kølegruppe**

4. VEDLIGEHOEDElse

-  Anlægget skal undergå en rutinemæssig vedligeholdelse i henhold til fabrikantens anvisninger. Alle adgangslåger, åbninger og dæksler skal være lukket og korrekt fastgjort, når apparatet er i funktion. Der må aldrig udføres nogen form for ændringer på anlægget. Undgå ophobning af metalstøv i nærheden af eller direkte på udluftningsvingerne.
-  Al vedligeholdelse skal udelukkende udføres af kvalificeret personale. Reparation eller udskiftning af anlægselementer udført af uautoriseret personale medfører øjeblikkeligt bortfald af produktgarantien. Eventuel reparation eller udskiftning af anlægselementer må udelukkende udføres af teknisk kvalificeret personale.



Afbryd strømforsyningen til anlægget inden enhver form for indgreb!

4.1 Regelmæssig kontrol af strømkilden

-  Kølervæskenniveauet skal kontrolleres regelmæssigt. Hvis beholderen er tom, eller hvis der er luft i kølekredsløbet, vil pumpen ikke opnå tilstrækkelig sugkraft.

- Rengør strømkilden indvendigt ved hjælp af trykluft med lavt tryk og bløde børster.
- Kontrollér de elektriske tilslutninger og alle forbindelseskablerne.
- Kontroller elektropumpens tilstand.
- Kontroller rørledningstilslutningernes tilstand.

Hvert halve år skal man skifte kølevæsken og skylle rørene og tanken med vand. Skift væsken, hvis den skulle komme i kog, fordi dette medfører tab af metalbeskyttelsesegenskaberne.



Påfyldning eller genopfyldning af tanken med kølevæske skal udføres med generatoren og WU samlet og anbragt på en vandret overflade.



Påfyldning eller genopfyldning af tanken skal udføres med kølevæsken kode 18.91.008. Udstyret må ikke anvendes uden kølevæske.



Benyt aldrig ledende kølevæsker.



Rengør strømkilden indvendigt ved hjælp af trykluft med lavt tryk og bløde børster. Kontrollér de elektriske tilslutninger og alle forbindelseskabler.

4.2 Vastuu



Ved manglende udførelse af ovennævnte vedligeholdelse vil alle garantier bortfalde, og fabrikanten vil i alle tilfælde være fritaget for alle former for ansvar. Fabrikanten fralægger sig ethvert ansvar, hvis operatøren ikke overholder disse forskrifter. Ret henvendelse til det nærmeste servicecenter ved enhver tvivl og/eller ethvert problem.

5. ALARMKODER



ALARM















Indgriben fra en alarm eller overskridelsen af en kritisk beskyttelsesgrænse forårsager et visuelt signal på kontrolpanelet og den øjeblikkelige blokering af svejsningen.



PAS PÅ

Overskridning af en beskyttelsesgrænse medfører en visualisering af en signalering på kontrolpanelet, men tillader at fortsætte svejsehandlingerne.

Alle alarmer og alle beskyttelsesgrænser for systemet er angivet nedenfor.

 E43	Kølevæskemangel		 E71	Kølevæskeovertemperatur	
 E76	Overskredet kølevæskeflowniveau		 E77	Kølevæsketemperaturniveau	
 E81	Overstrøm (WU-pumpe)		 E82	Kommunikationsfejl (WU)	
 E83	Blokeret Pumpe				

6. FEJLFINDING OG LØSNINGER

Manglende flow i kredsløb

Årsag

- » Mangel på væske i tanken.
- » Luft i kølekredsløbet.

Løsning

- » Efterfyld.
- » Indsæt shunten på udgangskoblingen (blå) og udluft hydraulikkredsløbet, hvorved kølevæskens udgang gøres mulig i nogle sekunder.

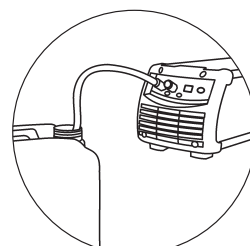

» Kølekredsløbet er tilstoppet eller afbrudt.

- » Kontrollér tilslutningernes stand (indvendig i enheden) i hydraulikkredsløbet.
- » Kontrollér standen af brænderens hydraulikkredsløb.
- » Tjek tilstanden ved kabelbundtets hydrauliske kredsløb.
- » Kontakt nærmeste servicecenter og lad anlægget reparere.

» Alarm i køleenheden.

- » Nulstil alarmen.
- » Tilslut en brænder eller shunten i de funktionsmåder, hvor køleenheden er i aktivitet.
- » Kontrollér tilslutningernes stand (indvendig i enheden) i hydraulikkredsløbet.
- » Kontrollér standen af brænderens hydraulikkredsløb.
- » Kontakt nærmeste servicecenter og lad anlægget reparere.

» Defekt pumpe.

- » Udskift den defekte komponent.
- » Kontakt nærmeste servicecenter og lad anlægget reparere.

Utilstrækkelig køleevne

Årsag

- » Defekt blæser.
- » Defekt pumpe.

Løsning







- » Udskift den defekte komponent.
- » Kontakt nærmeste servicecenter og lad anlægget reparere.
- » Udskift den defekte komponent.
- » Kontakt nærmeste servicecenter og lad anlægget reparere.

7. TEKNISKE SPECIFIKATIONER





Elektriske egenskaber		U.M.
Forsyningsspænding U1	360	Vdc
Maks. strøm optaget I1maks.	0.4	A
Køleeffekt (25°C)	1000	W
Fysiske egenskaber		U.M.
IP-beskyttelsesgrad	IP23S	
Dimensioner (lxdxh)	660x240x220	mm
Vægt	12.0	Kg
Varmevekslertype	H ₂ O - Luft	
Nominel kapacitet (QV)	2.3	l/min
Maksimal pumpekapacitet (Qvmax)	4.6	l/min
Pumpeløftehøjde (Hmax)	35	m
Pumpetype	Rotor	
Maksimalt omdrejningstal	3300	RPM
Tankkapacitet	3.0	l
Bygningsstandarder	EN IEC 60974-2:2019 EN 60974-10/A1:2015	

DA

8. DATASKILT

 VOESTALPINE BÖHLER WELDING ARC TECHNOLOGY S.R.L. Via Palladio, 19 - ONARA (PADOVA) - ITALY		
WU 2000		N°
EN IEC	60974-2:2019 60974-10/A1:2015 Class A	
Energy input		
	U ₁ 350V	I _{1max} 0.35A
	IP 23 S	
Liquid cooling system		
	P _{11/min} 1.0kW	P _{max} 0.35MPa (3.5bar)
  		
MADE IN ITALY 		

9. BETYDNING AF OPLYSNINGERNE DATASKILT

1		2	
3		4	
5			
6	7	8	
	9		
10	11	12	
  			
MADE IN ITALY 			

- 1 Fremstillingsmærke
- 2 Navn og adresse på producenten
- 3 Apparatets model
- 4 Serienummer
- 5 Henvielse til konstruktionsstandarder
- 6 Symbol for strømforsyning
- 7 Nominel forsyningspænding
- 8 Maksimal nominel strømforsyningsstrøm
- 9 Beskyttelsesgrad
- 10 Kølesystemsymbol
- 11 Køleeffekt
- 12 Maksimalt tryk

CE EU-overensstemmelseserklæring
 EAC EAC-overensstemmelseserklæring
 UKCA UKCA-overensstemmelseserklæring

EU-SAMSVARERKLÆRING

Byggherren
voestalpine Böhler Welding Arc Technology S.r.l.
Via Palladio, 19 - 35019 Onara di Tombolo (PD) - ITALY
Tel. +39 049 9413/111 - Fax +39 049 9413/311 - www.voestalpine.com/welding

erklærer under eget ansvar at følgende produkt:

WU 2000

71.03.076

er i samsvar med EU-direktivene:

2014/35/EU LOW VOLTAGE DIRECTIVE

2014/30/EU EMC DIRECTIVE

2011/65/EU RoHS DIRECTIVE

og at følgende harmoniserte standarder er anvendt:

EN IEC 60974-2:2019

LIQUID COOLING SYSTEMS

EN 60974-10/A1:2015

ELECTROMAGNETIC COMPATIBILITY REQUIREMENTS

Dokumentasjonen som bekrefter overholdelse av direktivene vil holdes tilgjengelig for inspeksjon hos den nevnte produsenten.

Ethvert inngrep eller forandring som ikke er autorisert av voestalpine Böhler Welding Arc Technology S.r.l. ugyldiggjør denne erklæringen.

Onara di Tombolo, 01/05/2025

voestalpine Böhler Welding Arc Technology S.r.l.



Mirco Frasson

Ivo Bonello

Managing Directors

INNHALDSFORTEGNELSE

1. ADVARSEL	115
1.1 Bruksmiljø.....	115
1.2 Personlig beskyttelse og beskyttelse av tredje mann	115
1.3 Vern mot elektrisk støt.....	115
1.4 Elektromagnetiske felt og forstyrrelser.....	116
1.5 Vernegrad IP	116
1.6 Kjølevæske.....	116
2. INSTALLASJON	117
2.1 Løfting, transport og lossing.....	117
2.2 Plassering av anlegget	117
2.3 Kopling.....	117
2.4 Installasjon.....	117
3. PRESENTASJON AV ANLEGGET	119
3.1 Bakpanel.....	119
3.2 Frontpanel med kontroller	120
4. VEDLIKEHOLD	120
4.1 Utfør følgende periodiske inngrep på generatoren.....	120
4.2 Sorumluluk.....	121
5. ALARM KODER	121
6. DIAGNOSTIKK OG LØSNINGER	121
7. TEKNISK SPESIFIKASJON	122
8. DATASKILT	123
9. BESKRIVELSE INFORMASJONSSKILT	123
10. SKJEMA	149
11. SKJØTEMUNNSTYKKER	150
12. LISTE OVER RESERVEDELER	151

NO

SYMBOLENES FORKLARING



Advarsel



Forbud



Forpliktelser



Generelle indikasjoner

1. ADVARSEL



Før du begynner operasjonene, må du forsikre deg om å ha lest og forstått denne håndboka.

Utførelse og modifikasjoner eller vedlikeholdsarbeid som ikke er beskrevet. Produsentene er ikke ansvarlig for skader på personer eller ting som oppstår på grunn av mangelfull forståelse eller manglende utførelse av instruksjonene i denne håndboka.

Bruksanvisningen skal alltid oppbevares der apparatet er i bruk. I tillegg til bruksanvisningen skal også generelle og lokale regler om ulykkesforebygging og miljø følges.

voestalpine Böhler Welding Arc Technology S.r.l. forbeholder seg retten til å foreta forandringer når som helst og uten forvarsel.

Rettighetene for oversettelser, reproduksjon, tilpasning, helt eller delvis og med ethvert middel (deri innbefattet fotokopier, film og mikrofilm) er reservert og forbudt uten skriftlig tillatelse av voestalpine Böhler Welding Arc Technology S.r.l.

Disse retningslinjer er meget viktige og nødvendige for garantiens gyldighet.

Hvis operatøren ikke følger instruksene, frasier fabrikanten seg alt ansvar.



Alle personer som jobber med idriftsetting, betjening, vedlikehold og reparasjon av apparatet, skal:

- være tilsvarende kvalifisert
- ha lest hele bruksanvisningen og følge denne

Ved tvil og problemer om bruken av anlegget, skal du henvende deg til kvalifisert personell.

1.1 Bruksmiljø



Alt utstyr skal kun brukes for operasjoner som det er prosjektet til, på den måte og i områdene som er angitt på skiltet og/eller i denne håndboka, i samsvar med nasjonale og internasjonale direktiver om sikkerhet. Bruk som skiller seg fra bruksmønster angitt av fabrikanten er ikke egnet og kan være farlig; i et slikt tilfelle frasier fabrikanten seg alt ansvar.



Denne enheten må brukes kun i profesjonelle applikasjoner i industrimiljøer. Fabrikanten er ikke ansvarlig for skader som er forårsaket ved privat bruk av anlegget.



Anlegget skal brukes i miljøer med en temperatur mellom -10°C og $+40^{\circ}\text{C}$ (mellom $+14^{\circ}\text{F}$ og $+104^{\circ}\text{F}$).

Anlegget skal transporteres og oppbevares i miljøer med en temperatur mellom -25°C og $+55^{\circ}\text{C}$ (mellom -13°F og 131°F).

Anlegget skal brukes i miljøer fritt for støv, syre, gass eller andre etsende stoffer.

Anlegget må ikke brukes i miljøer med en luftfuktighet over 50% ved 40°C (104°F).

Anlegget må ikke brukes i miljøer med en luftfuktighet over 90% ved 20°C (68°F).

Anlegget må ikke brukes høyere enn 2000m over havet.

1.2 Personlig beskyttelse og beskyttelse av tredje mann



Forsikre deg om at sveisebrenneren er avkjølet før du utfører arbeid eller vedlikehold på den.



Forsikre deg om at kjøleaggregatet er slått av før du frakopler slanger for tilførsel og retur av kjølevæsken. Den varme væsken som kommer ut kan føre til alvorlige forbrenninger eller skålding.



Forsikre deg om at det finnes et førstehjelpskrin i nærheten.

Ikke undervurder forbrenninger eller sår.



Før du forlater arbeidsplassen, skal du forsikre deg om at sonen er sikker for å forhindre ulykker som kan føre til skader på utstyr eller personer.

1.3 Vern mot elektrisk støt



Et elektrisk støt kan være dødelig.

- Unngå å røre ved innvendige eller utvendige deler som er forsynt med strøm i sveise mens anlegget er slått på (sveisebrenner, tenger, jordledninger, elektroder, ledninger, ruller og spoler er elektrisk koplet til sveisekretsen).
- Forsikre deg om at anleggets og operatørens elektriske isolering er korrekt ved å bruke tørre steder og gulv som skal være tilstrekkelig isolert fra jord.

1.4 Elektromagnetiske felt og forstyrrelser

1.4.1 EMC overensstemmelse med: EN 60974-10/A1:2015.

Klasse
B

Utstyr klasse B er i overensstemmelse med elektromagnetiske kompatibilitetskrav i industriell og beboelsesmiljø, inkludert boligområder hvor den elektriske kraft er forsynt fra det offentlige lavspennings forsyningssystem.

Klasse
A

Utstyr klasse A er ikke ment for bruk i boligområder hvor den elektriske kraft er forsynt fra det offentlige lavspennings forsyningssystem. Det kan være potesielle vanskeligheter i å sikre elektromagnetisk kompatibilitet av utstyr klasse A i disse områder, på grunn av styrte såvel som utstrålte forstyrrelser.

For mer informasjon, se kapittelet: DATASKILT eller TEKNISK SPESIFIKASJON.

1.4.2 Installasjon, bruk og vurdering av området

Dette apparatet er konstruert i samsvar med kravene i den harmoniserte normen EN 60974-10/A1:2015 og er identifisert som "KLASSE A". Denne enheten må brukes kun i profesjonelle applikasjoner i industrimiljøer. Fabrikanten er ikke ansvarlig for skader som er forårsaket ved privat bruk av anlegget.



Brukeren må ha erfaringer i sektoren og er ansvarlig for installasjonen og bruken av enheten i overensstemmelse med fabrikantens anvisninger. Hvis elektromagnetiske forstyrrelser oppstår, er det brukeren som må løse problemet, om nødvendig ved hjelp av fabrikantens tekniske assistanse.



Uansett må de elektromagnetiske forstyrrelsene bli redusert slik at de ikke utgjør et problem.



Før du installerer denne enheten, må du ta i betraktning mulige elektromagnetiske problemer som kan oppstå i området og som kan være farlige for personene som er i området, f.eks. personer som bruker pace-maker eller høreapparater.

1.4.3 Skjerming

Skjerming av andre kabler og apparater i nærheten kan redusere problemet med forstyrrelser.

Skjerming av hele sveiseanlegget kan være nødvendig for spesielle applikasjoner.

1.5 Vernegrad IP

IP

IP23S

- Innhold som er beskyttet mot tilgang til farlige deler med fingrene og innføring av massive fremmedlegemer med en diameter som overstiger/er lik 12,5 mm.
- Innholdet er beskyttet mot regn i en skråvinkel på 60°.
- Innholdet er beskyttet mot skadelige effekter grunnet inntrenging av vann, når apparatets bevegelige deler ikke er igang.

1.6 Kjølervæske

1.6.1 Personvern



Produktet er farlig å få i seg.
Kan føre til irritasjoner i øynene, slimhinnene og huden.



Unngå all kontakt ved å bruke gummihansker.



Unngå sprut ved å bruke vernebriller.



Unngå kontakt med huden ved å bruke vanlige arbeidsklær.

1.6.2 Avhending



Ikke sluttbehandle apparatet som usortert kommunalt avfall!

I samsvar med EU-direktiv 2012/19/EU om avfall fra elektrisk og elektronisk utstyr og implementering av direktivet i samsvar med nasjonal lovgivning, skal elektrisk utstyr ved levetidens utløp innsamles separat og leveres inn til et innsamlingscenter. Eierne av utstyret må kontakte de lokale myndighetene for informasjon om nærmeste innsamlingscenter. Anvendelsen av EU-direktivet vil forbedre miljøet og menneskehelsen.



Eventuelle lekkasjer eller produktrester etter bruk, må behandles i eget rensesanlegg eller, hvis mulig, resirkuleres. Det er ikke tillatt å kaste brukte produkter i vassdrag, i grøfter eller dreneringssystemer. Uttynnet væsker må ikke tømmes i kloakkledningen, hvis dette ikke er tillatt i henhold til lokale forskrifter.

2. INSTALLASJON

2.1 Løfting, transport og lossing

- Anlegget er ikke utstyrt med spesifikke deler for løfting.



Ikke undervurder anleggets vekt, (se teknisk spesifikasjon).
Ikke la lasten bevegges eller henges over personer eller ting.
Ikke dropp eller belaste anlegget med unødvendig tyngde.

2.2 Plassering av anlegget



Følg disse reglene:

- Gi lett adgang til kontrollene og kontaktene.
 - Plasser ikke utstyret i trange rom.
 - Sett aldri anlegget på en flate med en skråning som overstiger 100 fall.
 - Plasser anlegget på en tørr og ren plass med tilstrekkelig ventilasjon.
 - Beskytt anlegget mot regn og sol.
- » Konsulter seksjon "Forebyggelse ved bruk av gassbeholder".

2.3 Kopling



Kutt strømtilførselen til anlegget før ethvert inngrep!

2.4 Installasjon

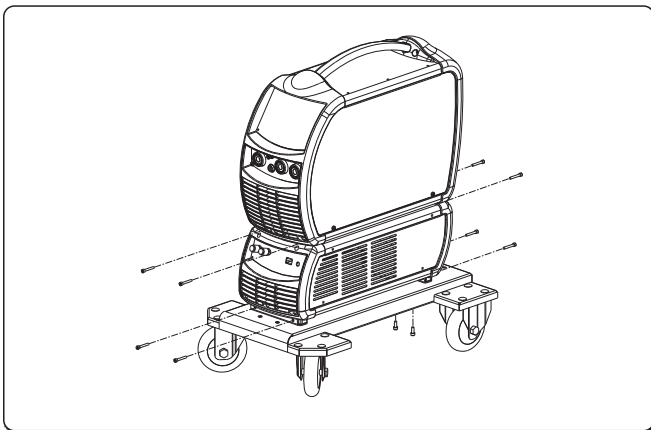

- ▶ Plasser WU på GT og fest den med 4 skruer.
- ▶ Plasser generatoren på kjøleanlegget og fest den med tilhørende skruer.

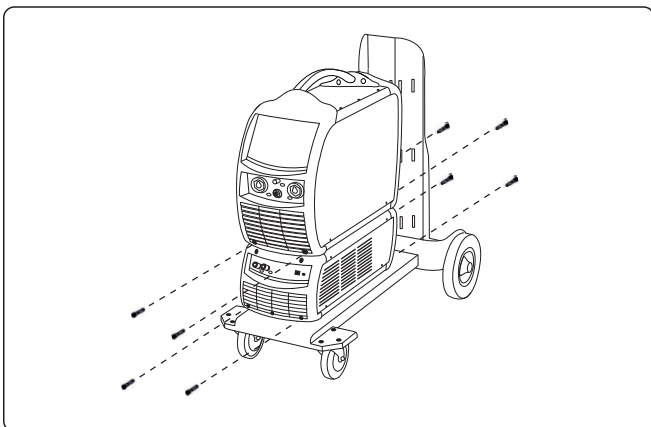

- ▶ Plasser WU på GT og fest den med 4 skruer.
- ▶ Plasser generatoren på kjøleanlegget og fest den med tilhørende skruer.

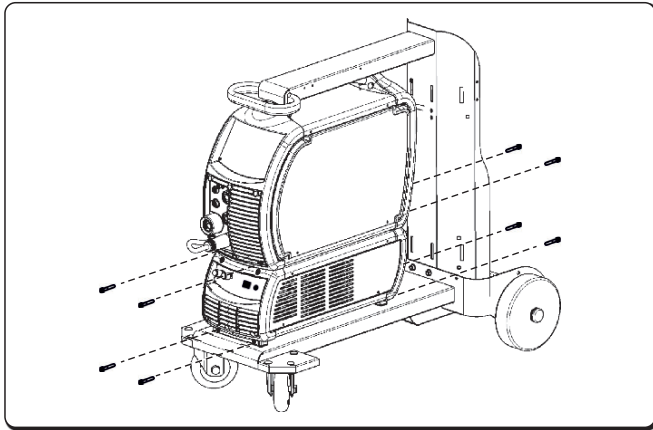

- ▶ Plasser WU på GT og fest den med 4 skruer.
- ▶ Plasser generatoren på kjøleanlegget og fest den med tilhørende skruer.

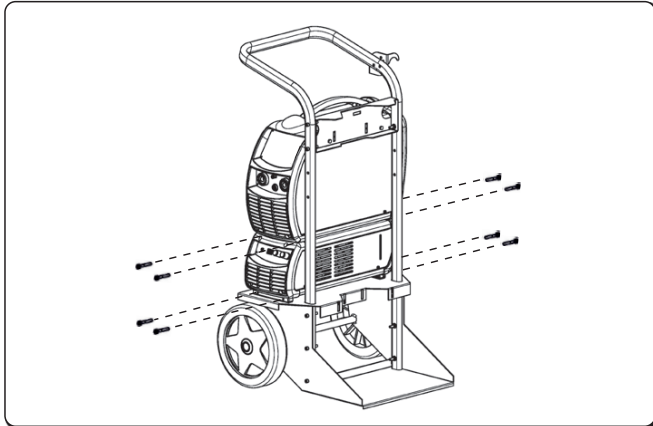

- ▶ Plasser WU på GT og fest den med 4 skruer.
- ▶ Plasser generatoren på kjøleanlegget og fest den med tilhørende skruer.



Utfør følgende operasjoner før du slår på enheten:

- ▶ Fjern tankens lokk.
- ▶ Fjern det hermetiske lokket fra påfyllingskanalen ved å vippe det av med et passende verktøy.
- ▶ Fyll kjølevæske på tanken hvis nødvendig.
- ▶ Ta vare på forseglingslokket for eventuell framtidig transport av enheten.



For å ikke skade kjøleanlegget, skal du alltid montere bypass-slangen når brenneren ikke er koplet til terminalene for inngang/utgang av kjølevæske.



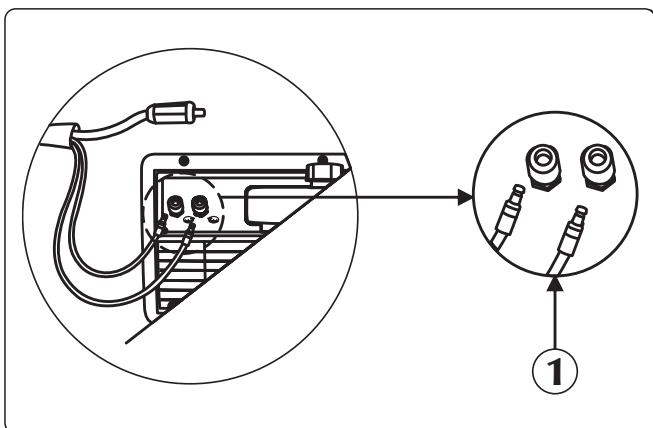

Påfylling eller etterfylling av tanken skal utføres med kjølevæske kode 18.91.008.

2.4.1 Tilkobling av bakpanel



① Kjølevæske inntak/uttak

- ▶ Kople vannslangen (blå farge) til hurtigkoplingsuttaket (blå farge ) på kjøleenheten.
- ▶ Kople vannslangen (rød farge) til hurtikoplings (rød farge ) inntak på kjøleenheten.

2.4.2 Tilkobling av frontpanel

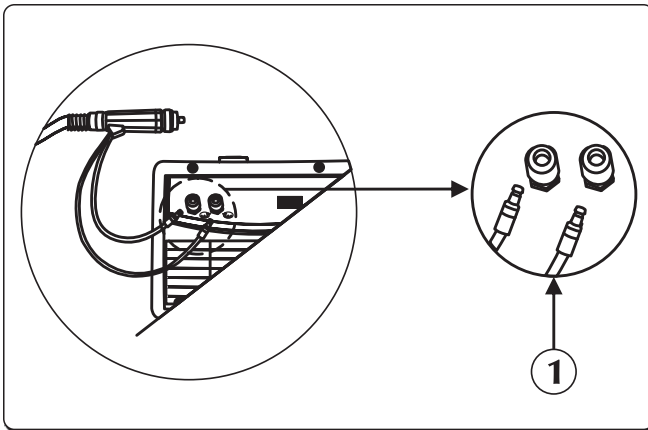

① Kjølevæske inntak/uttak

- ▶ Kople vannslangen fra sveisebrenneren (blå farge) til hurtigkoplings (blå farge) uttak på kjøleenheten.
- ▶ Kople vannslangen fra sveisebrenneren (rød farge) til hurtigkoplings (rød farge) inntak på kjøleenheten.

3. PRESENTASJON AV ANLEGGET

3.1 Bakpanel

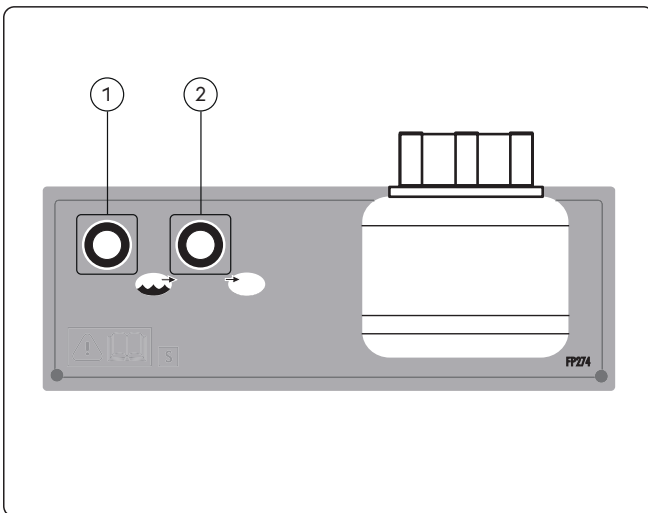

① Utløpskopling for kjølevæske





Kald væske føres inn i sveisebrennerens kjølekrets.

② Innløpskopling for kjølevæske

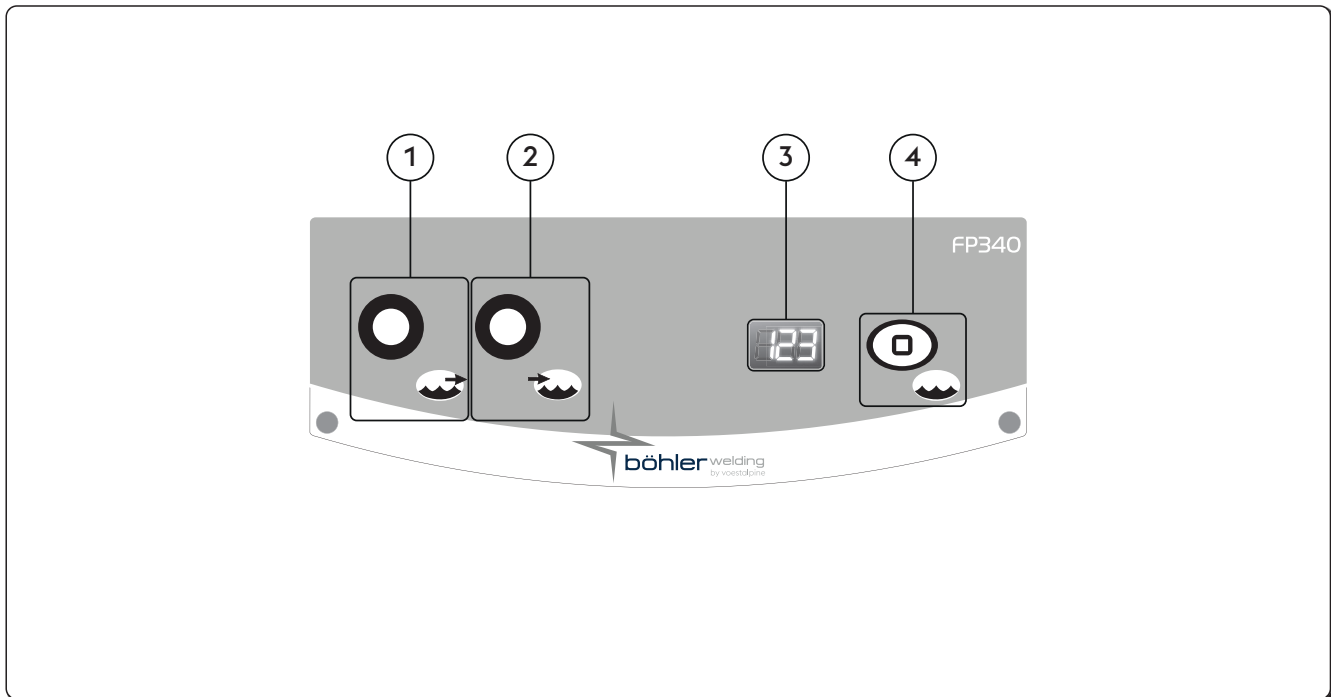

Væske som har blitt oppvarmet av sveisebrenneren føres inn i WU's interne kjølekrets.

3.2 Frontpanel med kontroller



- 
1 Utløpskopling for kjølevæske
 Kald væske føres inn i sveisebrennerens kjølekrets.
- 
2 Innløpskopling for kjølevæske
 Væske som har blitt oppvarmet av sveisebrenneren føres inn i WU's interne kjølekrets.
- 
3 7-segment skjerm
 Viser de generelle parameter av WU under oppstart, dennes korrekte operasjon og den interne temperatur av kjølevæsken.
 -- Kjøleenhet utkopleet.
- 
4 Test kjøleenhet

4. VEDLIKEHOLD

- 
 Du må utføre rutinemessig vedlikehold på anlegget i samsvar med fabrikantens instruksjoner. Alle adgangsdører, vedlikeholdsdører og deksel må være lukket og sitte godt fast når utstyret er igang. Du skal ikke utføre endringer på anlegget. Unngå at det hopper seg opp metallstøv nær eller på selve lufteribbene.
- 
 Alt vedlikeholdsarbeid må utføres kun av kvalifisert personell. Reparasjoner eller utskifting av deler på anlegget av personell som ikke er autorisert, betyr en umiddelbar annullering av produktets garanti. Eventuelle reparasjoner eller utskiftinger av anleggets deler må kun utføres av kvalifisert teknisk personell.
- 
 Kutt strømtilførselen til anlegget før ethvert inngrep!

4.1 Utfør følgende periodiske inngrep på generatoren

- 
 Kontroller regelmessig nivået på kjølevæsken i tanken. Hvis tanken er helt tom og/eller det er luft i pumpen, kan det forårsake funksjonsfeil på pumpen.

- Bruk trykkluft med lavt trykk og pensler med myk bust for rengjøring innvendig.
- Kontroller de elektriske kopleingene og alle kopleingskablene.
- Kontroller elektropumpens tilstand.
- Kontroller tilstanden i slangekopleingene.

Hver 6. måned skal du skifte ut kjølevæsken og skylle slangene og tanken med vann. Skift ut væsken hvis den koker, da den ved koking taper sine beskyttende egenskaper.



Påfylling eller fylling av kjølevæske i tanken skal utføres med generatorens og WU montert og plassert på et horisontalt plan.



Påfylling eller etterfylling av tanken skal utføres med kjølevæske kode 18.91.008. Utstyret må ikke bli brukt uten kjølevæske.



Bruk ikke ledende kjølevæsker.



Bruk trykkluft med lavt trykk og pensler med myk bust for rengjøring innvendig. Kontroller de elektriske koplingene og alle koplingskablene.

4.2 Sorumluluk



Hvis det ordinære vedlikeholdsarbeidet ikke blir utført, blir garantien erklært ugyldig og fabrikanten fritas for alt ansvar. Hvis operatøren ikke følger disse instruksene, frasier fabrikanten seg alt ansvar. Ikke nøl med å ta kontakt med nærmeste tekniske assistansesenter hvis du skulle være i tvil eller det skulle oppstå problemer.

5. ALARM KODER



ALARM















Utløsningen av en alarm eller overstigningen av en kritisk sikkerhetsterskel, fører til en visuell varsling på kontrollpanelet og en umiddelbar blokkering av sveisingen.



ADVARSEL

Overstigningen av en sikkerhetsterskel fører til en visuell varsling på kontrollpanelet, men tillater å fortsette sveisingen.

Nedenfor finnes en liste over anleggets alarmer og sikkerhetsgrenser.

 E43	Mangel på kjølevæske		 E71	Overtemperatur kjølevæske	
 E76	Strømningsnivå for kjølevæske oversteget		 E77	Temperaturnivå kjølevæske	
 E81	Overstrøm (WU-pumpe)		 E82	Kommunikasjonsfeil (WU)	
 E83	Pumpe blokkert				

6. DIAGNOSTIKK OG LØSNINGER

Mangel på gjennomstrømning i kretsen

Årsak

- » Mangel på væske i tanken.
- » Luft i kjølesystemet.

Løsning

- » Etterfyll.
- » Kople forbi til utløpstilkoplingen (blå farve) og luft hydraulikkretsen. La kjølevæskens strømme i noen få sekunder.

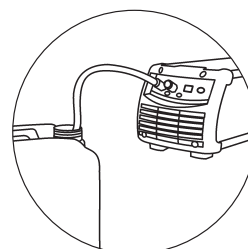

- | | |
|--------------------------------------|--|
| » Kjølekretsen blokkert eller brutt. | » Kontroller tilstanden på tilkoplingene (inne i enheten) på hydraulikkretsen.
» Kontroller tilstanden på brennerens hydraulikkrets.
» Kontroller tilstanden av kjølekretsen i kabelbunten.
» Henvend deg til det nærmeste senter for teknisk assistanse for å reparere anlegget. |
| » Alarm utløst på kjøleenheten. | » Reset alarmen.
» Tilkople en brenner eller forbikople i en operasjonsmodus som krever at kjøleenheten er aktiv.
» Kontroller tilstanden på tilkoplingene (inne i enheten) på hydraulikkretsen.
» Kontroller tilstanden på brennerens hydraulikkrets.
» Henvend deg til det nærmeste senter for teknisk assistanse for å reparere anlegget. |
| » Defekt pumpe. | » Skift ut den skadde komponenten.
» Henvend deg til det nærmeste senter for teknisk assistanse for å reparere anlegget. |





Utilfredsstillende kjølekapasitet

- | Årsak | Løsning |
|-----------------|---|
| » Defekt pumpe. | » Skift ut den skadde komponenten.
» Henvend deg til det nærmeste senter for teknisk assistanse for å reparere anlegget. |
| » Defekt pumpe. | » Skift ut den skadde komponenten.
» Henvend deg til det nærmeste senter for teknisk assistanse for å reparere anlegget. |

7. TEKNISK SPESIFIKASJON

Elektriske egenskaper			U.M.
Strømforsyningsspenning U1	360		Vdc
Maksimal absorbert strøm I1max	0.4		A
Avkjølingseffekt (25°C)	1000		W
Fysiske egenskaper			U.M.
Vernegrad IP	IP23S		
Mål (lxdxh)	660x240x220		mm
Vekt	12.0		Kg
Utvekslertype	H ₂ O - Luft		
Nominal kapasitet (QV)	2.3		l/min
Maks. pumpeutkapasitet (Qvmax)	4.6		l/min
Pumpeutbredelse (Hmax)	35		m
Pumpetype	Roterende		
Maks. turtall	3300		RPM
Tankens kapasitet	3.0		l
Produksjonsnormer	EN IEC 60974-2:2019 EN 60974-10/A1:2015		

8. DATASKILT

 VOESTALPINE BÖHLER WELDING ARC TECHNOLOGY S.R.L. Via Palladio, 19 - ONARA (PADOVA) - ITALY		
WU 2000	N°	
EN 60974-2:2019 IEC 60974-10/A1:2015 Class A		
Energy input		
	U ₁ 350V	I _{1max} 0.35A
	IP 23 S	
Liquid cooling system		
	P _{11/min} 1.0kW	P _{max} 0.35MPa (3.5bar)
		CE UK CA EAC MADE IN ITALY 

9. BESKRIVELSE INFORMASJONSSKILT

1		2	
3		4	
5			
6			
6	7	8	
	9		
10			
10	11	12	
		CE UK CA EAC MADE IN ITALY 	

- 1 Produksjonsmerke
- 2 Navn og adresse til produsenten
- 3 Apparatmodell
- 4 Serienummer
- XXXXXXXXXXXXXX Produksjonsår
- 5 Henvising til konstruksjonsstandarder
- 6 Symbol for strømforsyning
- 7 Nominell forsyningsspenning
- 8 Maksimal nominell strøm
- 9 Beskyttelsesgrad
- 10 Kjølensystemsymbol
- 11 Kjølekraft
- 12 Maksimalt trykk

CE EU-samsvarserklæring
 EAC EAC-samsvarserklæring
 UKCA UKCA-samsvarserklæring

EU-VAATIMUSTENMUKAISUUSVAKUUTUS

Rakentaja
voestalpine Böhler Welding Arc Technology S.r.l.
Via Palladio, 19 - 35019 Onara di Tombolo (PD) - ITALY
Tel. +39 049 9413/111 - Fax +39 049 9413/311 - www.voestalpine.com/welding

vakuuttaa omalla vastuullaan, että seuraava tuote:

WU 2000

71.03.076

on seuraavien EU-direktiivien mukainen:

2014/35/EU LOW VOLTAGE DIRECTIVE

2014/30/EU EMC DIRECTIVE

2011/65/EU RoHS DIRECTIVE

ja että seuraavia yhdenmukaistettuja standardeja on sovellettu:

EN IEC 60974-2:2019

LIQUID COOLING SYSTEMS

EN 60974-10/A1:2015

ELECTROMAGNETIC COMPATIBILITY REQUIREMENTS

Asiakirjat, jotka todistavat direktiivien noudattamisen, pidetään saatavilla tarkastuksia varten edellä mainitulla valmistajalla.

Jokainen korjaus tai muutos ilman voestalpine Böhler Welding Arc Technology S.r.l.:n antamaa lupaa tekee tästä ilmoituksesta pätemättömän.

Onara di Tombolo, 01/05/2025

voestalpine Böhler Welding Arc Technology S.r.l.



Mirco Frasson

Ivo Bonello

Managing Directors

SISÄLLYS

1. VAROITUS.....	127
1.1 Työskentelytila	127
1.2 Käyttäjän ja ulkopuolisten henkilöiden suojaaminen	127
1.3 Suojaus sähköiskulta	127
1.4 Sähkömagneettiset kentät ja häiriöt.....	128
1.5 IP-luokitus.....	128
1.6 Jäähdytysneste	128
2. ASENNUS	129
2.1 Nosto, kuljetus ja purkaus.....	129
2.2 Laitteen sijoitus.....	129
2.3 Kytkenä.....	129
2.4 Käyttöönotto	129
3. LAITTEEN ESITTELY.....	131
3.1 Takapaneeli.....	131
3.2 Etuohjauspaneeli.....	132
4. HUOLTO	132
4.1 Suorita seuraavat määräaikaist tarkastukset virtalähteelle	132
4.2 Rämpundere.....	133
5. HÄLYTYSKOODIT	133
6. VIANMÄÄRITYS JA RATKAISUT.....	133
7. TEKNISET OMINAISUUDET.....	134
8. ARVOKILPI	135
9. KILVEN SISÄLTÖ.....	135
10. KYTKENTÄKAAVIO.....	149
11. LIITTIMET.....	150
12. VARAOSALUETTELO	151

SYMBOLIT



Varoitus



Kiellot



Velvoitteet



Yleisiä viitteitä

1. VAROITUS



Ennen työskentelyä laitteella, varmista että olet lukenut ja ymmärtänyt tämän käyttöohjeen sisällön.

Älä tee muutoksia tai huoltotoimenpiteitä, joita ei ole kuvattu tässä ohjeessa. Valmistajaa ei voida pitää syyllisenä henkilö- tai omaisuusvahinkoihin, jotka aiheutuvat tämän materiaalin huolimattomasta lukemisesta tai virheellisestä soveltamisesta.

Säilytä käyttöohjeet aina laitteen käyttöpaikassa. Noudata käyttöohjeiden lisäksi voimassa olevia paikallisia tapaturmantorjuntaa ja ympäristön suojelua koskevia yleisiä määräyksiä ja sääntöjä.

voestalpine Böhler Welding Arc Technology S.r.l.:n pidättää oikeuden tehdä muutoksia ohjeeseen ilman eri ilmoitusta. Tätä käyttöohjetta ei saa kääntää vieraalle kielelle, muuttaa tai kopioida ilman voestalpine Böhler Welding Arc Technology S.r.l.:n antamaa kirjallista lupaa.

Esitetty tieto on äärimmäisen tärkeää sekä välttämätöntä takuiden soveltamiselle.

Valmistaja ei vastaa vahingoista, mikäli laitteen käyttäjä ei ole noudattanut annettuja ohjeita.



Kaikkien laitteen käyttöönottoon, käyttöön, huoltoon ja korjaukseen osallistuvien henkilöiden tulee:

- omata asianmukainen pätevyys
- lukea nämä käyttöohjeet kokonaan ja noudattaa niitä tarkasti

Käänny ammattitaitoisen henkilön puoleen epäselvissä tapauksissa sekä koneen käyttöön liittyvissä ongelmissa, myös sellaisissa tapauksissa, joihin näissä ohjeissa ei ole viitattu.

1.1 Työskentelytila



Kaikkia laitteita tulee käyttää ainoastaan siihen käyttöön, mihin ne on tarkoitettu, niiden arvokilvessä ja/tai tässä käyttöoppaassa olevien ohjeiden mukaisesti, noudattaen kansallisia ja kansainvälisiä turvallisuusdirektiivejä. Kaikki muu käyttö katsotaan sopimattomaksi ja vaaralliseksi, eikä valmistaja vastaa virheellisestä käytöstä johtuvista vahingoista.



Tämä laite on suunniteltu vain ammattimaiseen käyttöön teollisessa ympäristössä. Valmistaja ei vastaa vahingoista, jotka ovat aiheutuneet siitä, että laitetta on käytetty kotitaloudessa.



Laitetta tulee käyttää tiloissa, joiden lämpötila on -10°C ja +40°C välillä (+14°F... +104°F).

Laitetta tulee kuljettaa ja varastoida tiloissa, joiden lämpötila on -25°C ja +55°C välillä (-13°F... 131°F).

Laitetta ei saa käyttää tiloissa, joissa on pölyä, happeja, kaasuja tai muita syövyttäviä aineita.

Laitetta ei saa käyttää tiloissa, joiden suhteellinen kosteus on yli 50%, 40°C:ssa (104°F).

Laitetta ei saa käyttää tiloissa, joiden suhteellinen kosteus on yli 90%, 20°C:ssa (68°F).

Laitetta tulee käyttää korkeintaan 2000m (6500 jalkaa) merenpinnan yläpuolella.

1.2 Käyttäjän ja ulkopuolisten henkilöiden suojaaminen



Tarkista, että poltin on jäähtynyt ennen huolto- tai työskentelytoimenpiteiden aloittamista.



Tarkista, että jäähdytysyksikkö on sammutettu ennen kuin irrotat jäähdytysnesteen syöttö- ja takaisinvirtausletkut. Ulostuleva kuuma neste voi aiheuttaa vakavia palovammoja tai -haavoja.



Pidä ensiapupakkaus aina lähettyvillä.

Älä aliarvioi palovammojen tai muiden loukkaantumisten mahdollisuutta.



Ennen kuin poistut työpaikalta, varmista työskentelyalueen turvallisuus henkilö- ja esinevahinkojen välttämiseksi.

1.3 Suojaus sähköiskulta



Sähköisku voi johtaa kuolemaan.

- Älä koske hitsausaitteen sisä- tai ulkopuolella olevia jännitteisiä osia laitteen ollessa virtalähteeseen kytkettynä (polttimeet, pihdit, maadoituskaapelit, elektrodit, rullat ja kelat on kytketty sähköisesti hitsauspiiriin).
- Varmista järjestelmän ja käyttäjän sähköeristys käyttämällä kuivia tasoja ja alustoja, jotka on eristetty riittävästi maa- ja laitteen potentiaalista.

1.4 Sähkömagneettiset kentät ja häiriöt

1.4.1 EMC-luokitus standardin mukaisesti: EN 60974-10/A1:2015.

- Luokan B** Luokan B laite täyttää sähkömagneettisen yhteensopivuuden vaatimukset teollisuus- ja asuinympäristössä, mukaan lukien asuintalot, joissa sähkönjakelu tapahtuu julkisen matalajänniteverkon kautta.
- Luokan C** Luokan C laitetta ei ole tarkoitettu käytettäväksi asuintaloissa, joissa sähkönjakelu tapahtuu julkisen matalajänniteverkon kautta. Luokan A laitteiden sähkömagneettisen yhteensopivuuden saavuttaminen voi olla vaikeaa näissä olosuhteissa johtuvien ja säteilevien häiriöiden takia.

Katso lisätietoja luvusta: ARVOKILPI tai TEKNISET OMINAISUUDET.

1.4.2 Asennus, käyttö ja alueen tarkistus

Tämä laite on valmistettu yhdenmukaistettua standardia noudattaen EN 60974-10/A1:2015 ja on luokiteltu "A LUOKKAAN". Tämä laite on suunniteltu vain ammattimaiseen käyttöön teollisessa ympäristössä. Valmistaja ei vastaa vahingoista, jotka ovat aiheutuneet siitä, että laitetta on käytetty kotitaloudessa.



Laitteen käyttäjän tulee olla alan ammattilainen, joka on vastuussa laitteen asennuksesta ja sen käytöstä valmistajan ohjeita noudattaen. Jos jotain sähkömagneettista häiriötä on havaittavissa niin käyttäjän on ratkaistava ongelma, jos tarpeen yhdessä valmistajan teknisellä avulla.



Kaikissa tapauksissa sähkömagneettisia häiriöitä on vaimennettava niin paljon, etteivät ne enää aiheuta haittaa.



Ennen laitteen asennusta käyttäjän on arvioitava sähkömagneettiset ongelmat, jotka mahdollisesti voivat tulla esiin lähiympäristössä, keskittyen erityisesti henkilöiden terveydentilaan, esimerkiksi henkilöiden, joilla on sydäntahdistin tai kuulokoje.

1.4.3 Suojaus

Ympäristön muiden kaapeleiden ja laitteistojen valikoiva suojaus voi vähentää häiriöongelmia. Koko hitsauslaitteiston suojaus voidaan ottaa huomioon erikoissovellutuksissa.

1.5 IP-luokitus

- IP** **IP23S**
- Kotelo on suojattu läpimitoiltaan 12,5 mm tai suurempien kiintoaineiden läpitukeutumiselta, ja vaaralliset osat on kosketussuojattu sormilta.
 - Kotelointi suojaa roiskevedeltä joka suuntautuu 60° kulmassa pystysuunnasta.
 - Kotelointi suojaa sellaisia vaurioita vastaan, jotka aiheuttaa veden sisäänkäyminen laitteiston liikkuvien osien ollessa liikkeessä.

1.6 Jäähdytysneste

1.6.1 Henkilöturvallisuus



Tuote on myrkyllistä nieltynä. Voi ärsyttää silmiä, limakalvoja ja ihoa.



Kädet suojattava käyttämällä kumisia suojakäsineitä.



Silmät suojattava roiskeilta käyttämällä suojalaseja.



Ihokosketus estettävä suojavaatetusta käyttämällä.

1.6.2 Loppukäsittely



Älä hävitä sähkölaitetta tavallisten jätteiden seassa! Sähkö- ja elektroniikkalaiteromua koskevan eurooppalaisen direktiivin 2012/19/EU ja sen täytäntöönpanevien kansallisten lakien mukaisesti sähkölaitteet tulee käyttökänsä päätyttyä erilliskerätä ja toimittaa kierrätys- ja loppukäsittelykeskukseen. Laitteen omistajan tulee tiedustella valtuutetuista jätteenkeräyskeskuksista paikallisviranomaisilta. Eurooppalaisen direktiivin soveltaminen vaikuttaa myönteisesti ympäristöön ja ihmisten terveyteen.



Kun tuotetta on käytetty sen normaalitarkoitukseen, tulee päästöt tai jätteet käsitellä käyttöön soveltuvassa puhdistuslaitteessa, tai mikäli mahdollista, kierrättää tuote. Ei saa päästää vesistöön, maaperään tai viemäriin. Laimennettua nestettä ei saa päästää viemäristöön muuten kuin paikallisen vesilaitoksen säännösten ja lupaehtojen mukaisesti.

2. ASENNUS

2.1 Nosto, kuljetus ja purkaus

- Laitteessa ei ole erityisiä nosto-osia.



Älä koskaan aliarvioi laitteen painoa, katso kohta Tekniset ominaisuudet.

Älä koskaan kuljeta laitetta tai jätä sitä roikkumaan niin, että sen alla on ihmisiä tai esineitä.

Älä anna laitteen kaatua äläkä pudota voimalla.

2.2 Laitteen sijoitus



Noudata seuraavia sääntöjä:

- Varmista helppo pääsy laitteen säätöihin ja liitäntöihin.
- Älä sijoita laitetta ahtaaseen paikkaan.
- Älä aseta laitetta vaakasuoralle tasolle tai tasolle, jonka kaltevuus on yli 10°.
- Kytke laitteisto kuivaan ja puhtaaseen tilaan, jossa on sopiva ilmastointi.
- Suojaa kone sateelta ja auringolta.
- » Katso kappale "Kaasupullojen turvallinen käyttö".

2.3 Kytkentä



Irrota laite sähköverkosta ennen huoltotoimenpiteitä.

2.4 Käyttöönotto

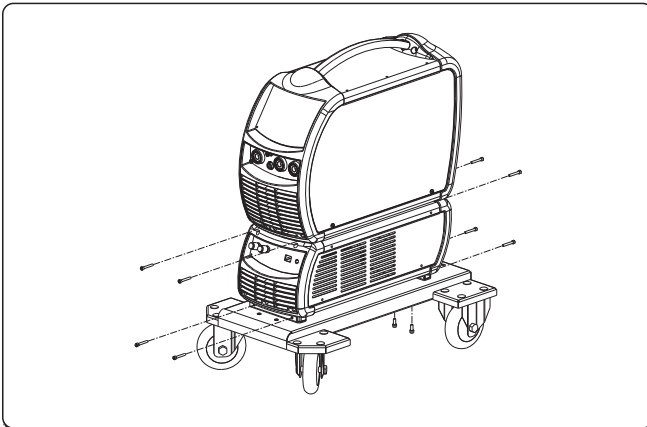

- ▶ Aseta WU GT:n päälle ja kiinnitä 4:n ruuvin avulla.
- ▶ Aseta generaattori jäähdytysyksikön päälle ja kiinnitä ruuveilla.

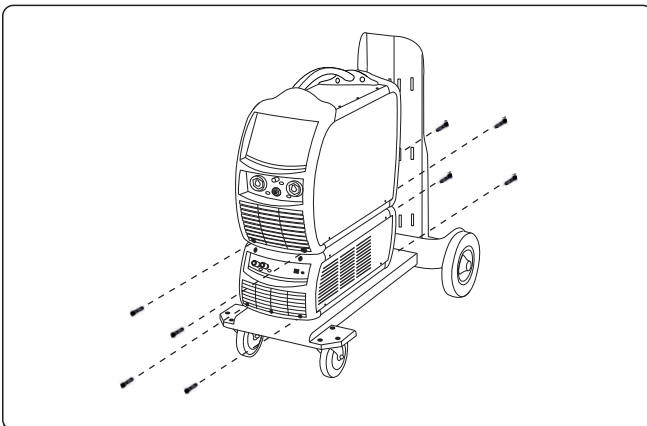

- ▶ Aseta WU GT:n päälle ja kiinnitä 4:n ruuvin avulla.
- ▶ Aseta generaattori jäähdytysyksikön päälle ja kiinnitä ruuveilla.

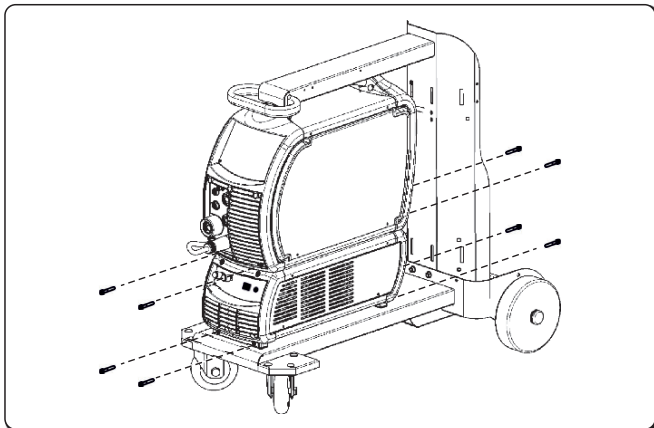

- ▶ Aseta WU GT:n päälle ja kiinnitä 4:n ruuvin avulla.
- ▶ Aseta generaattori jäähdytysyksikön päälle ja kiinnitä ruuveilla.

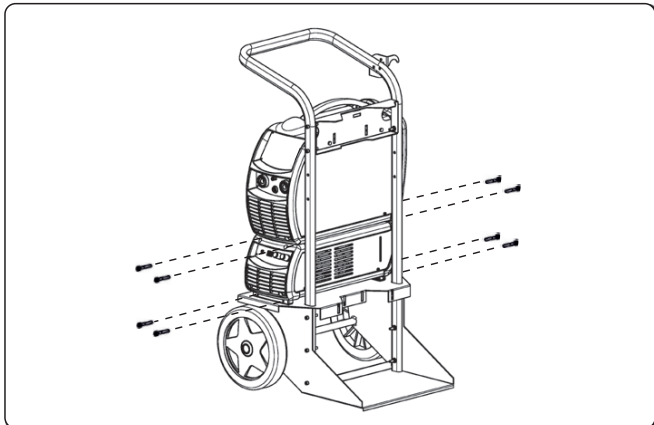

- ▶ Aseta WU GT:n päälle ja kiinnitä 4:n ruuvin avulla.
- ▶ Aseta generaattori jäähdytysyksikön päälle ja kiinnitä ruuveilla.



Ennen yksikön käynnistämistä suorita seuraavat toimenpiteet:

- ▶ Poista säiliön korkki.
- ▶ Irrota sisääntulokanavan hermeettinen korkki sen reunassa olevalla työkalulla.
- ▶ Lisää säiliöön tarvittaessa nestettä.
- ▶ Säilytä hermeettinen korkki mahdollisia tulevaisuudessa tapahtuvia kuljetuksia varten.



Jotta et vahingoittaisi jäähdytysyksikköä asenna aina ohitusputki, kun poltinta ei ole kytketty jäähdytysnesteen sisäänmeno/ulostuloliittimiin.





Säiliön täyttöön käytetään jäähdytysnestettä, tilausnumero 18.91.008.

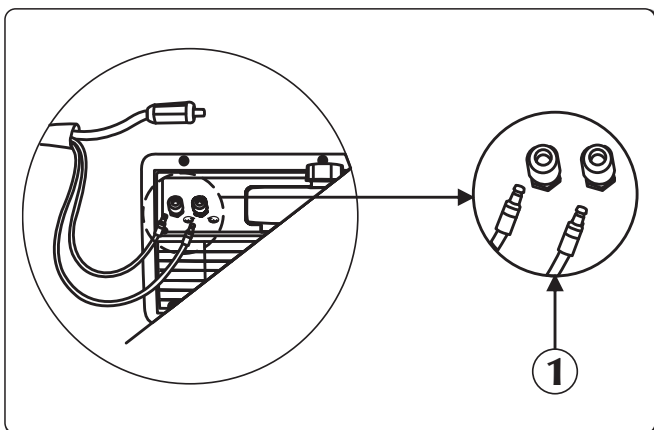

2.4.1 Takapaneelin liitännät

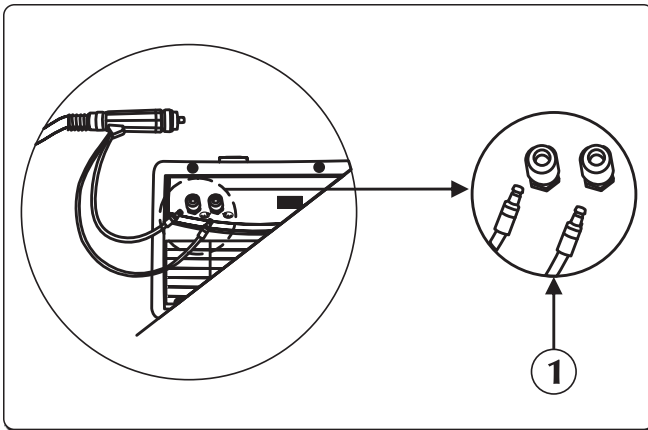

① Jäähdytysnesteen tulo/lähtö

- ▶ Kiinnitä johdinsarjan jäähdytysaineen syöttöletku (sininen) liitännään/kytkentään (sininen - symboli .
- ▶ Kiinnitä johdinsarjan jäähdytysaineen takaisinvirtausletku (punainen) liitännään/kytkentään (punainen - symboli .

2.4.2 Etupaneelin liitäntä

① Jäähdytysnesteen tulo/lähtö

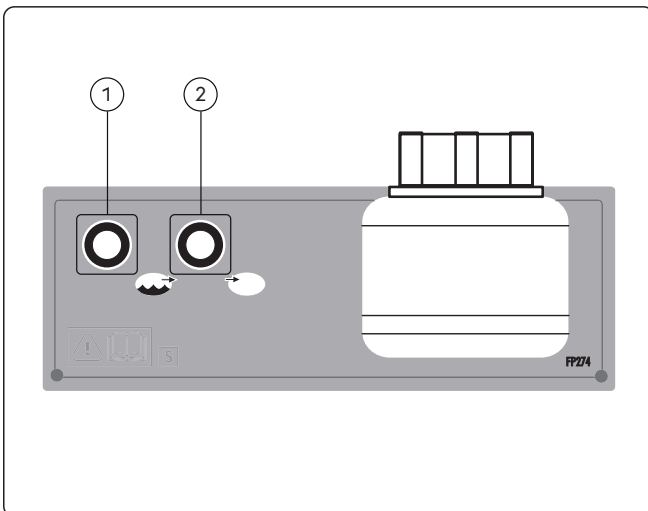
- ▶ Kiinnitä polttimen jäähdytysaineen syöttöletku (sininen) liitäntään/kytkentään (sininen - symboli )
- ▶ Kiinnitä polttimen jäähdytysaineen takaisinvirtausletku (punainen) liitäntään/kytkentään (punainen - symboli )

3. LAITTEEN ESITTELY
3.1 Takapaneeli

① Jäähdytysnesteen ulostuloliitin



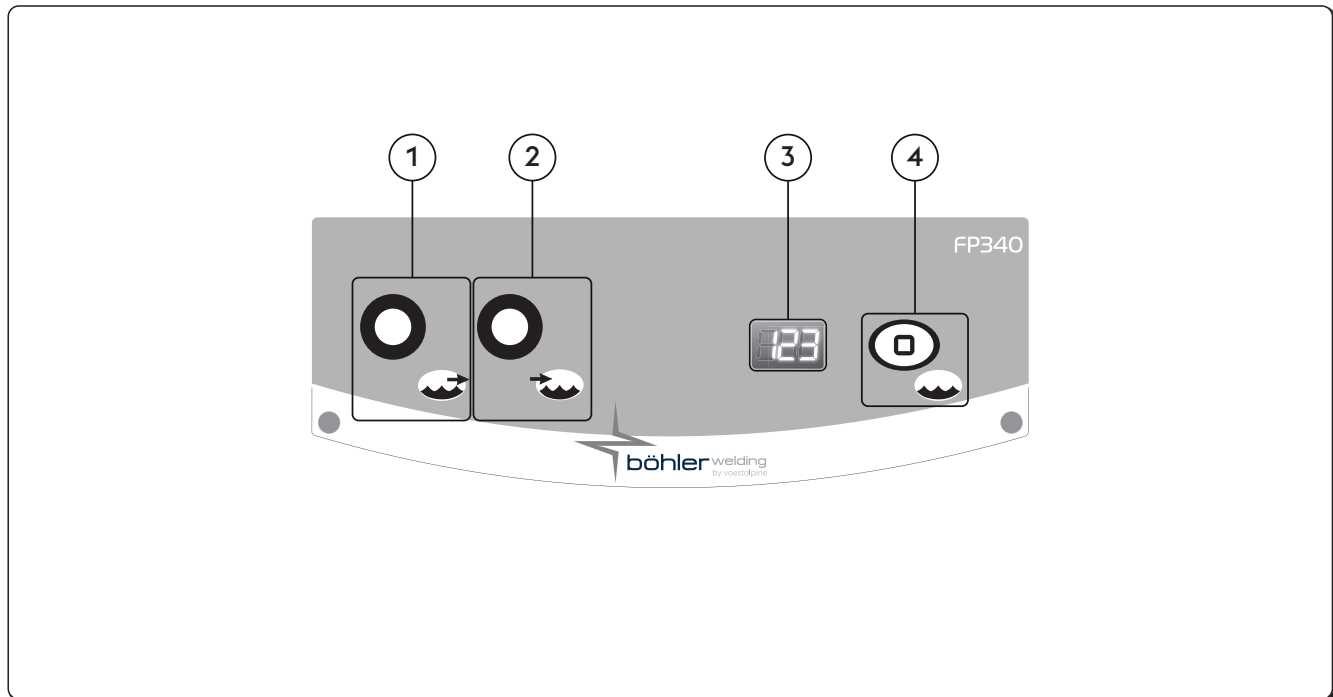

Viileän nesteen syöttö polttimen jäähdytysjärjestelmään.

② Jäähdytysnesteen sisääntuloliitin



Polttimen lämmittämän nesteen syöttö WU:n sisäiseen jäähdytysjärjestelmään.

3.2 Etuohjauspaneeli



- 1  **Jäähdytysnesteen ulostuloliitin**
Viileän nesteen syöttö polttimen jäähdytysjärjestelmään.
- 2  **Jäähdytysnesteen sisääntuloliitin**
Polttimen lämmittämän nesteen syöttö WU:n sisäiseen jäähdytysjärjestelmään.
- 3  **7-segmenttinäyttö**
Mahdollistaa WU:n yleisten parametrien näytön WU:n käynnistyksen ja käytön aikana sekä jäähdytysnesteen sisäisen lämpötilan näytön.
-- Jäähdytysyksikkö pois käytöstä.
- 4  **Jäähdytysyksikön testi**

4. HUOLTO

-  Laitteessa tulee suorittaa normaalihuolto valmis- tajan antamien ohjeiden mukaisesti. Kun laite on toimiva, kaikki laitteen suojapellit ja luukut on suljettava. Laitteeseen ei saa tehdä minkäänlaisia muutoksia. Estä metallipölyä kasaantumasta lähelle tuuletusaukkoja tai niiden päälle.
-  Huoltotoimia voi tehdä vain niihin pätevöitynyt henkilö. Takuun voimassaolo lakkaa, mikäli valtuuttamattomat henkilöt ovat suorittaneet laitteen korjaus- tai osien vaihtotoimenpiteitä. Ainoastaan ammattitaitoiset teknikot saavat suorittaa laitteen mahdolliset korjaus- tai osien vaihtotoimenpiteet.
-  Irrota laite sähköverkosta ennen huoltotoimenpiteitä.

4.1 Suorita seuraavat määräaikaiset tarkastukset virtalähteelle

-  Jäähdytysnesteen taso säiliössä on tarkistettava säännöllisesti. Säiliön täydellinen tyhjentyminen ja/tai pumpussa oleva ilma voivat estää pumpun käynnistyksen.
- Puhdista virtalähde sisältä matalapaineisella paineilmasuihkulla ja pehmeällä harjalla.
 - Tarkista sähköiset kytkennät ja kytkentäkaapelit.
 - Tarkista sähköpumpun kunto.
 - Tarkista putkien liitännät.

Kuuden kuukauden välein on vaihdettava jäähdytysneste sekä huuhdeltava putket ja säiliö vedellä. Jäähdytysneste tulee vaihtaa, jos se on kiehuva, sillä silloin se menettää metalliset suojaominaisuudet.



Jäähdytysnestesäiliön täyttö suoritetaan generaattorin ja WU:n ollessa asennettuina ja vaakatasoiselle alustalle asetettuina.



Säiliön täyttöön käytetään jäähdytysnestettä, tilausnumero 18.91.008. Laitteistoa ei saa käyttää ilman jäähdytysnestettä.



Älä käytä johtavia jäähdytysnesteitä.



Puhdista virtalähde sisältä matalapaineisella paineilmasuihkulla ja pehmeällä harjalla. Tarkista sähköiset kytkennät ja kytkentäkaapelit.

4.2 Räspundere



Ellei huoltoa suoriteta, kaikkien takuiden voimassaolo lakkaa eikä valmistaja vastaa aiheutuneista vahingoista. Valmistaja ei vastaa vahingoista, jotka ovat aiheutuneet siitä, ettei ylläolevia ohjeita ole noudatettu. Jos sinulla on epäselvyyksiä tai ongelmia, älä epäröi ottaa yhteyttä lähimpään huoltokeskukseen.

5. HÄLYTYSKOODIT



HÄLYTYS





Hälytyksen laukeamisesta tai kriittisen turvallisuusrajan ylityksestä ilmoitetaan ohjauspaneelin merkkivalolla. Se aiheuttaa hitsaustoimenpiteiden välittömän eston.



HUOMIO

Turvallisuusrajan ylityksestä ilmoitetaan ohjauspaneelin merkkivalolla. Se ei estä hitsaustoimenpiteiden jatkamista.

Seuraavassa luetellaan kaikki järjestelmää koskevat hälytykset ja turvallisuusrajat.

 E43	Jäähdytysneste puuttuu		 E71	Jäähdytysnesteen ylikuumentuminen	
 E76	Jäähdytysnesteen virtaustaso ylittynyt		 E77	Jäähdytysnesteen lämpötilataso	
 E81	Ylivirta (WU-pumppu)		 E82	Yhteysvirhe (WU)	
 E83	Pumppu pysähtynyt				

6. VIANMÄÄRITYS JA RATKAISUT

Neste puuttuu järjestelmästä

Syy

- » Säiliössä ei ole nestettä.
- » Ilmaa jäähdytyspiirissä.

Toimenpide

- » Suorita täydennys.
- » Kytke ohitus ulosmenevään liitäntään (sininen) ja ilmaa hydraulipiiri antamalla jäähdytysnesteen virtata ulos muutaman sekunnin ajan.

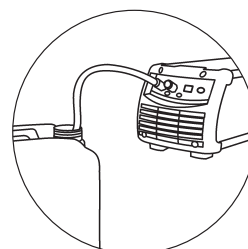

» Jäähdytyspiiri tukossa tai rikkoutunut.

- » Tarkasta hydraulipiirin liitäntöjen kunto (yksikön sisällä).
- » Tarkasta polttimen hydraulipiirin kunto.
- » Tarkasta jäähdytyspiirin kunto kaapelipussissa.
- » Käännä lähimmän huoltokeskuksen puoleen laitteen korjaamista varten.

» Hälytys jäähdytysyksiköstä annettu.

- » Kuittaa hälytys.
- » Käytä poltinta tai ohitusta toimintatiloissa, jotka vaativat jäähdytysyksikön olevan käynnissä.
- » Tarkasta hydraulipiirin liitäntöjen kunto (yksikön sisällä).
- » Tarkasta polttimen hydraulipiirin kunto.
- » Käännä lähimmän huoltokeskuksen puoleen laitteen korjaamista varten.

» Viallinen pumppu.

- » Vaihda viallinen osa.
- » Käännä lähimmän huoltokeskuksen puoleen laitteen korjaamista varten.

Riittämätön jäähdytyskapasiteetti

Syy

» Viallinen tuuletin.

Toimenpide

- » Vaihda viallinen osa.
- » Käännä lähimmän huoltokeskuksen puoleen laitteen korjaamista varten.







» Viallinen pumppu.

- » Vaihda viallinen osa.
- » Käännä lähimmän huoltokeskuksen puoleen laitteen korjaamista varten.





7. TEKNISET OMINAISUUDET

Sähköiset ominaisuudet		U.M.
Syöttöjännite U1	360	Vdc
Maksimi ottovirta I1max	0.4	A
Jäähdytysteho (25°C)	1000	W
Fyysiset ominaisuudet		U.M.
IP-luokitus	IP23S	
Mitat (lxdxh)	660x240x220	mm
Paino	12.0	Kg
Jäähdytintyyppi	H ₂ O - Ilma	
Nimellisteho (QV)	2.3	l/min
Pumpun suurin teho (Qvmax)	4.6	l/min
Pumpun nostokorkeus (Hmax)	35	m
Pumpun tyyppi	Pyörivä	
Maksimi kierrosluku	3300	RPM
Säiliön tilavuus	3.0	l
Standardit	EN IEC 60974-2:2019 EN 60974-10/A1:2015	

8. ARVOKILPI

 VOESTALPINE BÖHLER WELDING ARC TECHNOLOGY S.R.L. Via Palladio, 19 - ONARA (PADOVA) - ITALY		
WU 2000		N°
EN IEC	60974-2:2019 60974-10/A1:2015 Class A	
Energy input		
	U ₁ 350V	I _{1max} 0.35A
	IP 23 S	
Liquid cooling system		
	P _{11/min} 1.0kW	P _{max} 0.35MPa (3.5bar)
  		
MADE IN ITALY 		

9. KILVEN SISÄLTÖ

1		2	
3		4	
5			
6			
6	7	8	
	9		
10			
10	11	12	
  			
MADE IN ITALY 			

- 1 Kaupallinen merkki
- 2 Valmistajan nimi ja osoite
- 3 Laitteen malli
- 4 Sarjanro
- XXXXXXXXXXXXXX Valmistusvuosi
- 5 Viittaus rakennestandardeihin
- 6 Virtalähteen symboli
- 7 Nimellisliitäntäjännite
- 8 Suurin nimellisliitäntävirta
- 9 Suojausluokka
- 10 Jäähdytysjärjestelmän symboli
- 11 Jäähdytysteho
- 12 Maksimipaine

CE EU-vaatimustenmukaisuusvakuutus
 EAC EAC-vaatimustenmukaisuusvakuutus
 UKCA UKCA-vaatimustenmukaisuusvakuutus

ΔΗΛΩΣΗ ΣΥΜΜΟΡΦΩΣΗΣ ΕΥ

Ο οικοδόμος
voestalpine Böhler Welding Arc Technology S.r.l.
Via Palladio, 19 - 35019 Onara di Tombolo (PD) - ITALY
Tel. +39 049 9413/111 - Fax +39 049 9413/311 - www.voestalpine.com/welding

δηλώνει με αποκλειστική ευθύνη ότι το ακόλουθο προϊόν:

WU 2000

71.03.076

είναι κατασκευασμένη σε συμμόρφωση με τις Ευρωπαϊκές Οδηγίες:

2014/35/EU LOW VOLTAGE DIRECTIVE

2014/30/EU EMC DIRECTIVE

2011/65/EU RoHS DIRECTIVE

και ότι έχουν εφαρμοστεί τα ακόλουθα εναρμονισμένα πρότυπα:

EN IEC 60974-2:2019

LIQUID COOLING SYSTEMS

EN 60974-10/A1:2015

ELECTROMAGNETIC COMPATIBILITY REQUIREMENTS

Η τεκμηρίωση που πιστοποιεί τη συμμόρφωση με τις οδηγίες θα παραμείνει διαθέσιμη για επιθεωρήσεις στον προαναφερόμενο κατασκευαστή.

Τυχόν επεμβάσεις ή τροποποιήσεις που θα γίνουν χωρίς την εξουσιοδότηση της **voestalpine Böhler Welding Arc Technology S.r.l.**, θα προκαλέσουν την παύση ισχύος της παραπάνω δήλωσης.

Onara di Tombolo, 01/05/2025

voestalpine Böhler Welding Arc Technology S.r.l.

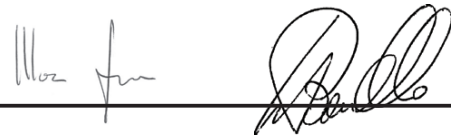

Mirco Frasson Ivo Bonello

Managing Directors

ΠΕΡΙΕΧΟΜΕΝΑ

1. ΠΡΟΕΙΔΟΠΟΙΗΣΕΙΣ	139
1.1 Περιβάλλον χρήσης.....	139
1.2 Ατομική προστασία και ασφάλεια τρίτων	139
1.3 Προστασία από ηλεκτροπληξία.....	140
1.4 Ηλεκτρομαγνητικά πεδία και παρεμβολές.....	140
1.5 Βαθμός προστασίας IP	140
1.6 Υγρό ψύξης.....	140
2. ΕΓΚΑΤΑΣΤΑΣΗ.....	141
2.1 Τρόπος ανύψωσης, μεταφοράς και εκφόρτωσης.....	141
2.2 Τοποθέτηση της διάταξης.....	141
2.3 Σύνδεση	141
2.4 θέση σε λειτουργία	141
3. ΠΑΡΟΥΣΙΑΣΗ ΤΗΣ ΔΙΑΤΑΞΗΣ	143
3.1 Πίσω πάνελ	143
3.2 Μπροστινός πίνακας ελέγχου	144
4. ΣΥΝΤΗΡΗΣΗ	144
4.1 Περιοδικοί έλεγχοι	144
4.2 Ευθύνη.....	145
5. ΚΩΔΙΚΟΙ ΣΥΝΑΓΕΡΜΩΝ (ΑΛΑΡΜ)	145
6. ΔΙΑΓΝΩΣΗ ΠΡΟΒΛΗΜΑΤΩΝ ΚΑΙ ΛΥΣΕΙΣ	145
7. ΤΕΧΝΙΚΑ ΧΑΡΑΚΤΗΡΙΣΤΙΚΑ	146
8. ΠΙΝΑΚΙΔΑ ΧΑΡΑΚΤΗΡΙΣΤΙΚΩΝ.....	147
9. ΣΗΜΑΣΙΑ ΠΙΝΑΚΙΔΑΣ ΧΑΡ ΑΚΤΗΡΙΟΤΙΚΩΝ.....	147
10. ΔΙΑΓΡΑΜΜΑ.....	149
11. ΣΥΝΔΕΤΗΡΕΣ	150
12. ΚΑΤΑΛΟΓΟΣ	151

ΣΥΜΒΟΛΑ



Προειδοποιήσεις



Απαγορεύσεις



Υποχρεώσεις



Γενικές ενδείξεις

1. ΠΡΟΕΙΔΟΠΟΙΗΣΕΙΣ



Πριν προβείτε σε οποιαδήποτε ενέργεια, πρέπει να διαβάσετε και να είστε βέβαιοι ότι κατανοήσατε το παρόν εγχειρίδιο. Μην κάνετε μετατροπές και ενέργειες συντήρησης που δεν περιγράφονται στο παρόν. Ο κατασκευαστής δε φέρει καμία ευθύνη για τυχόν βλάβες, σε πρόσωπα ή πράγματα, που οφείλονται σε πλημμελή ανάγνωση και/ή μη εφαρμογή των οδηγιών του παρόντος εγχειριδίου.

Διατηρείτε πάντα τις οδηγίες χρήσης στον τόπο χρήσης της συσκευής. Εκτός από τις οδηγίες χρήσης, τηρείτε τους γενικούς κανόνες και τους ισχύοντες τοπικούς κανονισμούς για την πρόληψη των ατυχημάτων και την προστασία του περιβάλλοντος.

voestalpine Böhler Welding Arc Technology S.r.l. διατηρεί το δικαίωμα να επιφέρει αλλαγές, ανά πάσα στιγμή και χωρίς καμία προειδοποίηση. Με την επιφύλαξη όλων των δικαιωμάτων.

Απαγορεύεται η μερική ή ολική αναπαραγωγή, η προσαρμογή και η μετάφραση των εγγράφων, με οποιοδήποτε μέσο (συμπεριλαμβανομένων των φωτοτυπιών, φιλμ και μικροφίλμ), χωρίς την έγγραφη εξουσιοδότηση της **voestalpine Böhler Welding Arc Technology S.r.l.**

Τα προαναφερθέντα είναι ζωτικής σημασίας και, κατά συνέπεια, απαραίτητα για την ισχύ των εγγυήσεων.

Ο κατασκευαστής δεν φέρει καμία ευθύνη, σε περίπτωση που ο χειριστής δε συμμορφωθεί με τις οδηγίες.

Όλοι οι υπεύθυνοι για τη θέση σε λειτουργία, τη χρήση, τη συντήρηση και την επισκευή της συσκευής πρέπει:

- να διαθέτουν κατάλληλη εξειδίκευση
- να έχουν διαβάσει πλήρως και να τηρούν σχολαστικά τις παρούσες οδηγίες χρήσης

Για κάθε αμφιβολία ή πρόβλημα σχετικά με τη χρήση της διάταξης, έστω κι αν δεν περιγράφεται εδώ, συμβουλευτείτε κάποιον εξειδικευμένο τεχνικό.



1.1 Περιβάλλον χρήσης



Κάθε διάταξη πρέπει να χρησιμοποιείται αποκλειστικά και μόνο για τις λειτουργίες που σχεδιάστηκε, με τους τρόπους και το εύρος τιμών που αναγράφονται στην πινακίδα χαρακτηριστικών και/ή στο παρόν εγχειρίδιο, και σύμφωνα με τους εθνικούς και διεθνείς κανονισμούς ασφαλείας. Οποιαδήποτε άλλη χρήση, που διαφέρει από αυτές που δηλώνει ρητά ο Κατασκευαστής, θεωρείται απολύτως ανάρμοστη και επικίνδυνη, και, στην περίπτωση αυτή, ο Κατασκευαστής δε φέρει καμία ευθύνη.



Η συσκευή πρέπει να προορίζεται μόνο για επαγγελματική χρήση, σε βιομηχανικό περιβάλλον. Ο κατασκευαστής δε φέρει καμία ευθύνη για βλάβες που ενδεχομένως προκληθούν εξαιτίας της χρήσης της διάταξης μέσα σε κατοικίες.



Η διάταξη πρέπει να χρησιμοποιείται σε χώρους με θερμοκρασία μεταξύ -10°C και $+40^{\circ}\text{C}$ ($+14^{\circ}\text{F}$ και $+104^{\circ}\text{F}$).

Η διάταξη πρέπει να μεταφέρεται και να αποθηκεύεται σε χώρους με θερμοκρασία μεταξύ -25°C και $+55^{\circ}\text{C}$ (-13°F και 131°F).

Η διάταξη πρέπει να χρησιμοποιείται σε περιβάλλον χωρίς σκόνη, οξέα, αέρια ή άλλες διαβρωτικές ουσίες.

Η διάταξη πρέπει να χρησιμοποιείται σε περιβάλλον με σχετική υγρασία μικρότερη του 50%, στους 40°C (104°F).

Η διάταξη πρέπει να χρησιμοποιείται σε περιβάλλον με σχετική υγρασία μικρότερη του 90%, στους 20°C (68°F).

Το μέγιστο επιτρεπόμενο υψόμετρο για τη χρήση της διάταξης είναι 2000 μ. (6500 πόδια).

1.2 Ατομική προστασία και ασφάλεια τρίτων



Πριν κάνετε κάποια ενέργεια πάνω στην τιμπίδα ή προβείτε στη συντήρησή της, βεβαιωθείτε ότι έχει κρυώσει.



Πριν αποσυνδέσετε τους σωλήνες προσαγωγής και επιστροφής του ψυκτικού υγρού, βεβαιωθείτε ότι η μονάδα ψύξης είναι σβηστή. Το θερμό υγρό που βγαίνει μπορεί να προκαλέσει σοβαρά εγκαύματα.



Προμηθευτείτε τα απαραίτητα μέσα πρώτων βοηθειών.

Μην παραμελείτε τυχόν εγκαύματα ή τραυματισμούς.



Πριν εγκαταλείψετε τη θέση εργασίας, πάρτε τα απαραίτητα μέτρα ασφαλείας, για να αποφευχθούν ακούσιες βλάβες και ατυχήματα.

1.3 Προστασία από ηλεκτροπληξία



Η ηλεκτροπληξία μπορεί να προκαλέσει θάνατο.

- Αποφύγετε την επαφή με τα σημεία που βρίσκονται συνήθως υπό τάση, στο εσωτερικό ή στο εξωτερικό της διάταξης συγκόλλησης, όταν η διάταξη έχει ρεύμα (οι τσιμπίδες, τα σώματα γείωσης, τα καλώδια γείωσης, τα ηλεκτρόδια, τα καλώδια, τα ράουλα και τα καρούλια συνδέονται με το ηλεκτρικό κύκλωμα συγκόλλησης).
- Εξασφαλίστε την ηλεκτρική μόνωση της εγκατάστασης και του χειριστή, χρησιμοποιώντας στεγνές επιφάνειες και βάσεις, με επαρκή μόνωση από το δυναμικό του εδάφους και της γείωσης.

1.4 Ηλεκτρομαγνητικά πεδία και παρεμβολές

1.4.1 Ταξινόμηση ΗΜΣ σύμφωνα με το πρότυπο: EN 60974-10/A1:2015.



Η συσκευή κατηγορίας Β είναι κατασκευασμένη σε συμμόρφωση με τις απαιτήσεις συμβατότητας σε βιομηχανικούς χώρους ή κατοικίες, συμπεριλαμβανομένων των κατοικημένων περιοχών όπου η ηλεκτρική ενέργεια παρέχεται από κάποιο δημόσιο σύστημα χαμηλής τάσης.



Η συσκευή κατηγορίας Α δεν προορίζεται για χρήση σε κατοικημένες περιοχές όπου η ηλεκτρική ενέργεια παρέχεται από κάποιο δημόσιο σύστημα χαμηλής τάσης. Θα ήταν δυναμικά δύσκολο να εξασφαλιστεί η ηλεκτρομαγνητική συμβατότητα των συσκευών κατηγορίας Α σε αυτές τις περιοχές, εξαιτίας των παρεμβολών που εκπέμπονται και προσάγονται.

Δείτε το κεφάλαιο για περισσότερες πληροφορίες: ΠΙΝΑΚΙΔΑ ΧΑΡΑΚΤΗΡΙΣΤΙΚΩΝ ή ΤΕΧΝΙΚΑ ΧΑΡΑΚΤΗΡΙΣΤΙΚΑ.

1.4.2 Εγκατάσταση, χρήση και αξιολόγηση του χώρου

Η συσκευή αυτή κατασκευάζεται σύμφωνα με τις οδηγίες του εναρμονισμένου προτύπου EN 60974-10/A1:2015 και κατατάσσεται στην "ΚΑΤΗΓΟΡΙΑ Α". Η συσκευή πρέπει να προορίζεται μόνο για επαγγελματική χρήση, σε βιομηχανικό περιβάλλον. Ο κατασκευαστής δε φέρει καμία ευθύνη για βλάβες που ενδεχομένως προκληθούν εξαιτίας της χρήσης της διάταξης μέσα σε κατοικίες.



Ο χρήστης πρέπει να έχει εμπειρία στον τομέα αυτό και θεωρείται υπεύθυνος για την εγκατάσταση και τη χρήση της συσκευής, σύμφωνα με τις οδηγίες του κατασκευαστή. Αν παρατηρηθούν ηλεκτρομαγνητικές παρεμβολές, ο χρήστης πρέπει να λύσει το πρόβλημα με την τεχνική υποστήριξη του κατασκευαστή.



Σε όλες τις περιπτώσεις, οι ηλεκτρομαγνητικές παρεμβολές πρέπει να ελαττωθούν έως το βαθμό στον οποίο δεν προκαλούν ενόχληση.



Πριν την εγκατάσταση της συσκευής, ο χρήστης πρέπει να εκτιμήσει τα πιθανά ηλεκτρομαγνητικά προβλήματα που θα μπορούσαν να παρουσιαστούν στη γύρω ζώνη και ιδιαίτερα στην υγεία των παρόντων. Για παράδειγμα: άτομα με βηματοδότη (pace-maker) και ακουστικά βαρηκοΐας.

1.4.3 Θωράκιση

Η επιλεκτική θωράκιση άλλων καλωδίων και συσκευών στη γύρω περιοχή μπορεί να μειώσει τα προβλήματα παρεμβολών.

Σε ειδικές εφαρμογές, θα μπορούσε να ληφθεί υπόψη η θωράκιση όλης της διάταξης συγκόλλησης.

1.5 Βαθμός προστασίας IP



IP23S

- Περιβάλημα που αποτρέπει την τυχαία πρόσβαση σε επικίνδυνα μέρη κάποιου δάχτυλου ή κάποιου ξένου σώματος με διάμετρο ίση ή μεγαλύτερη από 12,5 mm.
- Περιβάλημα προστατευμένο από βροχή που πέφτει με γωνία 60°.
- Περιβάλημα που αποτρέπει τις βλαβερές συνέπειες της εισόδου νερού, όταν τα κινούμενα μέρη της συσκευής είναι ακίνητα.

1.6 Υγρό ψύξης

1.6.1 Ατομική προστασία



Βλαβερό σε περίπτωση κατάποσης.

Μπορεί να προκαλέσει ερεθισμό στα μάτια, στη βλεννογόνο και στο δέρμα.



Αποφύγετε την επαφή φορώντας λαστιχένια γάντια.



Για να αποφύγετε τα πιτσιλίσματα, φοράτε προστατευτικά γυαλιά.



Για να αποφύγετε την επαφή με το δέρμα, φοράτε κατάλληλα ρούχα εργασίας.

1.6.2 Διάθεση



Μην απορρίπτετε την ηλεκτρική συσκευή με τα κοινά απόβλητα!

Σύμφωνα με την Ευρωπαϊκή Οδηγία 2012/19/ΕΕ σχετικά με τα απόβλητα ηλεκτρικού και ηλεκτρονικού εξοπλισμού, και για την εφαρμογή της βάσει της εθνικής νομοθεσίας, ο ηλεκτρικός εξοπλισμός που φτάνει στο τέλος του κύκλου ζωής του, πρέπει να συλλέγεται χωριστά και να παραδίδεται σε κέντρο ανάκτησης και διάθεσης. Ο ιδιοκτήτης της συσκευής οφείλει να αναζητήσει τα εξουσιοδοτημένα κέντρα συλλογής απευθυνόμενος στις τοπικές αρχές. Η εφαρμογή της Ευρωπαϊκής Οδηγίας θα επιτρέψει την καλύτερη προστασία του περιβάλλοντος και της υγείας του ανθρώπου.



Οι διαρροές ή τα υπολείμματα του προϊόντος, αφού αυτό έχει χρησιμοποιηθεί με το συνήθη τρόπο, πρέπει να υποβάλλονται σε κατάλληλη επεξεργασία καθαρισμού ή, αν είναι δυνατό, να γίνεται ανακύκλωση του προϊόντος. Δεν επιτρέπεται να διοχετεύετε τα απόβλητα σε ρυάκια, χαντάκια ή υπονόμους. Δεν πρέπει να διοχετεύετε τα αραιωμένα απόβλητα στους υπονόμους, εκτός αν αυτό επιτρέπεται από την τοπική νομοθεσία.

2. ΕΓΚΑΤΑΣΤΑΣΗ

2.1 Τρόπος ανύψωσης, μεταφοράς και εκφόρτωσης

- Η διάταξη δεν διαθέτει ειδικά εξαρτήματα για την ανύψωση.



Μην υποτιμάτε το βάρος της διάταξης (βλ. τεχνικά χαρακτηριστικά).

Κατά την ανύψωση, κανένα άτομο δεν πρέπει να βρίσκεται κάτω από το φορτίο.

Αποφύγετε την πτώση της διάταξης και μην την αποθέτετε με δύναμη στο δάπεδο.

2.2 Τοποθέτηση της διάταξης



Τηρήστε τους εξής κανόνες:

- Εύκολη πρόσβαση στα όργανα ελέγχου και τις συνδέσεις.
- Μην τοποθετείτε τον εξοπλισμό σε στενούς χώρους.
- Μην τοποθετείτε ποτέ τη διάταξη πάνω σε μια επιφάνεια με κλίση μεγαλύτερη από 10° ως προς το οριζόντιο επίπεδο.
- Τοποθετήστε τη διάταξη σε χώρο στεγνό, καθαρό και με επαρκή εξαερισμό.
- Προστατέψτε τη διάταξη από τη βροχή και τον ήλιο.
 - » βλ. παράγραφο "Προληπτικά μέτρα για τη χρήση φιαλών αερίου".

2.3 Σύνδεση



Διακόπτετε την τροφοδοσία ρεύματος, πριν από κάθε επέμβαση!

2.4 Θέση σε λειτουργία

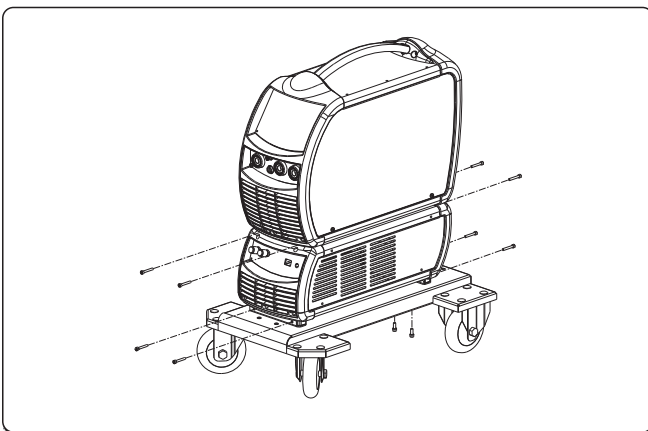

- ▶ Τοποθετήστε το WU πάνω στο GT και στερεώστε το με τις κατάλληλες 4 βίδες.
- ▶ Τοποθετήστε τη γεννήτρια πάνω στη μονάδα ψύξης και στερεώστε την με τις ειδικές βίδες.

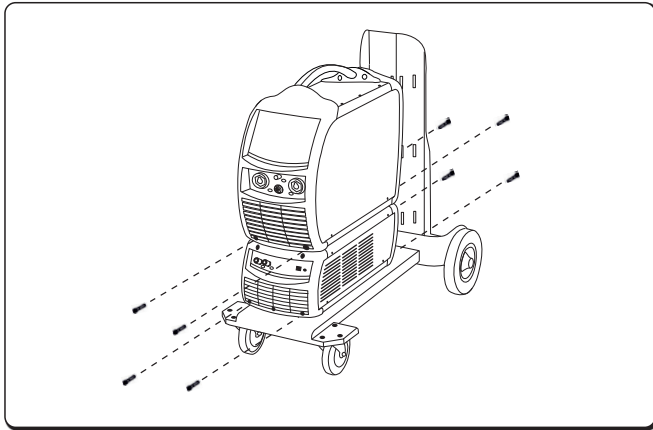

- ▶ Τοποθετήστε το WU πάνω στο GT και στερεώστε το με τις κατάλληλες 4 βίδες.
- ▶ Τοποθετήστε τη γεννήτρια πάνω στη μονάδα ψύξης και στερεώστε την με τις ειδικές βίδες.

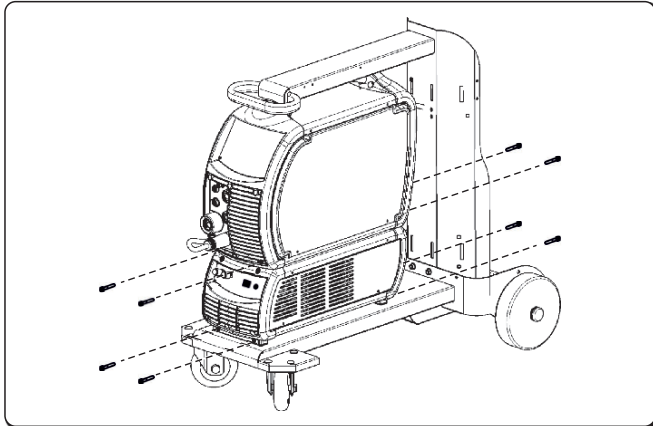

- ▶ Τοποθετήστε το WU πάνω στο GT και στερεώστε το με τις κατάλληλες 4 βίδες.
- ▶ Τοποθετήστε τη γεννήτρια πάνω στη μονάδα ψύξης και στερεώστε την με τις ειδικές βίδες.

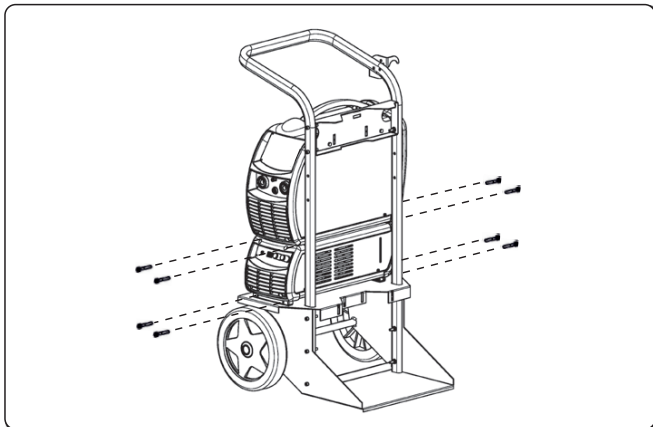

- ▶ Τοποθετήστε το WU πάνω στο GT και στερεώστε το με τις κατάλληλες 4 βίδες.
- ▶ Τοποθετήστε τη γεννήτρια πάνω στη μονάδα ψύξης και στερεώστε την με τις ειδικές βίδες.



Πριν βάλετε τη μονάδα σε λειτουργία, κάντε τις εξής ενέργειες:

- ▶ Αφαιρέστε το πώμα του δοχείου.
- ▶ Βγάλτε το ερμητικό πώμα από το στόμιο πλήρωσης, πιέζοντας με ένα εργαλείο στο χείλος του πώματος.
- ▶ Αν χρειάζεται, προσθέστε υγρό στο δοχείο.
- ▶ Κρατήστε το ερμητικό πώμα για ενδεχόμενες μελλοντικές μεταφορές της μονάδας.



Για να μην προκαλέσετε φθορές στη μονάδα ψύξης, ο σωλήνας by-pass πρέπει να μοντάρεται προτού ακόμη συνδεθεί η τσιμπίδα στους ακροδέκτες εισόδου/εξόδου του ψυκτικού υγρού.



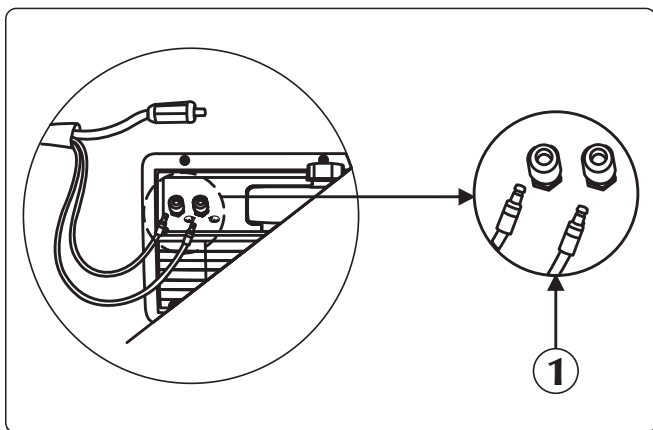

Το ψυκτικό υγρό πλήρωσης ή συμπλήρωσης του δοχείου πρέπει να έχει τον κωδ. 18.91.008.

2.4.1 Σύνδεση οπίσθιου πίνακα





① Είσοδος/έξοδος ψυκτικού υγρού

- ▶ Συνδέστε το σωλήνα προσαγωγής ψυκτικού υγρού, της δέσμης καλωδίων (μπλε χρώματος), στο ειδικό ρακόρ/σύνδεσμο (μπλε χρώματος-σύμβολο ).
- ▶ Συνδέστε το σωλήνα επιστροφής ψυκτικού υγρού, της δέσμης καλωδίων (κόκκινου χρώματος), στο ειδικό ρακόρ/σύνδεσμο (κόκκινου χρώματος-σύμβολο ).

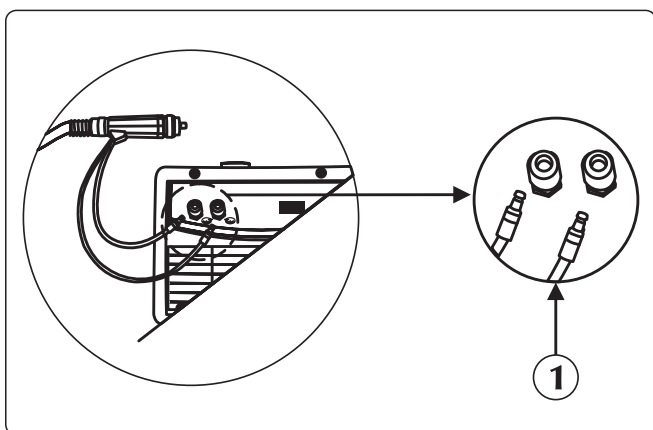
2.4.2 Σύνδεση μπροστινού πίνακα



① Είσοδος/έξοδος ψυκτικού υγρού

- ▶ Συνδέστε το σωλήνα προσαγωγής ψυκτικού υγρού της τσιμπίδας (μπλε χρώματος), στο ειδικό ρακόρ/σύνδεσμο (μπλε χρώματος-σύμβολο ).
- ▶ Συνδέστε το σωλήνα επιστροφής ψυκτικού υγρού της τσιμπίδας (κόκκινου χρώματος), στο ειδικό ρακόρ/σύνδεσμο (κόκκινου χρώματος-σύμβολο ).

3. ΠΑΡΟΥΣΙΑΣΗ ΤΗΣ ΔΙΑΤΑΞΗΣ

3.1 Πίσω πάνελ

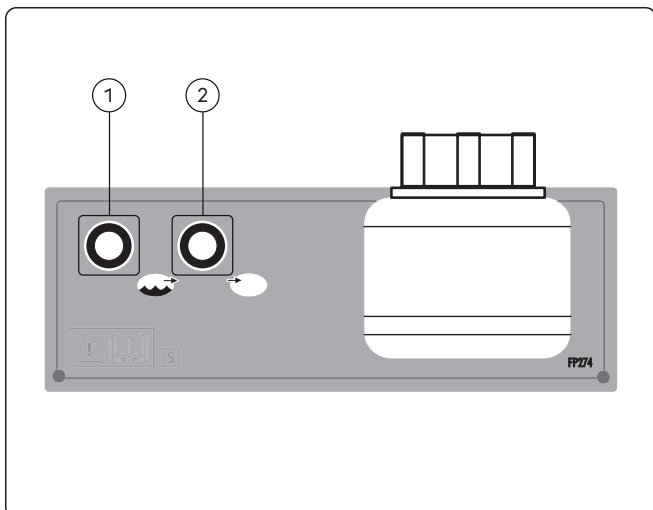

① Ρακόρ/σύνδεσμος εξόδου ψυκτικού υγρού





Επιτρέπει την εισαγωγή του υγρού με χαμηλή θερμοκρασία στο κύκλωμα ψύξης της τσιμπίδας.

② Ρακόρ/σύνδεσμος εισόδου ψυκτικού υγρού

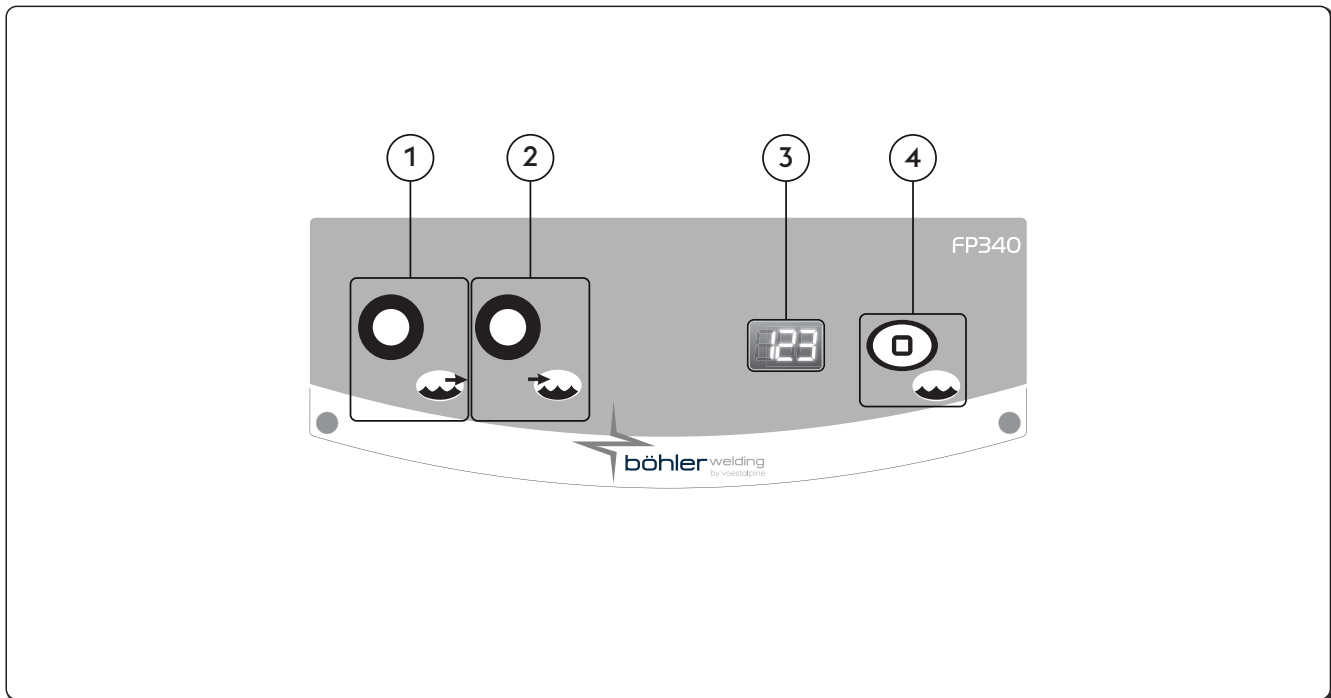

Επιτρέπει την εισαγωγή του υγρού που θερμάνθηκε στην τσιμπίδα, στο εσωτερικό κύκλωμα ψύξης του WU.

3.2 Μπροστινός πίνακας ελέγχου



- 1  Ρακόρ/σύνδεσμος εξόδου ψυκτικού υγρού
Επιτρέπει την εισαγωγή του υγρού με χαμηλή θερμοκρασία στο κύκλωμα ψύξης της τσιμπίδας.
- 2  Ρακόρ/σύνδεσμος εισόδου ψυκτικού υγρού
Επιτρέπει την εισαγωγή του υγρού που θερμάνθηκε στην τσιμπίδα, στο εσωτερικό κύκλωμα ψύξης του WU.
- 3  Οθόνη 7 τμημάτων
Επιτρέπει την εμφάνιση των γενικών στοιχείων της μηχανής WU, κατά την εκκίνηση, την κατάσταση σωστής λειτουργίας και την εσωτερική θερμοκρασία του ψυκτικού υγρού.
-- Μονάδα ψύξης απενεργοποιημένη.
- 4  Τεστ μονάδας ψύξης

4. ΣΥΝΤΗΡΗΣΗ

-  Η διάταξη πρέπει να συντηρείται τακτική, σύμφωνα με τις οδηγίες του κατασκευαστή. Όλες οι θυρίδες πρόσβασης και συντήρησης, καθώς και τα καπάκια, πρέπει να είναι κλειστά και καλά στερεωμένα, όταν η συσκευή βρίσκεται σε λειτουργία. Απαγορεύεται οποιαδήποτε μετατροπή της διάταξης. Μην επιτρέπετε τη συσσώρευση μεταλλικής σκόνης γύρω από τα πτερύγια αερισμού.
-  Η ενδεχόμενη συντήρηση πρέπει να εκτελείται μόνο από εξειδικευμένους τεχνικούς. Η επισκευή ή η αντικατάσταση εξαρτημάτων της διάταξης από μη εξειδικευμένο προσωπικό έχει ως συνέπεια την άμεση ακύρωση της εγγύησης του προϊόντος. Η ενδεχόμενη επισκευή ή αντικατάσταση εξαρτημάτων της διάταξης, πρέπει να γίνεται αποκλειστικά από εξειδικευμένους τεχνικούς.



Διακόπτετε την τροφοδοσία ρεύματος, πριν από κάθε επέμβαση!

4.1 Περιοδικοί έλεγχοι

-  Ελέγχετε περιοδικά τη στάθμη του ψυκτικού υγρού στο δοχείο. Το πλήρες άδειασμα του δοχείου και/ή παρουσία αέρα στην αντλία μπορεί να προκαλέσουν προβλήματα στην ομαλή λειτουργία της.

- Καθαρίστε το εσωτερικό με πεπιεσμένο αέρα σε χαμηλή πίεση και μαλακό πινέλο.
- Ελέγχετε τις ηλεκτρικές συνδέσεις και όλα τα καλώδια σύνδεσης.
- Ελέγξτε την κατάσταση της ηλεκτραντλίας.
- Ελέγξτε την κατάσταση των συνδέσεων των σωλήνων.

Κάθε έξι μήνες, αλλάζετε το ψυκτικό υγρό και ξεβγάζετε τους σωλήνες και το δοχείο με νερό. Αλλάξτε το υγρό σε περίπτωση που βράσει, γιατί χάνει τις μεταλλικές προστατευτικές ιδιότητές του.



Η πλήρωση ή συμπλήρωση του δοχείου με ψυκτικό υγρό πρέπει να γίνεται με τη γεννήτρια και τη μονάδα WU συναρμολογημένες και πάνω σε επίπεδη επιφάνεια.



Το ψυκτικό υγρό πλήρωσης ή συμπλήρωσης του δοχείου πρέπει να έχει τον κωδ. 18.91.008. Η διάταξη δεν πρέπει να χρησιμοποιείτε ποτέ χωρίς ψυκτικό υγρό.



Μη χρησιμοποιείτε αγώγιμα ψυκτικά υγρά.



Καθαρίστε το εσωτερικό με πεπιεσμένο αέρα σε χαμηλή πίεση και μαλακό πινέλο. Ελέγχετε τις ηλεκτρικές συνδέσεις και όλα τα καλώδια σύνδεσης.

4.2 Ευθύνη



Σε περίπτωση που δεν γίνεται η συνιστώμενη συντήρηση, παύει η ισχύς όλων των εγγυήσεων και ο κατασκευαστής απαλλάσσεται από οποιαδήποτε ευθύνη. Ο κατασκευαστής δεν φέρει καμία ευθύνη, σε περίπτωση που ο χειριστής δε συμμορφωθεί με τις οδηγίες. Για κάθε αμφιβολία και/ή πρόβλημα, μη διστάσετε να απευθυνθείτε στο πλησιέστερο κέντρο τεχνικής υποστήριξης.

5. ΚΩΔΙΚΟΪ ΣΥΝΑΓΕΡΜΩΝ (ΑΛΑΡΜ)



ΣΥΝΑΓΕΡΜΟΣ

Η επέμβαση ενός συναγερμού ή η υπέρβαση ενός κρίσιμου ορίου επιτήρησης, προκαλεί μια οπτική σήμανση στον πίνακα χειριστηρίων και την άμεση διακοπή των εργασιών συγκόλλησης.



ΠΡΟΣΟΧΗ

Η υπέρβαση ενός ορίου επιφυλακής ενεργοποιεί μία οπτική σήμανση στον πίνακα χειρισμού, αλλά επιτρέπει τη συνέχιση της διαδικασίας συγκόλλησης.

Στη συνέχεια παρουσιάζονται όλοι οι συναγερμοί και όλα τα όρια επιτήρησης σχετικά με την εγκατάσταση.

 E43	Απουσία ψυκτικού υγρού		 E71	Υπερθέρμανση ψυκτικού υγρού	
 E76	Υπέρβαση ορίου ροής ψυκτικού υγρού		 E77	Υπέρβαση ορίου θερμοκρασίας ψυκτικού υγρού	
 E81	Υπερένταση (αντλία WU)		 E82	Σφάλμα επικοινωνίας (WU)	
 E83	Εμπλοκή αντλίας				

6. ΔΙΑΓΝΩΣΗ ΠΡΟΒΛΗΜΑΤΩΝ ΚΑΙ ΛΥΣΕΙΣ

Απουσία ροής στο κύκλωμα

Αιτία

- » Απουσία υγρού στο δοχείο.
- » Αέρας στο κύκλωμα ψύξης.

Λύση

- » Προσθέστε υγρό.
- » Βάλτε το by-pass στο σύνδεσμο εξόδου (μπλε χρώμα) και εξαερίστε το υδραυλικό κύκλωμα, επιτρέποντας την εκροή του ψυκτικού υγρού για μερικά δευτερόλεπτα.

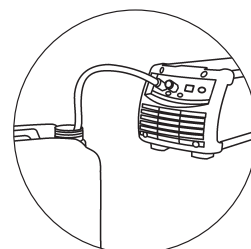

- | | |
|--|---|
| » Απόφραξη ή διακοπή κυκλώματος ψύξης. | » Ελέγξτε την κατάσταση των συνδέσεων (στο εσωτερικό της μονάδας) του υδραυλικού κυκλώματος. |
| | » Ελέγξτε την κατάσταση του υδραυλικού κυκλώματος της τσιμπίδας. |
| | » Ελέγξτε την κατάσταση του υδραυλικού κυκλώματος της δέσμης καλωδίων. |
| | » Απευθυνθείτε στο πλησιέστερο κέντρο τεχνικής υποστήριξης, για την επισκευή της διάταξης. |
| » Παρουσία κατάστασης συναγερμού στη μονάδα ψύξης. | » Εξουδετερώστε τον συναγερμό. |
| | » Συνδέστε μία τσιμπίδα ή το by-pass κατά τους τρόπους λειτουργίας όπου προβλέπεται η ενεργοποίηση της μονάδας ψύξης. |
| | » Ελέγξτε την κατάσταση των συνδέσεων (στο εσωτερικό της μονάδας) του υδραυλικού κυκλώματος. |
| | » Ελέγξτε την κατάσταση του υδραυλικού κυκλώματος της τσιμπίδας. |
| | » Απευθυνθείτε στο πλησιέστερο κέντρο τεχνικής υποστήριξης, για την επισκευή της διάταξης. |
| » Πρόβλημα στην αντλία. | » Αντικαταστήστε το ελαττωματικό εξάρτημα. |
| | » Απευθυνθείτε στο πλησιέστερο κέντρο τεχνικής υποστήριξης, για την επισκευή της διάταξης. |

Ανεπαρκής ψυκτική ικανότητα

Αιτία

- » Πρόβλημα στον ανεμιστήρα.
- » Πρόβλημα στην αντλία.







Λύση

- » Αντικαταστήστε το ελαττωματικό εξάρτημα.
- » Απευθυνθείτε στο πλησιέστερο κέντρο τεχνικής υποστήριξης, για την επισκευή της διάταξης.
- » Αντικαταστήστε το ελαττωματικό εξάρτημα.
- » Απευθυνθείτε στο πλησιέστερο κέντρο τεχνικής υποστήριξης, για την επισκευή της διάταξης.





7. ΤΕΧΝΙΚΑ ΧΑΡΑΚΤΗΡΙΣΤΙΚΑ

Ηλεκτρικά Χαρακτηριστικά		U.M.
Τάση τροφοδοσίας U1	360	Vdc
Μέγιστη απορρόφηση ρεύματος I1max	0.4	A
Δύναμη ψύξης (25°C)	1000	W
Φυσικά χαρακτηριστικά		U.M.
Βαθμός προστασίας IP	IP23S	
Διαστάσεις (ΠxΒxΥ)	660x240x220	mm
Βάρος	12.0	Kg
Τύπος εναλλάκτη	H ₂ O - Αέρας	
Ονομαστική παροχή (QV)	2.3	λίτρα/λεπτό
Μέγιστη παροχή αντλίας (Qnmax)	4.6	λίτρα/λεπτό
Μανομετρικό ύψος αντλίας (Hmax)	35	m
Τύπος αντλίας	Περιστροφική	
Μέγ. αριθμ. στροφών	3300	RPM
Χωρητικότητα δοχείου	3.0	l
Πρότυπα κατασκευής	EN IEC 60974-2:2019 EN 60974-10/A1:2015	

8. ΠΙΝΑΚΊΔΑ ΧΑΡΑΚΤΗΡΙΣΤΙΚΩΝ

 VOESTALPINE BÖHLER WELDING ARC TECHNOLOGY S.R.L. Via Palladio, 19 - ONARA (PADOVA) - ITALY		
WU 2000		N°
EN IEC	60974-2:2019 60974-10/A1:2015 Class A	
Energy input		
	U₁ 350V	I_{1max} 0.35A
	IP 23 S	
Liquid cooling system		
	P_{11/min} 1.0kW	P_{max} 0.35MPa (3.5bar)
  		
MADE IN ITALY 		

9. ΣΗΜΑΣΊΑ ΠΙΝΑΚΊΔΑΣ ΧΑΡΑΚΤΗΡΙΟΤΙΚΩΝ

1		2	
3		4	
5			
6			
6	7	8	
	9		
10			
10	11	12	
  			
MADE IN ITALY 			

- 1 Σήμα κατασκευαστή
- 2 Επωνυμία και διεύθυνση κατασκευαστή
- 3 Μοντέλο συσκευής
- 4 Αριθ. σειράς
X**XX**XXXXXXXXXX Έτος κατασκευής
- 5 Παραπομπή στα πρότυπα κατασκευής
- 6 Σύμβολο τροφοδοσίας
- 7 Ονομαστική τάση τροφοδοσίας
- 8 Μέγιστο ονομαστικό ρεύμα τροφοδοσίας
- 9 Βαθμός προστασίας
- 10 Σύμβολο συστήματος ψύξης
- 11 Δύναμη ψύξης
- 12 Μέγιστη πίεση

CE Δήλωση συμμόρφωσης EE
 EAC Δήλωση συμμόρφωσης EAC
 UKCA Δήλωση συμμόρφωσης UKCA

10. SCHEMA, DIAGRAM, SCHALTPLAN, SCHEMA, ESQUEMA, DIAGRAMA, SCHEMA, KOPPLINGSSCHEMA, OVERSICHT, SKJEMA, KYTKENTÄKAAVIO, ΔΙΑΓΡΑΜΜΑ

WU 2000 (71.03.076)

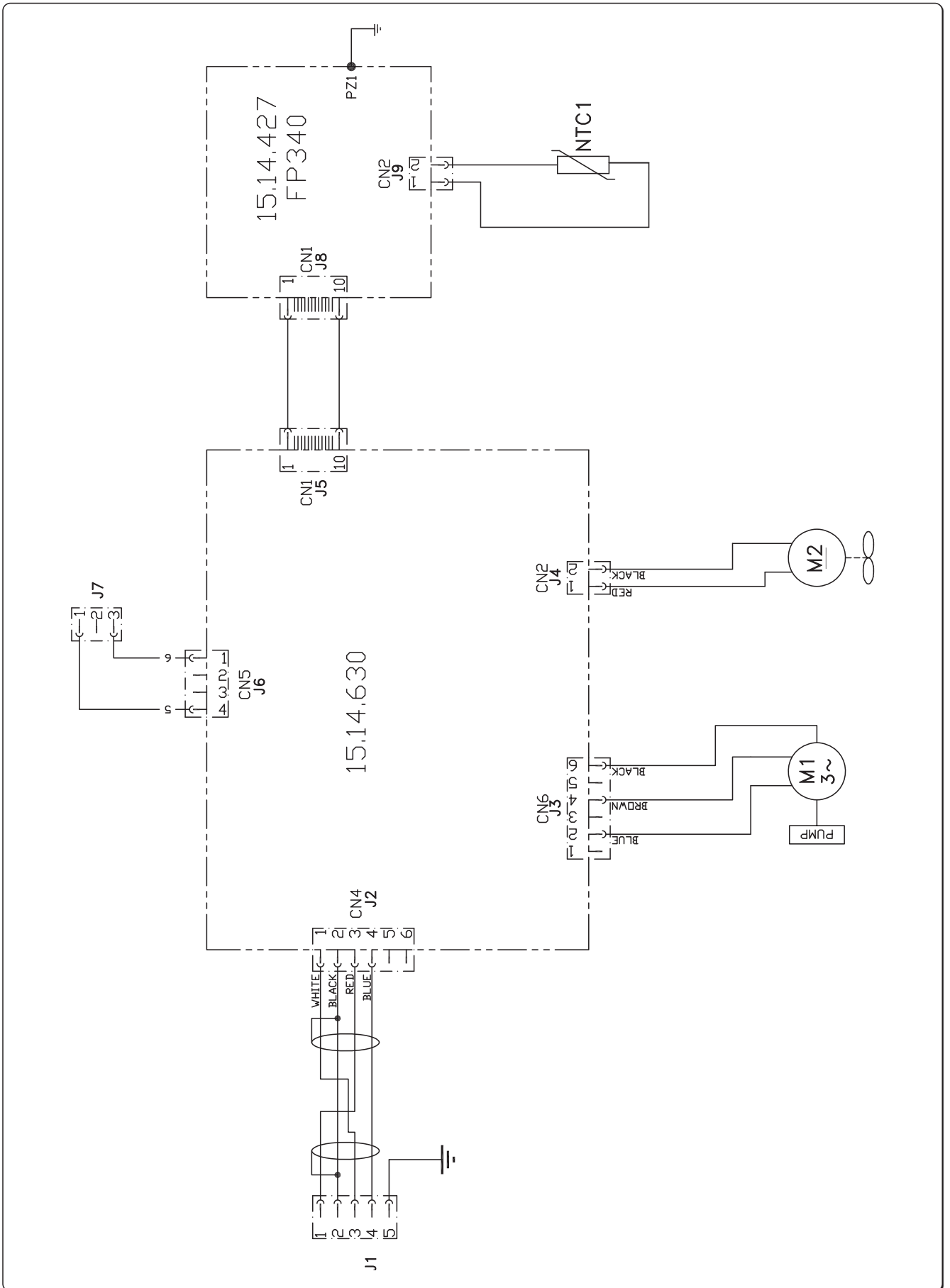

11. CONNETTORI, CONNECTORS, VERBINDER, CONNECTEURS, CONECTORES, CONECTORES, VERBINDINGEN, KONTAKTDON, KONNEKTORER, SKJØTEMUNNSTYKKER, LIITTIMET, ΣΥΝΔΕΤΗΡΕΣ

WU 2000 (71.03.076)

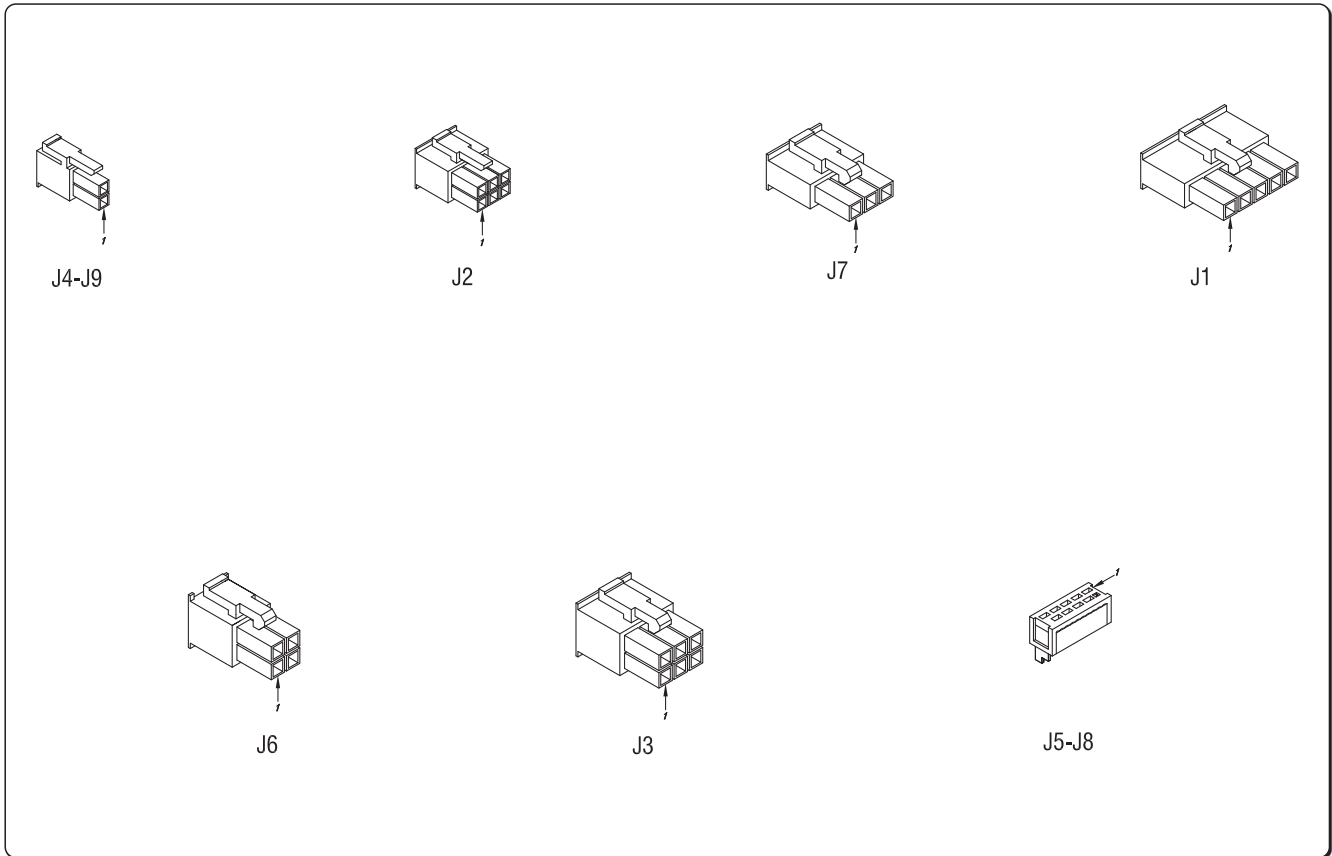

12. LISTA RICAMBI, SPARE PARTS LIST, ERSATZTEILVERZEICHNIS, LISTE DE PIÈCES DÉTACHÉES, LISTA DE REPUESTOS, LISTA DE PEÇAS DE REPOSIÇÃO, LIJST VAN RESERVE ONDERDELEN, RESERVDIELSLISTA, RESERVEDELSLISTE, LISTE OVER RESERVEDELER, VARAOSALUETTELO, ΚΑΤΑΛΟΓΟΣ

WU 2000 (71.03.076)

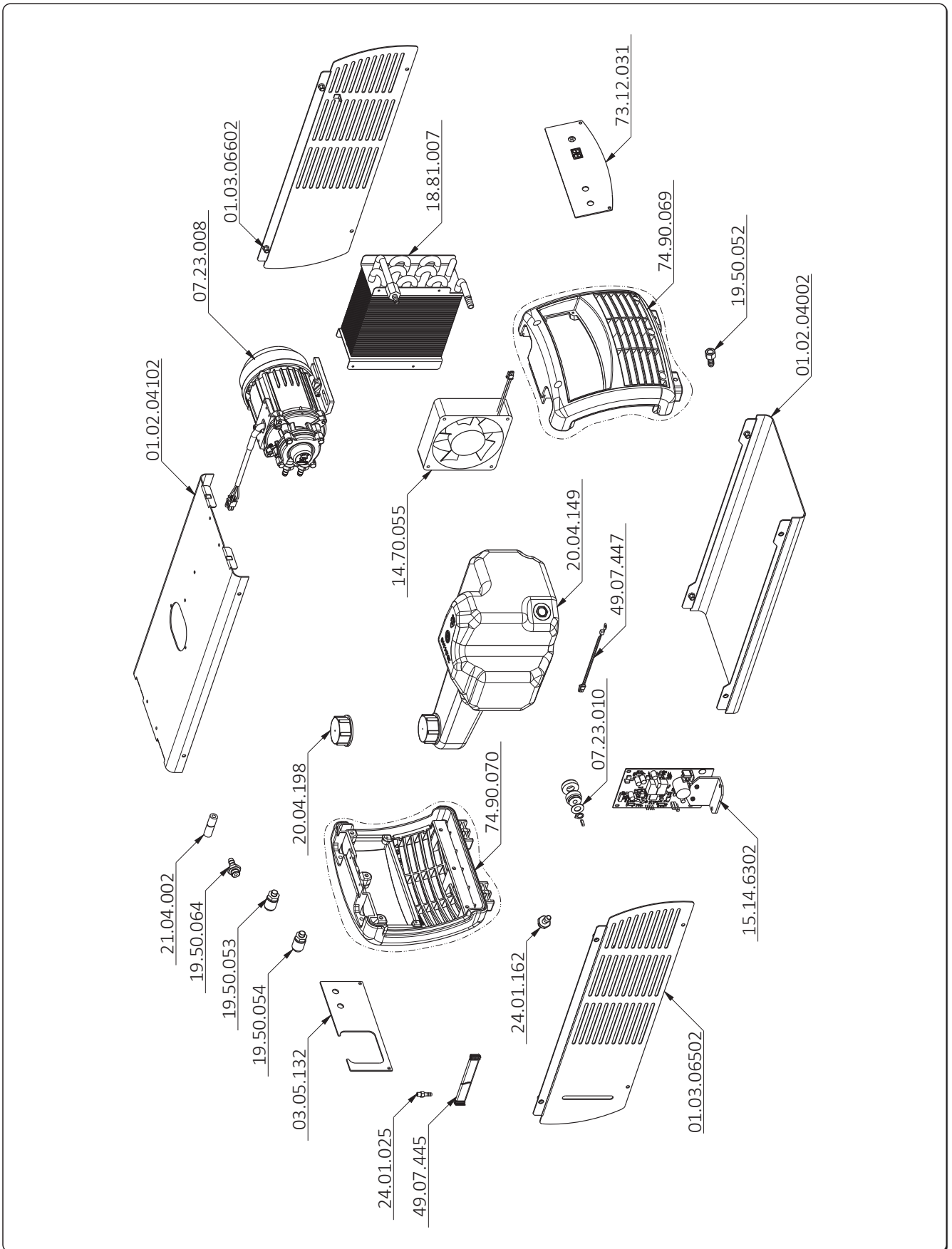

CODE	ITALIANO	ENGLISH	DEUTSCH	FRANÇAIS	ESPAÑOL
01.02.04002	Cofano inferiore	Metal cover lower	Unteres Gehäuse	Carter inférieur	Chapa inferior
01.02.04102	Cofano superiore	Metal cover upper	Oberes Gehäuse	Carter supérieur	Chapa superior
01.03.06502	Pannello laterale DX	Side panel - RIGHT	Seitenpaneel - RE	Panneau latéral droit	Panel lateral derecho
01.03.06602	Pannello laterale SX	Side panel - LEFT	Seitenpaneel - LI	Panneau latéral gauche	Panel lateral izquierdo
03.05.132	Targa posteriore	Rear nameplate	Hinterschild	Plaque arrière	Placa posterior
07.23.008	Pompa idraulica rotativa	Peripheral electrical pump	Kreiselpumpe	Pompe hydraulique rotative	Bomba hidráulica rotativa
07.23.010	Tenuta meccanica pompa	Waterproof	Mechanische pumpendichtung	Garniture mécanique pompe	Cierre mecánico bomba
14.70.055	Ventilatore	Fan	Ventilator	Ventilateur	Ventilador
15.14.6302	Scheda elettronica	P.C. Board	Elektronische platine	Platine électronique	Tarjeta electrónica
18.81.007	Scambiatore di calore	Heat exchanger	Wärmetauscher	Echangeur de chaleur	Intercambiador de calor
18.91.008	Liquido refrigerante CL10 (tanica 10kg)	Coolant CL10 (10kg)	Kühlflüssigkeit CL10 (tank 10kg)	Liquide de refroidissement CL10 (10kg)	Coolant CL10 (10kg)
19.50.052	Portagomma	Hose holder	Schlauchhalter	Porte tuyau	Boquilla manguera
19.50.053	Innesto rapido acqua 1/8" blu	Quick connector h2o (blue) - 1/8"	Wasserschnellanschluss 1/8" blau	Raccord rapide eau 1/8" bleu	Conexión rápida agua 1/8" azul
19.50.054	Innesto rapido acqua 1/8" rosso	Quick connector h2o (red) - 1/8"	Wasserschnellanschluss 1/8" rot	Raccord rapide eau 1/8" rouge	Conexión rápida agua 1/8" rojo
19.50.064	Portagomma	Hose holder	Schlauchhalter	Porte tuyau	Boquilla manguera
20.04.149	Serbatoio	Tank	Tank	Réservoir	Depósito
20.04.198	Tappo	Cap	Stopfen	Bouchon	Tapón
21.04.002	Tube PVC retinato 6x12	Braided PVC hose - 6x12	Pvc-gewebeschlauch 6x12	Tuyau PVC avec gaine de protection 6x12	Manguera PVC con malla 6x12
24.01.025	Portagomma	Hose holder	Schlauchhalter	Porte tuyau	Boquilla manguera
24.01.162	Portagomma 1/4"	Hose holder 1/4"	Schlauchhalter 1/4"	Porte tuyau 1/4"	Boquilla manguera 1/4"
49.07.445	Flat collegamento	Connection flat	Verbindung	Connection	Acoplamiento
49.07.447	Sensore termico	Thermal sensor	Wärmefühler	Capteur thermique	Sensor térmico
73.12.031	Kit scheda elettronica	P.C. Board kit	Elektronische karte kit	Kit platine	Kit tarjeta electrónica
74.90.069	Kit plastiche frontali	Front panel (plastic) - Spare kit	Kit kunststoffteile vorne	Kit parties en plastique frontales	Kit partes plásticas frente
74.90.070	Kit plastiche posteriori	Rear panel (plastic) - Spare kit	Kit hintere kunststoffteile	Kit parties en plastique arrière	Kit partes plásticas posteriores
91.09.048	Manuale istruzioni: WU 2000 [IT,EN,DE,FR,ES,PT,NL,SV,DA,NO,FI,EL]	Instruction manual: WU 2000 [IT,EN,DE,FR,ES,PT,NL,SV,DA,NO,FI,EL]	Bedienungsanweisungen: WU 2000 [IT,EN,DE,FR,ES,PT,NL,SV,DA,NO,FI,EL]	Manuel d'instructions: WU 2000 [IT,EN,DE,FR,ES,PT,NL,SV,DA,NO,FI,EL]	Manual instrucciones: WU 2000 [IT,EN,DE,FR,ES,PT,NL,SV,DA,NO,FI,EL]
91.09.056	Manuale istruzioni: WU 2000 [CS,P,LI,RU,TR,RO,BG,SK,ET,LV,LT,HU,SJ]	Instruction manual: WU 2000 [CS,P,LI,RU,TR,RO,BG,SK,ET,LV,LT,HU,SJ]	Bedienungsanweisungen: WU 2000 [CS,PL,RU,TR,RO,BG,SK,ET,LV,LT,HU,SJ]	Manuel d'instructions: WU 2000 [CS,PL,RU,TR,RO,BG,SK,ET,LV,LT,HU,SJ]	Manual instrucciones: WU 2000 [CS,PL,RU,TR,RO,BG,SK,ET,LV,LT,HU,SJ]

