



ROLLER SYSTEM FOR CROSSINGS WITH MOVABLE POINT

Low-maintenance roller system for crossings with movable point “HBS-Roller”

Description

The roller for the point of the crossing, HBS-Roller, is a roller system developed for turnout crossings with movable point. The HBS-Roller lifts the movable point from the slide plates by up to 2 mm during the setting movement and places it back on the slide plates when the point reaches its final position. Thus extensive lubrication and cleaning of the slide plates becomes obsolete.

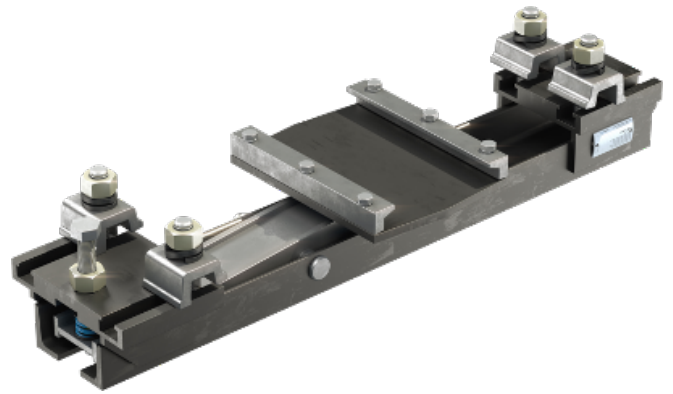

System advantages

The system has the advantage of being easily retrofittable on crossings even during operation because the components are supplied pre-assembled to the site or the components have to be clamped onto the supporting structure and the point of the crossing only. Generally, no machining of the crossing is required.

The use of HBS-Roller in the crossing area guarantees the following functions:

- » Makes maintenance (lubrication) of the slide plates in the crossing area obsolete (rolling instead of sliding friction)
- » During the passage of the train, the point of the crossing rests firmly on the slide chairs

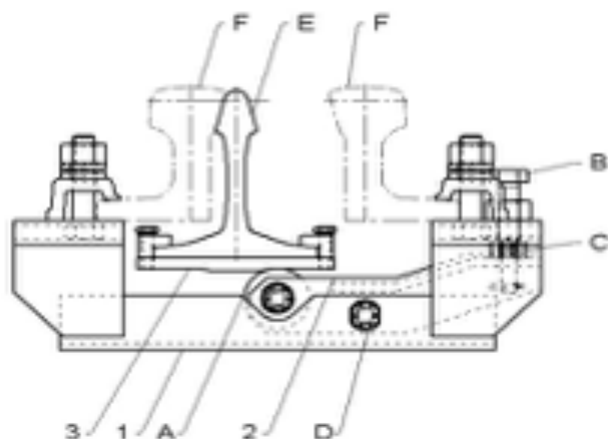

The HBS-Roller consists in principle of 3 main components:

1. Girder
2. Lever
3. Sliding strip

In addition fastening elements:

- A. Roller
- B. Adjusting bolt
- C. Spring system
- D. Lever bearing
- E. Point of the crossing
- F. Wing rails

Detailed description

Mounting and functioning: A sliding strip is clamped onto the point of the crossing or on the point rail or splice rail using a connector block. This sliding strip has an elevation by which a stroke corresponding to the mounting position and a defined lifting of the point of the crossing is achieved. So the point is lifted during the setting movement by the roller mounted on the lever and rolls on it to its final position.

The girder with pre-mounted lever is clamped on the wing rails (fig. 1) or on the baseplate assembly of the crossing (fig. 2) depending on site conditions. These fastening elements are designed in such a way that horizontal displacement and adjustment of the central position of the point of the crossing relative to the baseplate assembly can be done and that the girder can be mounted on different widths of baseplate assemblies and distances of wing rails.

The height of the roller can be adapted to the sliding strip by means of an adjusting bolt installed in the girder. A spring system deviates the arising forces and impacts.

Technical description

- » Retrofittable roller system for movable points
- » Materials:
 - » Rollers: Synthetic material
 - » Girder and sliding strip: Structural steel