



ROLLER SYSTEM INTEGRATED INTO THE PLATE

“PIROLL” for switch assemblies with rail switches

Description

PIROLL (Plate Integrated Rolling System) is a voestalpine Railway Systems developed roller system for switch assemblies of Vignole rails, which eliminates the need for high-effort cleaning and lubrication of the slide plates in the area the switch assembly.

The PIROLL system thus completely meets customer needs and demands for less maintenance and improved environmental protection.

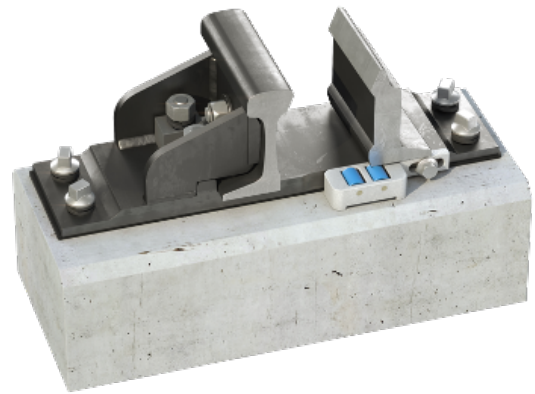

System advantages

- » Elimination of maintenance (cleaning and lubrication of the slide plates)
- » Reduction of switching forces
- » No components in the sleeper compartment (roller cassettes laterally mounted to the plates)
- » No obstruction during sleeper tamping work
- » Can be pre-assembled in the switch assembly
- » Easily replace individual rollers or the entire roller cassette
- » No inlet grooves in the switch base due to the use of plastic rollers

ROLLER SYSTEM INTEGRATED INTO THE PLATE

Type overview

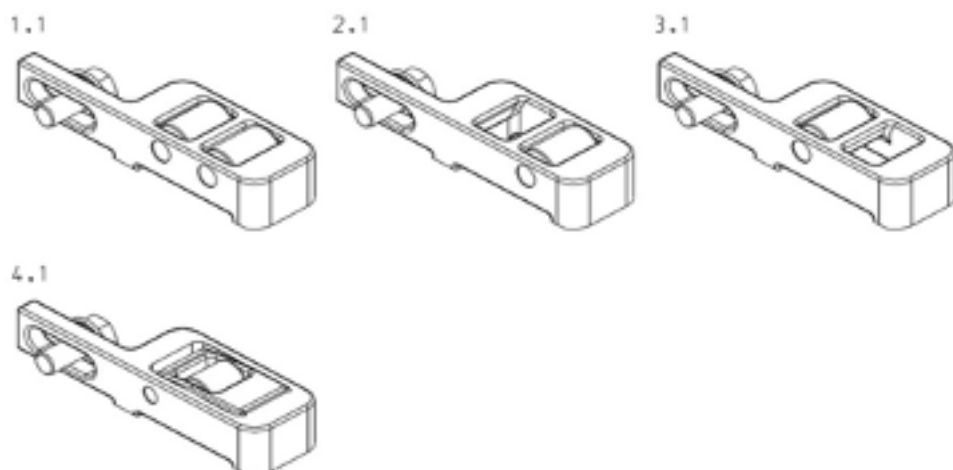

Description

The roller cassettes are laterally mounted to the slide plates.

The standard roller cassettes are designed so that the switch is raised slightly by 1 mm up to max. 2.5 mm from the slide plates during setting motion. The switch rolls on the rollers during the movement. The switch driven on—that is on the stock rail is always on the slideplates and not on the rollers. The applied switch that is not driven on is on the rollers.

To support the setting movement, roller cassettes of the type Piroll-S (spring) can be arranged in the area of the switch root, which raise the spring-loaded switch by a maximum of 1 mm from the slide chairs.

Technical description

- » Roller cassettes with plastic rollers
- » The rollers are mounted with plain bearings
- » Pre-assembly possible

The roller cassettes are arranged adjusted to the switch assembly type.

The uniform arrangement of the PIROLL roller-cassettes across the entire switch-length to the clamping point causes:

- » A uniform raising of the switches during the switching process
- » Only a slight bending of the switches in the vertical direction
- » A uniform movement of the switches during the switching process

» Material

- » Cassette: GJS ductile iron
- » Roller: modified polyamide